

**Proceedings of AWADE-2018**  
the 3<sup>rd</sup> Seminar and the 1<sup>st</sup> Student Design Competition



Nanjing, China, 2018, October 14-17

Nanjing University of Aeronautics and Astronautics



## **Proceedings of AWADE-2018** the 3<sup>rd</sup> Seminar and the 1<sup>st</sup> Student Design Competition

Three years have passed since the organization of the Asian Workshop on Aircraft Design Education (AWADE). This form of activities in the field of aircraft engineering in education involves various formats: seminars and student competitions, the implementation of joint projects, the preparation of educational materials, etc. The main goal of the AWADE is to improve the process of training students in the field of aircraft design from both scientific and methodical points of view. AWADE-2018 was held in Nanjing University of Aeronautics and Astronautics (NUAA) on October 14-17. AWADE-2018 included work in two directions: a seminar and an individual student design competition and was dedicated to the 60<sup>th</sup> anniversary of the flight of first Chinese JJ-1 jet.

Proceedings materials include 26 reports of the 3rd AWADE seminar as well as information about holding of the individual student design competition, which was attended by students of three universities.

Edited and decorated by Professor Anatoly Kretov

Printed at Nanjing University of Aeronautics and Astronautics

© Nanjing University of Aeronautics and Astronautics

© The authors of the papers AWADE-2018

## TABLE OF CONTENTS

### AWADE-2018 Seminar\*

<b>Brief History of Asian- and European WADE and program of AWADE 2018.....</b>	<b>6</b>
<i>Organizing Committee of AWADE</i>	
Nanjing University of Aeronautics and Astronautics (China)	
<b>Aircraft Design for Reduced Carbon Emissions.....</b>	<b>11</b>
<i>Anthony P. Hays</i>	
California State University Long Beach, California (USA)	
<b>Work Experience at the NUAA Summer Lecture Program.....</b>	<b>20</b>
<i>Liia Makarova</i>	
Kazan National Research Technical University named after A. N. Tupolev – KAI (Russia) and Nanjing University of Aeronautics and Astronautics, College of Aerospace Engineering (China)	
<b>Flight on a Passenger Plane as the Process to Study the Aviation Basics .....</b>	<b>25</b>
<i>Clifton Read and Anatolii Kretov</i>	
Executive Wisdom Consulting Group, Brisbane (Australia) and Nanjing University of Aeronautics and Astronautics, College of Aerospace Engineering (China)	
<b>Project-based Aircraft Design Education at the Hong Kong Polytechnic University.....</b>	<b>33</b>
<i>Wen Chih-Yung and Sun Jingxuan</i>	
The Hong Kong Polytechnic University, Department of Mechanical Engineering, Department of Mechanical and Aerospace Engineering, Hong Kong (China)	
<b>Aircraft Using Ground Effect: History, Features, Efficiency Estimation and Prospect of Development.....</b>	<b>42</b>
<i>Victor Morozov and Enoch Ahiagbedey</i>	
“Aerorick” Enterprise, Ltd, Nizhny Novgorod (Russia), and Nanjing University of Aeronautics and Astronautics, College of Aerospace Engineering (China)	
<b>Optimization of Structure by Stiffness Criteria .....</b>	<b>52</b>
<i>Pavel Shataev and Samuel E. Nana Agyeman</i>	
Kazan National Research Technical University named after A. N. Tupolev – KAI (Russia) and Nanjing University of Aeronautics and Astronautics, College of Aerospace	
<b>About Curriculums for the Foreign Graduate Students Majoring in "Aircraft Design" of NUAA .....</b>	<b>62</b>
<i>ZhiJin Wang and Anatolii Kretov</i>	
Nanjing University of Aeronautics and Astronautics, College of Aerospace Engineering (China)	

\* – the papers follow in that sequence in which they were presented at the seminar and in that view in which they were sent by their authors without any additional edit

## TABLE OF CONTENTS

<b>Structure and Properties of Dragonfly Wings: Composite Structure of Fibrous Material Supplemented by Resilin</b> .....	69
<i>Esther Appel, Hamed Rajabi and Stanislav Gorb</i> Department of Functional Morphology and Biomechanics, Zoological Institute of the University of Kiel (Germany)	
<b>Design and Manufacturing of Aircraft Hatch from Composite Materials Using the Technology of Tailored Fiber Placement</b> .....	72
<i>Daria Bezzametnova, Alexandra Kuzmina, Fariddun Boboev</i> Kazan National Research Technical University named after A. N. Tupolev – KAI (Russia)	
<b>Design and Manufacture Primary Load Carrying Parts of Aircraft from Composite Materials Using Radial Braiding</b> .....	79
<i>Valentin Khaliulin, Alena Khudova, Ramazon Ysmonov</i> Kazan National Research Technical University named after A. N. Tupolev – KAI (Russia)	
<b>Investigation of Constructive-Techlogical Solution of Multi-Walled Construction</b> .....	85
<i>Venera Sakhbutdinova, Elena Petrunina, Ramazon Usmonov</i> Kazan National Research Technical University named after A. N. Tupolev – KAI (Russia)	
<b>The Major Content of the Curricula on the Airplane Designing Direction in National Aerospace University KhAI</b> .....	89
<i>Dmytro V. Tiniakov</i> Nanjing University of Aeronautics and Astronautics, College of Civil Aviation (China)	
<b>Review of Problems of Ensuring Reliability of Fuel Systems of Modern Supersonic Business Jet Airplanes</b> .....	94
<i>Anna Nechyporenko, Su Yan, Dmytro V. Tiniakov</i> Nanjing University of Aeronautics and Astronautics, College of Civil Aviation (China)	
<b>Features of the Use Titanium Alloys in the Construction of Aerospace Setting</b> .....	100
<i>Oleksandr Moliar, Yao Zhengjun, Zhang Shasha, Liu Zili, Miao Qiang, Zhang Pingze</i> Nanjing University of Aeronautics and Astronautics, College of Material Science and Technology Key Laboratory of Materials Preparation and Protection for Harsh Environment (China)	
<b>Reusable Space Systems: from the Space Shuttle to the Saved First Stages</b> .....	108
<i>Anatolii Kretov and Temur Usmonov</i> Nanjing University of Aeronautics and Astronautics, College of Aerospace Engineering (China) and Department of Aircraft design (Uzbekistan)	
<b>Using Parachute System for Salvation of the First Stages of Launches Vehicles</b> .....	117
<i>V.Chizhukhin, Yu.Mekhonochin, S.Zhjurov, Yu.Gvozdev, V.Yushkov, A.Lykov</i> Joint Stock Company “Atmosphere”, Dolgoprudny, Moscow region (Russia)	
<b>Initial Aircraft Sizing – a Critique</b> .....	125
<i>Anthony P. Hays</i> California State University Long Beach, California (USA)	

## TABLE OF CONTENTS

<b>Piezoelectric Motors for Micro Air Vehicle</b> .....	135
<i>Piotr Vasiljev, Dalius Mazeika, Sergejus Borodinas, Jianmin Qiu</i> Nanjing University of Aeronautics and Astronautics (China), and Lithuanian University of Educational Sciences, and Vilnius Gediminas Technical University, Vilnius (Lithuania)	
<b>Online Learning in Aeronautical Engineering Education at Some American Universities</b> .....	143
<i>Stephane Tambwe , and Oleksiy Chernykh, and Dmytro Tiniakov</i> Nanjing University of Aeronautics and Astronautics, College of Civil Aviation (China)	
<b>Aircraft Features with Amphibious Chassis</b> .....	151
<i>Victor Morozov and Gabriel Andriamanantena</i> “Aerorick” Enterprise, Ltd, Nizhny Novgorod (Russia), and Nanjing University of Aeronautics and Astronautics, College of Aerospace Engineering (China)	
<b>Teaching of Russian Language in the Framework of Sandwich Project Between National Aerospace University “KhAI” and NUAA</b> .....	161
<i>Olena Litvinova, Alina Matskevich, Natalya Sytnyk, Dmytro Toporets</i> National Aerospace University KhAI, Kharkiv (Ukraine)	
<b>Civil Airplane Rational Designing on the Base of Aerodynamic Requirements</b> .....	166
<i>Clifton Read, Dmytro V. Tiniakov</i> Executive Wisdom Consulting Group, Brisbane (Australia), Nanjing University of Aeronautics and Astronautics, College of Civil Aviation, Nanjing (China)	
<b>Virtual Reality as an Ongoing Challenge for Aviation Industry</b> .....	173
<i>Fares Elsherbiny and Oleksiy Chernykh</i> University of Politehnica of Bucharest (Romania), Nanjing University of Aeronautics and Astronautics, College of Civil Aviation, Nanjing (China)	
<b>At the helm of Aeronautics</b> .....	180
<i>Diane Uyoga</i> Moi University, Eldoret (Kenya)	
<b>Overall Design and Energy Estimate of HALE Solar-Powered UAV</b> .....	185
<i>Mingjie Zhong, S.V.Mrykin</i> Beihang University, School of Aeronautic Science and Engineering, Beijing (China), Samara State University, Department of Aircraft Engineering, Samara (Russia)	
<b>Questions to the Students’ Individual Competition on Aircraft Design</b> .....	193
<b>AWADE Participation in the Seminar Work of READ-EWADE-2018</b> .....	196
<b>A Brief Report on the Results AWADE-2018</b> .....	201
<b>Conclusions</b> .....	203
Appendix: <b>Photo Gallery of AWADE-2018: Seminar with Student Design Competition</b> .....	204-222

## BRIEF ASIAN- WADE AND EUROPEAN-WADE HISTORY AND PROGRAM OF AWADE 2018

### AWADE Organizing Committee

Nanjing University of Astronautics and Aeronautics, College of Aerospace Engineering,  
29 Yudao St., Nanjing 210016, P R. China  
e-mail:[kretov-ac@nuaa.edu.cn](mailto:kretov-ac@nuaa.edu.cn)

**Key words:** Asian Workshop, Seminar, Student Design Competition, Schedule.

**Abstract.** *The history of creation of the Asian Workshop on Aircraft Design Education, tasks which are put before organizers of AWADE is considered. The program of AWADE-2018 is being considered that is carrying out according to the new formula including simultaneous carrying out of a seminar and student design competition. AWADE-2018 is being held in Nanjing University of Aeronautics and Astronautics on October 14-17.*

### 1. INTRODUCTION

The aerospace industry plays a large economic and strategic role in every highly developed country. To be sure that this sector will give effective results we need to have at least three successful components: education, science and production. All these components interconnected, but at the 1-st place consistently goes education, providing for all three components the employees. It means in every case the education must be primary.

Important role in the preparing of aviation professionals playing the discipline “Aircraft design”. How to make this discipline more effective for studying, how to provide a better understanding it of students, how to direct its ability to implement student fresh ideas and dreams. These questions have always existed and always remain relevant.

In November 2015 the participants of seminar of Institute of Aircraft Design Technology of Nanjing University of Aeronautics and Astronautics decided to organize on Asian continent the regular Workshop on Aircraft Design Education. It have to be function similar to the European Workshop on Aircraft Design Education (EWADE). It was called Asian Workshop on Aircraft Design Education (AWADE). This workshop should be with the assistance of experts in the field of the Aircraft Design from all countries and EWADE as well.

#### **The brief history of EWADE [1]:**

- 1st Workshop: 1994 Madrid (Spain)
- 2nd Workshop: 1996 Berlin (Germany)
- 3th Workshop: 1998 Bristol (England)
- 4th Workshop: 2000 Turin (Italy)
- 5th Workshop: 2002 Linköping (Sweden)
- 6th Workshop: 2004 Brno (CzechRepublic)
- 7th Workshop: 2005 Toulouse (France)
- 8th Workshop: 2007 Samara (Russia)

## AWADE Organizing Committee

9th Workshop: 2009 Sevilla (Spain)

10th Workshop: 2011 Naples (Italy)

11th Workshop: 2013 Linköping (Sweden)

12th Workshop: 2015 Delft (Netherlands)

13th Workshop: 2017 in Bucharest (Rumania)

14th Workshop: In 2018, the READ (Research and Education in Aircraft Design) and EWADE will be connected together and the workshop will be hosted by Institute of Engineering, Brno University of Technology in Brno (Czech Republic) on November, 7-9.

### History AWADE

History AWADE still quite short [2]:

AWADE 2016. The 1st Seminar October 8-11;

AWADE 2017. The 2nd Seminar October 17-20;

AWADE 2018. The 3rd Seminar and Student Design Competition October 14-17.

This AWADE-2018 is dedicated to the 60th Anniversary of the flight of the first Chinese jet JJ-1 (Fig.1).



Fig.1. Symbols of the AWADE 2018

Briefly about the anniversary event. The first jet aircraft of Chinese design, which rose into the air in 1958, was the training JJ-1. Its design began in October 1956 in the design Bureau at the aircraft factory in Shenyang, formed a month earlier. The aircraft had a straight wing, two side air intakes and tandem crew location under a single lamp. The RD-500 engine was located in the Central part of the fuselage. "Test wing" of the new machine took place on 26 July 1958. The Results of flight tests confirmed the calculated machine performance (it should be noted, are quite high for its time). However, the abandonment of the three-stage cycle of training of pilots of the Chinese air force (piston aircraft initial training – jet main cycle-combat training aircraft – jet of depth training ) and the transition to a two-stage cycle (piston aircraft – jet of depth training) led to the cessation of work on the JJ-1.

## 2. CONTENT OF AWADE-2018

A new formula is used for the holding of the AWADE:

*Seminar + Student Design Competition*

And again, with the widespread use of the Skype conference format.

## AWADE Organizing Committee

### 2.1. Seminar

15<sup>th</sup> October (Mon), morning

**Session 1** Session chair: *Prof. Anatolii Kretov*

Num-ber	Time (Beij.)	Author(s) and Topic
	08:30 – 09:00	<b>Registration of participants</b>
1	09:00 – 09:15	<i>Prof. Pingi Xia</i> (Dean of Aerospace Engineering College, NUAA) ( <i>Speaker</i> ) & <i>Prof. Zhang Zhuo</i> (Director of International Office, NUAA) <b>WELCOME SPEECH TO ASIAN WORKSHOP AWADE-2018</b>
2	09:15 – 09:30	<i>Prof. Anatoly Kretov</i> (NUAA) Brief Asian- and European WADE and program of AWADE 2018
3	09:30 – 11:20	<i>Prof. Anthony P. Hays</i> (California State University Long Beach, USA) <b>Plenary presentation: Aircraft Design for Reduced Carbon Emissions</b>
4	11:20 – 11:40	<i>Dr. Liia Makarova</i> (NUAA, Kazan NRTU, Russia) <b>Work Experience at the NUAA Summer School</b>
5	11:40 – 12:00	<i>Skype-report from Australia: Clifton Read</i> (Executive Wisdom Consulting Group, Brisbane, Australia) & <i>Prof. A. Kretov</i> (NUAA) <b>Flight on a passenger plane as the process to study the aviation basics</b>

15<sup>th</sup> October (Mon), afternoon

**Session 2** Session chair: *Anthony P. Hays*

6	14:00– 14:25	<i>Skype-report from Hong Kong: Wen Chih-Yung, Sun Jingxuan</i> (Hong Kong Polytechnic University) <b>Project-based Aircraft Design Education at the Hong Kong Polytechnic University</b>
7	14:25– 14:50	<i>Dr. Victor Morozov</i> (“Aerorick” Enterprise, Ltd, Nizhny Novgorod, Russia) & <i>Enoch Ahiagbedey</i> , (NUAA)( <i>Speak.</i> ) <b>Aircraft Using Ground Effect: History, Features, Efficiency Estimation and Prospect of Development</b>
8	14:50– 15:10	<i>Pavel Shataev</i> (Kazan National Research Technical University, Russia) & <i>Samuel E. Nana Agyeman</i> , (NUAA)( <i>Speak.</i> ) <b>Optimization of Structure by Stiffness Criteria</b>
9	15:35– 15:50	<i>Prof. Z. Wang &amp; Prof. A. Kretov</i> (NUAA) ( <i>Speaker</i> ) <b>About the Curriculum for Foreign NUAA Students-masters on Aircraft Engineering</b>
10	15:50– 16:10	<i>Skype-reports from Germany: Esther Appel, Hamed Rajabi and Stanislav Gorb.</i> (Department of Functional Morphology and Biomechanics, Zoological Institute of the University of Kiel, Germany). <b>Structure and Properties of Dragonfly Wings: Composite Structure of Fibrous Material Supplemented by Resilin</b>
11	16:10– 16:30	<i>Student’s Skype-presentation from Russia: A.V. Kuzmina, F.N. Boboev, D. N. Bezzametnova.</i> (National Research Technical University – KAI, Kazan, Russia) <b>Design and Manufacture of Hatches of Aircrafts from Composite Materials with the Use of Directional Laying of the Fiber (TFP)</b>
12	16:30– 16:50	<i>Skype-report from Russia: V.I. Khaliulin, R.S. Usmonov and A.A. Khudova.</i> (Kazan National Research Technical University, Russia) <b>Design and Manufacture of Power Components of Aircraft Ade of Composites with the Use of Radial Braiding</b>
13	16:50– 17:10	<i>Skype-report from Russia: V.R. Sakhbutdinova, R.S. Usmonov and E.S. Petrunina.</i> (Kazan National Research Technical University, Russia) <b>The Process of Manufacturing a Multi-wall Panel of Aircraft From Composites</b>
	17:10 – 18:10	The SDC work group: Consideration of tasks for the SDC

16<sup>th</sup> October (Tue), morning

**Session 3** Session chair: *Dr. Oleksiy Chernykh*

14	09:00 –09:20	<i>Dr. Dmytro V. Tiniakov</i> (NUAA) <b>Major content of Curricula on the direction Aircraft Design at National Aerospace University KhAI</b>
15	09:20 – 09:40	<i>Anna V. Nechiporenko, Dr. Su Yan, Dr. Dmytro V. Tiniakov</i> , (NUAA) <b>The Main Problems of the Supersonic Aircraft Fuel System Designing for the Transport Category, Taking into Account Its Certain Reliability Providing</b>



## AWADE Organizing Committee

16	09:40 – 10:00	<i>Dr.Oleksander Molier</i> (NUAA, Antonov State Company, Kyiv, Ukraine) <b>Features of Titanium as a Structural Material for Aerospace Engineering</b>
17	10:25 – 10:50	<i>Prof.A.Kretov</i> (NUAA), <i>Temur Usmonov (Speaker)</i> (NUAA, Department of Aircraft design, Uzbekistan) <b>Reusable Space Systems: from the Space Shuttle to the Salvation of the First Stages</b>
18	10:50 – 11:10	<i>V.Chizhukhin, Yu.Mekhonochin, S.Zhjurov, Yu.Gvozdev, V.Yushkov, A.Lykov</i> (Joint Stock Company “Atmosphere”, Dolgoprudny, Russia) <b>Using Parachute System for Salvation of the First Stages of Launches Vehicles</b>
19	11:10– 11:40	<i>Anthony P. Hays</i> (California State University Long Beach, USA) <b>Initial Aircraft Sizing – a Critique</b>
20	11:40– 12:00	<i>Jianmin Qiu</i> (NUAA), <i>prof.Dalius Mazeika, prof.Piotr Vasiljev, prof.Sergejus Borodinas.</i> (Vilnius Gediminas Technical University, Vilnius, Lithuania) <b>Piezoelectric Motors for Micro Air Vehicle</b>

16<sup>th</sup> October (Tue), afternoon

### Session 4

Session Chair: *Prof.A. Kretov*

21	14:10–14:30	<i>Stephane Tambwe (Speaker)</i> , and <i>Oleksiy Chernykh, and Dmytro Tiniakov</i> , (NUAA) <b>Online Learning in Aeronautical Engineering Education</b>
22	14:30–14:55	<i>Dr.Victor Morozov</i> (“Aerorick”, Nizhny Novgorod, Russia) & <i>Gabriel Tnajona Yves</i> , (NUAA) (SP) <b>Aircraft Features with Amphibious Chassis (with Movie Demonstration)</b>
23	14:55–15:15	<i>Skype- report from Ukraine: Olena Litvinova, Alina Matskevich, Natalya Sytnyk, Dmytro Toporets</i> (National Aerospace University KhAI, Ukraine) <b>Teaching of Russian Language in the Framework of Sandwich Project Between National Aerospace University “KhAI” and NUAA</b>
24	15:15–15:35	<i>Skype- report from Australia Dr.Dmytro V. Tiniakov</i> , (NUAA), <i>Clifton Read.</i> (Executive Wisdom Consulting Group, Brisbane, Australia) <b>Civil Airplane Rational Designing on the Base of Aerodynamic Requirements</b>
25	15:35–16:00	<i>Skype- report from Romanian Fares Ibrahim ELSHERBINY</i> (University Politechnica of Bucharest, Romania), <i>Oleksiy Chernykh</i> (NUAA) <b>Application of Augmented Virtual Reality Devices in Aviation Training</b>
26	16:00–16:20	<i>Skype- report from Keny Prof. Diane Uyoga</i> (Moi University, Kesses, Kenya) <b>At the helm of Aeronautics</b>

### Poster Session

27	All time	<i>Zhong Mingjie, prof. Mrykin S.V., prof. Liu Li</i> (Beihang university, Beijing and Samara State University, Samara, Russia) <b>Designing High-altitude Unmanned Aircraft</b>
----	----------	---

## 2.2. Student Design Competition (individual competition)

SDC is being held in the modes of direct participation (NUAA) and Skype-conference (KhAI, Ukraine; KAI, Russia)

SDC Chairman: *Dr.Dmytro Tiniakov*

16<sup>th</sup> October (Tue), afternoon

- [14:15 – 14:30] setting questions to SDC participants;
- [14:30 – 16:30] preparation of answers by SDC participants;
- [16:30 – 16:45] submission of answers to competitive tasks;
- [16:45 – 17:30] consideration of the seminar participants of the SDC participants responses;
- [17:30 – 18:15] answers of SDC participants to Seminar participants;
- [18:15 – 19:00] evaluation by the seminar participants of student's responses.

## 3. CONCLUGIONS

26 works are presented at the Seminar. The number of authors is 49 from 13 universities and organizaciones from 13 countries (China, Russia, Ukraine, Germany, Romania, Lithuania,

## AWADE Organizing Committee

USA, Australia, Uzbekistan, Madagascar, Ghana, Congo and Kenya). During two working days October 15-16 4 sessions need to hold, where 25 reports will be to heard, including 11 in the format of Skype conference from other universities, one work will be presented in the form of a poster report.

After completion of the AWADE-2018 all these reports will be presented on the website of our workshop [2].

### REFERENCES

[1] <http://ewade2018.aircraftdesign.org>

[2] <http://aircraftdesign.nuaa.edu.cn/AWADE/index.html>

### Speaker



Anatolii Kretov  
Chairman of the Technical Committee AWADE-2018

## AIRCRAFT DESIGN FOR REDUCED CARBON EMISSIONS

**Anthony P. Hays**

California State University Long Beach  
1250 Bellflower Blvd, Long Beach 90840, USA

Email: [ahays@alum.mit.edu](mailto:ahays@alum.mit.edu) Web: [www.adac.aero](http://www.adac.aero)

**Key words:** Aircraft design, aircraft sizing, electric propulsion

**Abstract:** *For students, the conceptual design of an aircraft for reduced carbon emissions provides both opportunities for innovation, and challenges in estimating basic design parameters, especially empty weight, but also drag and power requirements. At present, liquid hydrogen (LH<sub>2</sub>) or electrical power are feasible alternatives to hydrocarbon fuel for many applications. An important requirement is that the energy storage system must have a high specific energy (energy per unit weight). LH<sub>2</sub> meets this requirement, but distribution and storage are expensive, rendering it economically impracticable. Batteries are an alternative, but the specific energy of a lithium battery is an order of magnitude less than that of carbon-based fuel. Electrically-driven impellers offer aircraft design flexibility that can partially offset the limitations of batteries' low specific energy, but for medium- and long-range aircraft, battery power alone is still infeasible. Long-range aircraft with significantly reduced carbon footprint will either need batteries with at least an order of magnitude increase in specific energy, or burn synthetically-produced hydrocarbon fuel made from atmospheric carbon dioxide and water, using a process similar to that of photosynthesis, or possibly nanoelectrofuel which uses electrically charged particles in a process similar to that of a fuel cell. All are in early stages of development. This paper examines propulsion options and possible design synergies.*

### 1. INTRODUCTION

In April 2016, 195 countries signed the Paris Agreement on climate change. These countries committed themselves to limit global temperature rise to 2<sup>0</sup> C above pre-industrial levels. The leading cause of climate change is the increase in levels of CO<sub>2</sub> in the atmosphere. This is in the class of green-house gases (GHGs), which have the characteristics of trapping heat in the atmosphere. GHG emissions due to air transportation represent less than 3% of worldwide GHG emissions, but it is also widely agreed that all GHG emitters must make a contribution to their reduction. At present, hydrogen or electricity are possible providers of energy, but the high cost of hydrogen production, transmission and storage renders it economically impracticable. When the user of energy is in a fixed location, power can usually be supplied economically from electricity generated by wind or solar cells. In North America, the cost of generating energy from these sources is now similar to the cost of energy generation from hydrocarbons [1], and the transition to non-hydrocarbon power generation is being delayed by politics rather than economics. For transportation, problems are a bit more difficult especially when the energy source must be carried with the vehicle. Electrical energy must currently be stored

in batteries, and as compared with hydrocarbon fuels, batteries have a much lower specific energy (energy per unit weight). For heavier-than-air aircraft, which includes nearly all air transportation, energy is required both to keep the aircraft in the air, and to propel it, so weight is critically important. For a fixed-wing aircraft flying at the minimum drag condition, exactly half the drag is due to lift, which is equal to aircraft weight in straight-and-level flight.

This revolution in air transportation propulsion offers opportunities for students in an aircraft conceptual design course to produce innovative concepts. But there are also challenges. It is difficult to estimate empty weight for an innovative concept, because there will be no database of similar concepts. Drag estimation may be a bit easier, unless the concept has some highly unusual external contours. If weight and drag are known, then the rate of energy consumption is relatively simple. Methods for sizing both hydrogen and electrical propulsion systems may be found in Gundlach [2], and for electrical propulsion in the forthcoming edition of Raymer [3]. This paper describes the wide variety of concepts currently under development, and this suggests that there are still many new opportunities for innovation.

## 2. HYDROGEN ENERGY

Liquid hydrogen is often used as rocket fuel, such as for the space shuttle main engines. Liquid hydrogen could be used as an aircraft fuel, either burning it in a turbofan with modified combustors, or using a fuel cell to generate electricity to turn a propeller using an electric motor. Several studies have been performed on the feasibility of hydrogen fuel for transport aircraft, including those by Lockheed and Airbus [4][5][6]. A Dimona single-seat aircraft modified by Boeing R&T Europe, powered in part by hydrogen using a fuel cell, was flown at the Paris Airshow in 2009. A similar power configuration by DLR/Hydrogenics called Pipistrel HY4 [7] first flew in September 2016. However the cost of making hydrogen (usually by reforming a liquid hydrocarbon), carbon dioxide capture, liquefaction, transportation, and storage, render hydrogen as economically infeasible for air transportation.

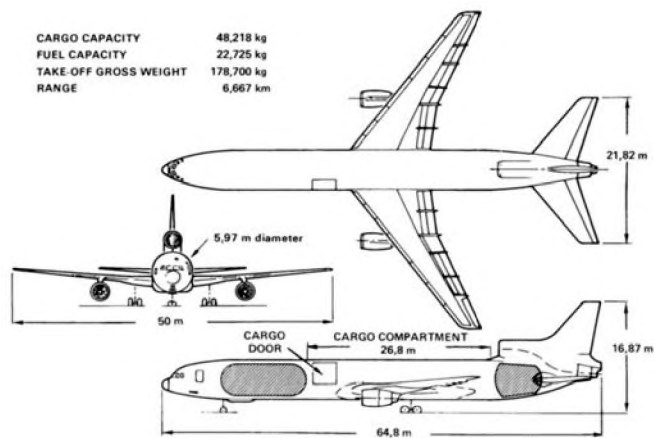

Source: Lockheed

Fig.1. LH<sub>2</sub>-powered Lockheed L1011-500

## 3. ELECTRICAL ENERGY

Using electric motors to power aircraft has become the preferred alternative to hydrogen. The primary limitation to widespread adoption is lack of batteries with a sufficiently high battery specific energy. Household Li-ion batteries have a specific energy of between 130 and 210 Wh/kg. Tesla cars use batteries holding about 250 Wh/kg, and Solar Impulse used batteries with specific energy of 260 Wh/kg. For an economically feasible short range electrically powered commercial aircraft, NASA estimates that a

specific energy of 400-500 Wh/kg will be required [8], and Airbus estimates a single-aisle transonic hybrid-electric aircraft will require batteries to have 800 Wh/kg[9]. So a significant improvement over Li-ion batteries will be required. Figure 2 summarizes the challenge. Another drawback of batteries is that the energy source is not discarded when the energy is used. For hydrocarbon or hydrogen fuel, the weight of the airplane is considerably less than at the start of the flight (by almost 40% for a long range flight), and drag (and hence energy consumption) is reduced commensurately.

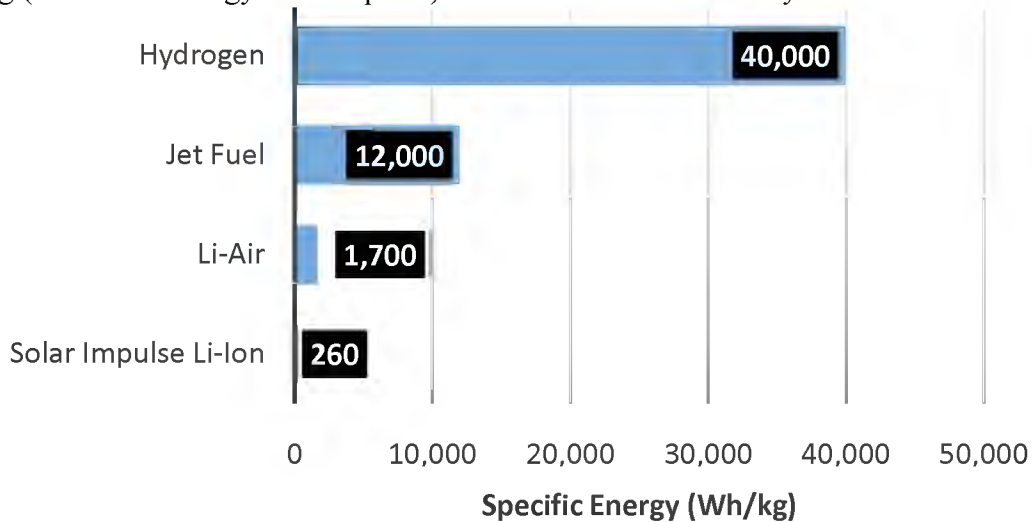
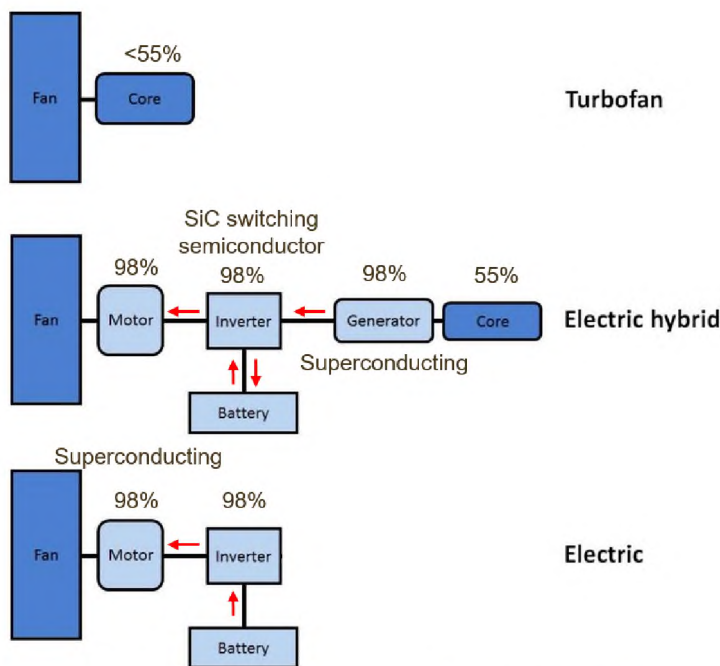

Fig.2. Specific Energy of Potential Energy Sources

For gas turbine powered aircraft, engine maintenance cost is a significant contributor to overall aircraft maintenance cost but is only a weak function of engine thrust, and this is part of the reason why most commercial aircraft have only two engines. Electric motors are reliable and almost maintenance-free, so the designer can choose to have many small engines, which offers flexibility in location, and integration with the stability and control system. This can offer benefits in both aerodynamics and is essential for stability and control. The latter is especially valuable if the aircraft is controlled autonomously.



Source: © Leeham News

Fig.3. Electrical Propulsion Options

Innovative design concepts have already flown, and many new innovations will undoubtedly appear. Designs may broadly be divided into two categories: vertical takeoff and landing (VTOL), and conventional takeoff and landing (CTOL).

Propulsion systems may be divided into three categories: hybrid/electric (meaning a combination of battery power and hydrocarbon or hydrogen fuel), all-electric (powered by batteries),

and solar-powered all-electric. The first two are compared with a gas-turbine in Fig. 3. VTOL aircraft are mostly all-electric, with some hybrid/electric, and CTOL aircraft are mostly hybrid/electric, with some all-electric. Many of these concepts are enabled by computer-controlled thrust management systems, in which engine thrust is closely linked to the aircraft stability and control system, and usually navigation system, allowing a high level of automation. This poses many challenges for aircraft certification which cannot easily be addressed in the conceptual design phase.

### 3.1. Vertical Takeoff and Landing

Aircraft designed for vertical takeoff and landing obtain lift during these phases of flight either from propellers or ducted fans. During cruise, lift can be provided either by propellers or from a fixed wing.

**3.1.1. Hybrid/Electric:** Examples of this category include the E-Volo Volocopter [10], which has 18 fixed-pitch two-bladed propellers, with a maximum takeoff gross weight (MTOGW) of 450 kg (1000 lb), and capacity of 1-, 2-, or 4-seats. It has a 20-30 minute endurance per charge in all-electric configuration, and one hour in a hybrid configuration.



Source: [cleantechincubator.com](http://cleantechincubator.com)

Fig. 4. E-Volo Volocopter



Source: <http://www.ehang.com/article/p/2.html>

Fig.5. EHang 184

**3.1.2. All-Electric:** The EHang 184 [11] is about 1.5 m ( high and weighs 240 kg ( The EHang 184 has a load capacity of 100 kg, and has a maximum output of 152 kW powered by eight motors. It is designed to have the capability to carry a single passenger for 25 minutes' duration flight at sea level at average cruising speed of 60 km/h. A more recent version, the EHang 216, seats two, and has 16 rotors.

An Airbus-funded project, the A<sup>3</sup> Vahana [12] is based in California. This tilt-wing aircraft carries a single passenger with a total payload of 115 kg (250 lb) and trade studies include ranges up to 200 km (125 miles). First flight of a prototype was on January 29, 2018. For intra-city operations, battery recharge times are also an issue, and batteries may need to be switched out after each flight.



Source: <http://evtol.news/aircraft-verdego/>

Fig.6. A<sup>3</sup> Vahana



Source: <https://lilium.com/technology/>

Fig.5. Lilium Jet

Other innovative designs include the Lilium Jet [13] and the Opener BlackFly [14]. The Lilium Jet has 24 fans on the wing, and 12 fans on the canard. The fans are essentially attached to the top of the flap on each lifting surface. The aircraft can take off

and land vertically, but it can also augment low-speed wing lift by having the fans draw air across the top of the wing, offering the possibility of short takeoff and landing (STOL) operations at a higher gross weight. A drawback of this configuration is that the fans operate in a non-uniform flowfield due to the wing boundary layer, and may have to use a non-optimum operating point to avoid blade stall. The first flight was in April 2017, and flights so far have been remotely-piloted. Maximum range of 295 km is claimed.

The Blackfly is probably the most innovative design so far. Tandem wings, each with four propellers, are attached to the fuselage at an angle of about  $-45^{\circ}$ . On the ground, the aircraft sits on its curved belly. To takeoff, the airplane rotates whilst still on the ground using thrust from the forewing propellers until the propellers provide vertical thrust. Then full thrust is applied to all propellers and the airplane lifts off the ground. For cruise flight the aircraft rotates nose down until the wings are at cruise angle of attack. The process is reversed for landing. This airplane has an empty weight less than 115 kg (254 lb), and can operate as an ultralight under FAR Part 103, which restricts it to a maximum speed of 28 m/s (54 kt). The first flight was in October 2017, and the airplane has flown over 19,000 km (10,500 nmi) since then.



Source: [www.opener.aero](http://www.opener.aero)

Fig. 6. Opener BlackFly

### 3.2. Conventional Takeoff and Landing

Conventional takeoff and landing implies an available runway length of at least 600 m (~2000 ft). Few airports are close to the city center, with a few exceptions such as London City Airport (LCY), or Toronto City Airport (YTZ). Because of the time taken to get to and from the airport, this suggests that the minimum range must be of the order of 500 km (270nmi). This is difficult for an all-electric aircraft, so hybrid/electric is often the preferred choice of propulsion.

**3.2.1. Hybrid/Electric:** Examples of this class of aircraft include the Zunum Aero [15]. The program is supported by Boeing, JetBlue, and Washington State. This twin-propulsor aircraft has a claimed range of 1124 km (610 nmi). Batteries occupy most of the wing, and a small turboshaft is in the rear of the fuselage to keep the batteries charged as required. Externally the aircraft looks conventional, and the design does not take advantage of distributed propulsion. The design assumes a battery specific energy of 300 Wh/kg, so this would require more advanced battery chemistry than Li-ion.



Source: [techrunch.com](http://techrunch.com)

Fig.7. Zunum Aero

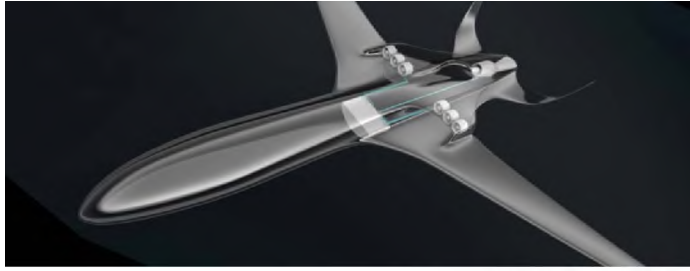

Fig.8. Airbus E-Thrust Airliner

An aircraft concept for the longer term is the Airbus E-Thrust Airliner [16], which will use six electrically driven fans, with a combination of batteries and a turboshaft driving a generator in the rear fuselage. The ducted fan location offers some noise shielding to those on the ground, but gives up the weight reduction from wing root bending relief.

Airbus states that the aircraft will need batteries with a capacity of 800 Wh/kg to be economical.

**3.2.2. All-Electric:** NASA's X-57 Maxwell [17] is another good example of the potential synergy with the use of electric propulsors. The aircraft is a much-modified Tecnam P2600T light piston-engine twin. Propulsion consists of two tip-mounted propellers for cruise, plus twelve fixed-pitch two-bladed propellers for takeoff and landing. The slipstream from the two-bladed propellers enables the design wing loading to be increased from the original design's value of 83 kg/m<sup>2</sup> (17 lb/ft<sup>2</sup>) to 244 kg/m<sup>2</sup> (50 lb/ft<sup>2</sup>). It may also be possible to reduce vertical stabilizer area [18], although that was not done for this aircraft.



Fig.9. NASA X-57 Maxwell

For a design range greater than about 2000 km (1080 nmi), an all-electric configuration is infeasible for the foreseeable future. For the Boeing 787-900, fuel weight is about 40% of takeoff gross weight, and payload about 11%

**3.2.3. Solar Power:** The best-known solar-powered aircraft is the Solar Impulse 2 [19], which completed a circumnavigation of the earth in July, 2016. This aircraft had a gross weight of 2,300 kg (5,100 lb) and span of 71.9 m (236 ft). Battery specific energy was 260 Wh/kg. The typical flight profile overwater was to climb to 28,000 ft. during daylight hours. After dark, it would glide to 5,000 ft. at which time the batteries provided power to maintain that altitude until the sun provided enough power to climb again. The longest segment, from Nagoya to Hawaii, took almost 5 days.

The problem of solar-powered flight is simplified if the pilot and cockpit are removed. The Airbus Zephyr High Altitude Pseudo-Satellite (HAPS) [20] flew for 26 days, finally landing on August 8, 2018. It had a gross weight of only 75 kg (165 lb). Its daytime cruise altitude was 69,000 ft and minimum nighttime altitude was 55,000 ft. Solar-powered aircraft are not feasible for passenger-carrying, but they may be used for very long endurance surveillance, or other application currently carried out by satellites. Parametric weight estimation methods for pilotless aircraft are available



Fig.10. Airbus Zephyr



from Gundlach [2].

#### 4. FUTURE AIRCRAFT ENERGY:

One possibility is the use of nanoelectrofuel [21] using charged nanoparticles suspended in a water-like liquid, as shown in Fig. 13. The propulsion system will be similar to that of an aircraft with electric power from a hydrogen fuel cell. The hydrogen tank is replaced by separate tanks for positively- and negatively-charged fuel, and discharged fuel. Specific energy up to 750 Wh/kg may be achievable, and this could see application to short haul aircraft.

For long-haul aircraft, the best option for reduced carbon emissions may be to recycle CO<sub>2</sub> using carbon capture and fuel synthesis, possibly using alkane reverse combustion [22]. The resulting optimal fuel blend may be a hydrocarbon that is not like kerosene, so this may involve combustion chamber modification, but is unlikely to affect design at the conceptual stage

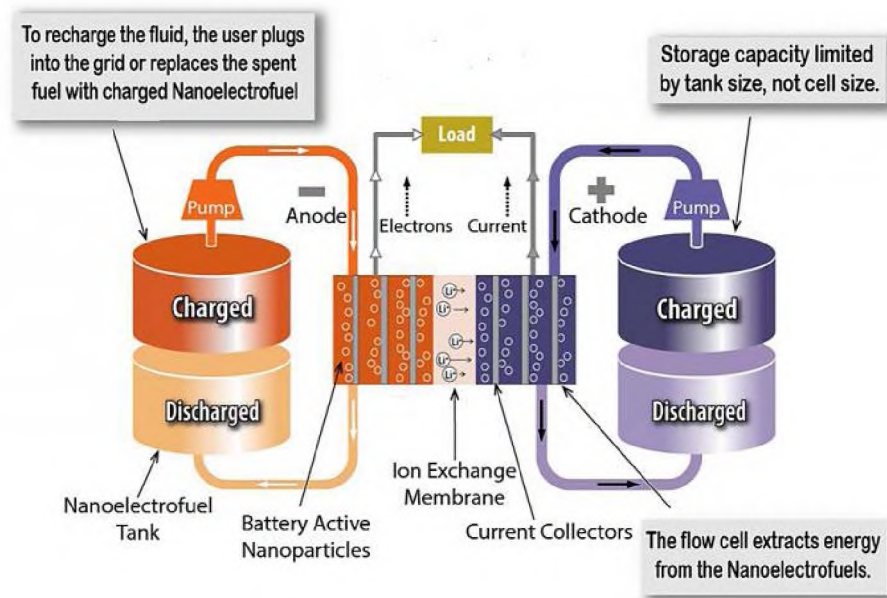

Source: *AIJST Aug 20-24 2018*

Fig.11. Nanoelectrofuel system

#### 5. CONCLUSIONS

A clear path to the future of aircraft propulsion is unknown, and this gives students many opportunities for innovative designs. They will have to do a significant amount of research, and much of the information is not yet available in textbooks. Fortunately, much of the required information is available on the internet, somewhere. For intra-city operations, all-electric battery-powered aircraft, either rotary-wing or tilt-wing, will become common. But there are plenty of opportunities for innovative concepts. For intercity operation, hybrid propulsion systems are more likely. For long-haul, hydrocarbon fuels will not be replaced in the foreseeable future.

## REFERENCES

- [1] Anon., “Switching to renewables will not be as rapid as many hope”, *The Economist*, 15 March, 2008
- [2] J. Gundlach, “Designing Unmanned Aircraft Systems, A Comprehensive Approach”, AIAA Education Series, 2012
- [3] D. Raymer, “Aircraft Design: A Conceptual Approach”, 6<sup>th</sup> Edition, AIAA Education Series (to be published)
- [4] G.D. Brewer, “Aviation usage of liquid hydrogen fuel – prospects and problems” *International Journal of Hydrogen Energy*, Volume 1, Issue 1, Elsevier, 1976
- [5] Anon, “Flight International”, 9 May 1981
- [6] B. Khandelwal, P. Sekaran, A. Karakurt, V. Seshi, and R. Singh, “A Review of Hydrogen as a Fuel for Future Air Transport”, AIAA 2012-4267, 48<sup>th</sup> AIAA/ASME/SAE/ASEE Joint Propulsion Conference and Exhibit, Atlanta, GA, July-August, 2012
- [7] G. Warwick “Electric-Propulsion X-Plane Is Just First Step”, *Aviation Week & Space Technology*, Jun 26, 2015
- [8] Anon, “Commercial Aircraft Propulsion and Energy Systems Research: Reducing Global Carbon Emissions, Ch. 4 Electric Propulsion”, *The National Academies Press*, 2016
- [9] Anon, [https://www.dlr.de/tt/en/desktopdefault.aspx/tabid-10743/19267\\_read-44808/](https://www.dlr.de/tt/en/desktopdefault.aspx/tabid-10743/19267_read-44808/)
- [10] Anon, <https://www.volocopter.com/en/>
- [11] Anon, <http://www.ehang.com/news/137.html>
- [12] Anon, <https://www.airbus-sv.com/>
- [13] Anon, <https://lilium.com/>
- [14] Anon, <https://www.opener.aero/>
- [15] Anon, <https://zunum.aero/>
- [16] Anon, <http://company.airbus.com/service/mediacenter/download/?uuid=64ea2c23-91b1-4787>.
- [17] Y. Gibbs (Ed.), <https://www.nasa.gov/centers/armstrong/news/FactSheets/FS-109.html>, November 2017

[18] G.T. Klunk, J.L. Freeman “Vertical Tail Area Reduction for Aircraft with Spanwise Distributed Electric Propulsion”, 2018 AIAA/IEEE Electric Aircraft Technologies Symposium

[19] Anon, <https://solarimpulse.com/>

[20] Anon, [www.airbus.com/UAUV/Zephyr](http://www.airbus.com/UAUV/Zephyr)

[21] G. Warwick, “Liquid Battery Promises Safe Energy-Dense Power for Electric Aircraft”, Aviation Week & Space Technology”, August 14, 2018

[22] W. Chanmanee, M.F. Islam, B.H. Dennis, and F.M. MacDonnell, “Solar photochemical alkane reverse combustion”, Proceedings of the National Academy of Sciences, January 2016

### Author



Anthony P. Hays

### INFORMATION ABOUT THE AUTHOR

Tony Hays started work in the aerospace industry in 1962 as an apprentice at Bristol Siddeley Engines Ltd. (later absorbed into Rolls-Royce). He earned a B.Sc. from Bristol University in 1965 and an M.S. from MIT in 1971. He has worked for numerous aerospace-related companies in the U.K., Canada, and the U.S. Most of this work was in the area of aircraft advanced design. He has taught classes in aircraft conceptual design at Northrop University, University of California San Diego, California State University Long Beach, and Nanjing University of Aeronautics and Astronautics.

## WORK EXPERIENCE AT NUAA SUMMER LECTURE PROGRAM

**Liia Makarova**

Kazan National Research Technical University named after A.N. Tupolev - KAI  
Department of Aerohydrodynamics  
10, K. Marx Str., Kazan, Republic of Tatarstan, 420111, RUSSIA  
e-mail: [LAMakarova@kai.ru](mailto:LAMakarova@kai.ru)

**Key words:** Engineering Education, International exchange programs.

**Abstract.** *This paper provides a general analysis of the International Lecture Program – NUAA Summer Lecture Program; it discusses organizational questions, aims of this program, expected results, and makes recommendations.*

### 1. INTRODUCTION

Presently, many different international exchange programs exist, ranging from academic exchange programs for students, double degree programs to large joint international research. Examples are Fulbright (USA) [1], DAAD (Germany) [2], Newton International Fellowship (UK) [3] etc. However, in most cases, all these programs are aimed at joint scientific and research work, leaving aside educational activities. However, also high quality engineering education is an integral part of the further success of scientific research. Here, the international initiative of Nanjing University of Aeronautics and Astronautics (NUAA), the "NUAA Summer Lecture Program" (in short: Summer School) is a unique tool related to the exchange of modern education in engineering. It should be mentioned here something that is very similar to the "NUAA Summer Lecture Program" (but in a somewhat extended format). It is the Global Initiative for Academic Networks (GIAN) [4], provided by the Government of India. From the point of view of creating a contemporary effective engineering education system, including training of engineering personnel, these programs are a powerful tool. This article reflects briefly upon the organization of the Summer School, its benefits for NUAA's students, the benefits for international teachers, and recommendations for improving the Summer School.

### 2. ORGANIZATION OF THE SUMMER SCHOOL

In February 2015, the KNRTU-KAI's Office of International Activities had provided information about the "NUAA Summer Lecture Program". The information was placed on KNRTU-KAI's website. It should be noted that this was done only once. Later, the information about the Summer School was never posted again on KNRTU-KAI's website, the reasons could be: 1. NUAA didn't send the information about the Summer School to KNRTU-KAI anymore. 2. The KNRTU-KAI's Office of International Activities did not post

the information. During all the later years, the information about the start of the NUAA Summer School program was received by letter via e-mail.

For the majority of the young teachers from Russia it is the first experience of lecturing in English. Young teachers from Russia are otherwise fortunate, if they have an opportunity of interacting with English-speaking scientists in research activities, or through participation in international projects. That is why the participation in the competition to be a lecturer in the international Summer School is a big and important step in the development of your own international activity. Moreover, the conditions offered by the Chinese side seemed more than tempting: a refund of travel expenses, accommodation and a good salary are offered. The rules in the competition for participation in the program are as follows: It is necessary to fill in a very simple form. The form asks for a brief résumé and the content of the course. This information is sent to NUAA. After that, the course is offered to students. The students choose among different courses and if the required number of students has enrolled in your course, an invitation to participate in the Summer School is sent. The organization of the Summer School at NUAA for the teacher looks very simple, especially in comparison to similar attempts in other countries. Everything that is necessary is: Arriving at Nanjing, checking in to the hotel, delivering the lecture, and receiving the payment. There are no endless numbers of papers, official statements, certificates, documents, or signatures necessary. Everything works just fine. **The organization of the Summer School is simple and reliable; there are no unnecessary mechanisms in it that could lead to a breakdown of the system.** It is necessary to mention the schedule. It is done extremely well. Firstly, it allows using classroom time to a maximum effectiveness. Classes are held throughout the day from 8.30 to 21.00. Secondly, all teachers have the same conditions. Thirdly, the schedule allows planning excursions, sightseeing of the city (in any case, it is an integral and important part of any international program).

To each teacher an assistant is attached, he/she participates in checking student attendance, helps to solve possible problems, and sometimes takes the initiative in organizing the free time of the teacher. The lecture room is equipped with all necessary technical equipment: computer, projector, and board.

### **3. BENEFITS OF THE SUMMER SCHOOL FOR NUAA'S STUDENTS**

In my four years of participation in the summer schools, I had from 24 to 40 students in the group; all of them were united by one quality: avoiding the dialogue with the lector in any way. It can be assumed that reasons for this are in the following: Embarrassment because of "bad" English, a general fear of the teacher, an additional fear of a foreign teacher. In about **20%**, the lector's labor was associated with constant attempts to communicate with the audience. Approximately **5% to 7%** of students – after much work in organizing a communication – eventually started asking questions, answering questions, and entering into a discussion about the material and the tasks. Moreover, it is worth noting that students understood about **90%** of the information, but they refused to speak. It is also necessary to add that it is more effective to approach students individually. In contrast, it is a very difficult task, addressing the students as a group. If the group is asked, none of the students wants to give an answer or to take responsibility. Students seem to hope that perhaps another classmate will answer. If the lector asks a specific student a question, he/she may find the right words, giving a qualitative answer in the end in most cases. It can be concluded that in general, students have a huge fear of giving a wrong answer to the question. They prefer not to risk getting – as they think – in an embarrassing situation. They prefer to wait, for a more decisive and initiative classmate. In this regard, a correct approach of the international teacher during

**the NUA Summer School could be a very valuable help to NUA students in the development of communication skills in their subject and could foster their scientific interest.** One of the most important tasks of the Summer School is to overcome the student's fear of communicating with a foreigner, and even more so, with a foreign teacher.

#### **4. LEVEL OF SUBJECT KNOWLEDGE OF NUA'S STUDENTS**

I was giving the course "Advanced Fluid Dynamics". It can be attributed to the basic course, taught in most aviation specialties (Fig. 1). Close to the 4th to 5th day of the lecture, some students bring with them textbooks on Mechanics of Fluids for their "insurance", unfortunately, in Chinese language. From the first classes, I recommended students, to bring additional literature in English, since **one of the most important tasks is learning of terms from the subject area in the English language.**

Students have a good knowledge in integral and differential calculation; they are good at solving tasks where it is necessary to use their available knowledge. However, any task that requires a non-trivial solution causes difficulties. In general, students have an excellent training in the solution of a wide range of tasks, but a weaker ability in solving non-standard tasks. The level of knowledge of Master students is higher than that of Bachelor students.



Fig.1. Course of Advanced Fluid Dynamics provided at NUA Summer School

Thus, it is necessary to note the following main goals, which are pursued by the organizers of the NUA Summer School with respect to their students:

- 1. Improve communication skills in the English language with foreign lectors.**
- 2. Increase the vocabulary of highly specialized terms in the field of the studied subject.**
- 3. Directly get and improve knowledge in the subject area.**
- 4. Increase the future perspective of students by letting them interact with lectors of other countries and other methods of teaching.**

#### **5. BENEFITS OF THE SUMMER SCHOOL FOR INTERNATIONAL TEACHERS**

The NUA Summer School allows international teachers to get acquainted with teachers from different countries and from different subject areas. In my case, I came e.g. in contact with Prof. Dieter Scholz (Germany) who was teaching "Aircraft Design" [5]. Fig. 2 shows him with his NUA student group.

Compared to scientific conferences, where the focus is on the exchange of the research experience, here the focus is on the exchange of teaching experience and on the implementation of educational methods. Teachers have also the opportunity through a personally assigned assistant to arrange a meeting with the department with similar research interests, establish contacts, and organize cooperation. The Summer School is an important tool for developing international educational skills for teachers, for whom English is a foreign language. The participation in the Summer School is a very valuable experience; it is possible to get the following:

- 1. The experience of lecturing in English.**
- 2. The experience of interaction with foreign students.**
- 3. The possibility of assessing and comparing the knowledge and skills of students from another country, trained in another educational setting.**
- 4. The confidence to lecture in English in cases of another invitation from another country.**
- 5. Extra earnings.**



Fig.2. Students of the Summer School in the NUAU Aviation Museum [5]

## **6. CONCLUSIONS AND RECOMMENDATIONS**

From the above it can be concluded that the implementation of such initiatives as the NUAU Summer School is an important component of engineering education. Disadvantages that cannot be avoided: It is very difficult to provide a sufficiently large amount of information in the short time available; students do not have enough time to absorb the information. A possible improvement would be to organize feedback from the students. A questionnaire should be developed for the students to fill out at the end of the course. The results could be sent to the lecturer by the organizers of the NUAU Summer School.

## REFERENCES

- [1] <https://us.fulbrightonline.org>
- [2] <https://www.daad.de/en>
- [3] <http://www.newtonfellowships.org>
- [4] <http://www.gian.iitkgp.ac.in>
- [5] <http://AircraftDesign.ProfScholz.de>

## ACKNOWLEDGEMENT

The cooperation with Prof. Dieter Scholz from Hamburg University of Applied Sciences in writing this paper is greatly acknowledged.

### Author



Liia Makarova



## FLIGHT ON A PASSENGER PLANE AS THE PROCESS TO STUDY THE AVIATION BASICS

Clifton Read<sup>1</sup>, Anatolii Kretov<sup>2</sup>

1 – Executive Wisdom Consulting Group, Brisbane, Australia  
68 Mayfield Road, Carina 4152 QLD Australia  
e-mail: [cliftonread@v7mail.com](mailto:cliftonread@v7mail.com)

2 – Nanjing University of Aeronautics and Astronautics, College of Aerospace Engineering,  
29 Yudao St., Nanjing 210016, P.R. China  
e-mail: [kretov-ac@nuaa.edu.cn](mailto:kretov-ac@nuaa.edu.cn)

**Key words:** Teaching Methodology, Aircraft Design, First-Year Students, Nanjing University of Aeronautics and Astronautics

**Abstract.** *A method of teaching the basics of aviation for first-year students studying in the field of aircraft design is proposed. The article deals with a list of questions on the basics of aviation, the answers to which, supported by the students' real experiences as passengers, will help them to better understand the structure of the aircraft and significantly increase the students' interest in their future activities in the field of aviation.*

### 1. INTRODUCTION

Working with students in the various disciplines of aviation education, we are able to point out to them the very obvious progress that is continually being made in the capabilities and efficiencies of the aircraft and their many and varied systems on which they rely. For example, in the 1960's, a Boeing B707 with 4 engines could carry up to 180 passengers ~6,700km cruising at around 500 knots. A trans-Pacific flight from the US to Australia encompassed 3 legs: Sydney – Nadi (Fiji) – Honolulu – LA. Today a twin-engine B787 carrying twice the number of passengers can fly from Sydney to LA in one hop.

Simultaneously however, we can also notice an increasing isolation of knowledge of students from understanding the physics of the processes. Often, the sheer volume of information that we find is not always necessary nor useful for learning, and more and more, the growing habit of the modern student to quickly find a ready answer through the internet rather than searching, calculating and experiencing often generates a marked state of isolation from the understanding of the essence. As we are all aware, knowledge of the issue and its understanding is not the same thing. As the old adage goes, knowledge is knowing that tomato is a fruit. Understanding is not putting it in a fruit salad.

In this regard, a large role belongs to the disciplines designed to introduce students to their future profession. As a rule, such disciplines are read in the first year, often they are performed credit work in form of report, essay, abstract. One version of such work (reports) will be discussed in this publication.

Working with aircraft during all stages of its life cycle (design, construction, testing, operation) is one of the most complex areas of human activity and one which demands the highest standards of responsibility. When several hundred people are on board an airliner, their

lives depend upon many essential and interconnected components: how the aircraft is designed, how it is made, how it is serviced, how carefully the control is carried out when seating the passengers, and how the cargo are loaded, how the pilots will respond and operate in case of an emergency. At each of these stages, the outcomes will depend on those responsible for making the crucial decisions. Often, responsible employees have to deal with non-standard questions, the answers to which can be found only by understanding the physics of the process.

Working at a university we can observe this scenario. A student who loves aviation and who has come to study at the University to create his aircraft, plunges into the complex issues of the various disciplines but is gradually forced to forget his most passionate component – his dream. Not having had time to understand the basics of aviation technology he plunges deeper into many important and necessary issues. If we analyze the biographies of the great aircraft designers, most of them have passed all stages of the life cycle of the aircraft (design, construction, flight tests, commissioning).

I (*C.Read*) have also observed this process in the pilot program, where some students arrive with a naïve enthusiasm but very little in the way of actual knowledge or experience in aviation. When I first began with the student pilots in 2013, I conducted a series of straw polls in the classes and was very surprised to find approximately 70-80% of the students who had, after a comprehensive and challenging selection process, signed on to become a pilot, had never actually flown in an aircraft of any description. Continuing the polls, we noticed a marked change over the next 5 years, to the extent that I would estimate that now less than 50% arrive for the first class having never flown. This radical change is most likely a consequence of the burgeoning middle class in China, where more and more families can afford to fly, which in turn is one of the principal drivers in the rapid growth of Chinese commercial aviation.

However, I (*C.Read*) also noticed that as the semester wore on, the complexities of the basic knowledge they needed to acquire, and the demands of the study workload set in, the enthusiasm started to wane. It was at this point that many of the students would reveal their true motivation: status and salary. Without any real practical experience of the joys of aviation, and no underlying base to drive them on, students lack the will to grind on through the tough times. In countries where there is a mature aviation industry, there is also a grassroots aviation community which is the feeder for the industry, so the process of getting into aviation is usually the reverse: people fall in love with flying after acting on an initial interest by buying magazines, going to an airshow, or going along to their local aerodrome and getting involved. As there is no grassroots aviation in China, there is really nowhere for this to happen.



Fig.1. Flight through the eyes of the pilot and passenger

Currently, the most effective ways of such entry into aviation are classes in flying clubs and aircraft modeling. While quite real, these interactions have their limitations related to the physical and other capabilities of students.

So, how do we help students who are just taking their first steps towards aviation technology, and how do we create better and more accessible methods for them to understand the basics? It is obvious that this is a difficult, but very important and topical methodological issue.

## 2. PROPOSED METHOD

The technique offered by the authors is quite simple and natural and is proposed in addition to all other existing methods and course matter. Due to the nature of the method being a starting point, it would be most effectively employed as a precursor or prerequisite to beginning first year coursework. The details of the task (the format and list of questions or suggested observations) could, for example, be given to the student at the time of enrollment or course acceptance. The report that the student would submit would of course be assessed and contribute to their overall grade. As previously mentioned, most students now have been passengers on a commercial flight. This flight is the basis of the method.

In order to begin the topic, the student must find the necessary information about the particular aircraft.

1. Determine the brand, type and variant. *For example: Airbus A320; Boeing B737-800, etc.*
2. Hand-draw the aircraft: front and side and top cross-sections.

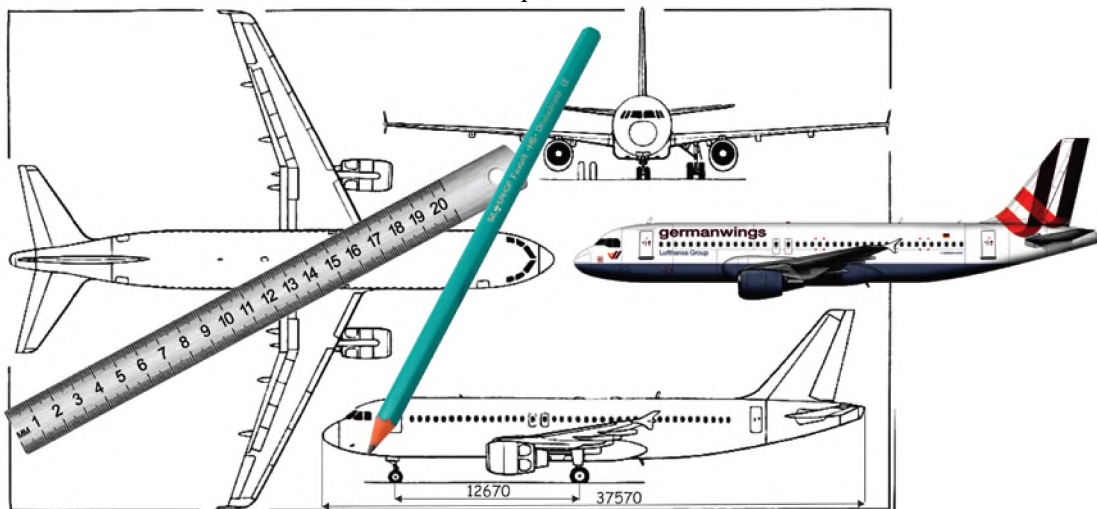

Fig.2. Manual drawing of the aircraft scheme

While there are many computer tools available that will do this, it is far more beneficial for the student to do it by hand. Accuracy in this exercise is secondary to creating a connection with the contours of the aircraft, to understand the logic of the design, the location and scale of the component parts: the fuselage, the wings, the engines, the empennage and landing gear.

The student should be able to feel the art and harmony inherent in the vehicle that stands before him.

3. Give the basic characteristics of the aircraft.

*For example: Airbus A-320*

Cockpit crew: 2;  
Exit limits: EASA (The European Aviation Safety Agency)/FAA(Federal Aviation Administration US):195/190; 1-class max. seating:186 at 74 cm pitch; 1-class, typical: 164 at 81 cm pitch;  
Cargo volume: 37.40 m<sup>3</sup>  
Unit load devices: 7× LD3-45  
Overall dimensions: Length: 37.57 m  
Wheelbase: 12.64 m  
Track: 7.59 m  
Wingspan: 35.8 m  
Wing: Area: 124 m<sup>2</sup>  
Aspect ratio: 10.3  
Wing sweepback: 25°  
Fuselage: Height: 4.14 m  
Width: 3.95 m  
Cabin Width: 3.70 m  
Tail height: 11.76 m  
  
Mass characteristics: MTOW (Max. Takeoff Weight): 78 t  
Max. payload 19.9 t  
Fuel capacity: 24,210–27,200 L  
OEW (Operating Empty Weight): 42.6 t  
Speed (Cruise): Mach 0.78 (829 km/h)  
MMO (Maximum Operating Mach Number): Mach 0.82 (871 km/h)  
Range (typical payload): 6,100 km  
Takeoff run (MTOW, SL, ISA): 2,100 m  
Landing (MLW, SL, ISA): 1,500 m  
Service ceiling: 11,900–12,500 m  
Engines (×2): IAE V2500A5 (1.61 m fan)  
Thrust (×2): 98–120 kN

4. Using a combination of knowledge gained from pre-flight reading, any pre-course research into aviation technology and technical characteristics of the aircraft, and personal feelings during the experience, develop an analysis of the flight characteristics of the aircraft.

4.1. Boarding, loading and seating procedures:

Take your seat and buckle your seat belt, observe pre-takeoff procedures of the cabin crew and ground crews, if you can see them. You may hear or feel an engine running but the main engines are not running – what is it? The aircraft moves backwards away from the aerobridge: pushback from the tug.

4.2. First one engine begins to spool up, it starts, then the second engine, and the plane is taxiing on the taxiways towards the runway. You may have to wait in a queue or for the dispatcher's permission to take off. You can see from the window, as the flaps are put forward in the intermediate position.

4.2.1. Approximately what angle are the flaps set at?

4.2.2. Draw a cross section of the wing and this take-off position of flaps.

4.2.3. Explain the effect that gives this position of the flap, using the concept of lift coefficient, drag coefficient, flap deflection angle.

4.3. The plane begins its takeoff run, the speed increases, and you feel the aircraft tilt back and the wheels break free of from the runway.

4.3.1. How much time did it take from the start of the run to the break?

4.3.2. What is the approximate speed of the aircraft at this point?

4.3.3. Considering the movement is uniformly accelerated and knowing the maximum length required for the take-off of the aircraft, try to agree on the values of paragraphs 4.3.1 and 4.3.2.

4.3.4. Draw a graph of the load change on the chassis over time during takeoff and explain it.



Fig.3. Wing loading during take-off

4.3.5. What percentages of the total mass are fuel and payload?

4.4. Your plane is gaining altitude you feel that the engine is running at maximum.

4.4.1. What is the thrust-to-weight ratio at the maximum take-off weight of the aircraft and maximum thrust?

4.4.2. Why is it necessary for a vertically launching rocket to have a thrust-to-weight ratio of more than one, while for a horizontally-taking off aircraft it is much smaller?

4.4.3. Draw a profile of the wing (cross-section along the flow) and explain how lift is generated.

4.4.4. How will a change in the angle of attack affect the magnitude of the lift force assuming a constant velocity?

4.4.5. What will happen to the aircraft if the angle of attack exceeds a critical value?



Fig.4. What are the signs by which you can determine – it is takeoff or landing

4.5. Speed and altitude of your aircraft are increasing.

4.5.1. You can see the flaps retracting. Why does the pilot retract the flaps?

4.5.2. What pitch angle do you feel when you climb?

4.5.3. Show on the side projection diagram what forces act on the aircraft.

4.5.4. What proportion of thrust is spent on climb and how it is related to the pitch angle?

4.5.5. The plane collides in the air with a foreign object (drone, bird). What do you think is the weakest place in the plane in such a collision and why?



Fig.5. The meeting an airplane with a drone and its consequences

4.6. The pilot of the aircraft changes its course.

4.6.1. How to ensure a reversal of course?

4.6.2. Why do you feel a certain increase in your weight during a turn (with roll)?

4.6.3. What is a load factor (overload)?

4.6.4. Draw a diagram of the aircraft from the front with this maneuver and show all the forces.

4.6.5. How do you estimate the magnitude of the overload during this maneuver?

4.6.5. What part of the fuselage will experience minimum load?

4.7. The aircraft is entering the cruise mode of flight

4.7.1. Using a picture of the side projection of the aircraft explain all acting forces.

4.7.2. What is the load factor (overload) in horizontal flight at a constant speed?

4.7.3. At what altitude is your cruising flight?

4.7.4. What is the outside temperature?

4.7.5. How can the pilot change the altitude – what are his actions on the command levers and the reaction of aerodynamic control surfaces?

4.7.6. In case of transition to a higher altitude, how should the pilot change the mode of operation of the engines?

4.7.7. Assess the deflection at the end of the wing. It is more convenient to do this in relative units (for example, in relation to the length of the wing).

4.7.8. Will the deflection be greater at the beginning of the flight or at the end and why?



Fig.6. Flight of turbulence mode

4.8. You feel a slight vibration of the aircraft. There is an announcement: "We may encounter some turbulence, please fasten your seat belts".

4.8.1. Explain the physics of the influence of turbulence on the aircraft.

4.8.2. What is the maximum amount of overload which can act on you during turbulence?

4.8.3. What will happen to the aircraft in the event of a sudden failure of one of the engines?

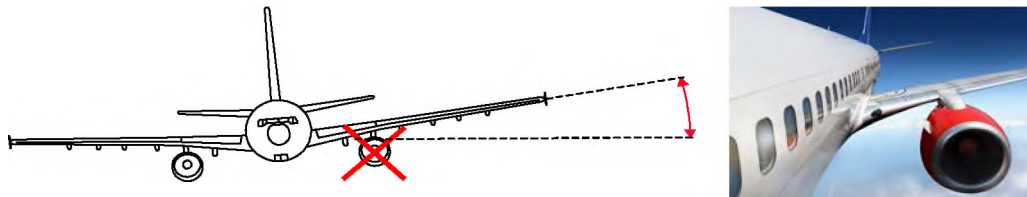

Fig.7. The failure of one of the engines

4.8.4. How will the aircraft be balanced? Explain it with the help of the drawn diagrams of the plane.

4.8.5. If, at an altitude of 10 km both engines stop. Approximately what distance (range) will the aircraft be able to glide to make an emergency landing?

4.8.6. What are the aerodynamic loads on the fuselage, and what is the wing loading during cruise?

4.8.7. What are the consequences of a lightning strike on the aircraft?

4.9. Your flight is coming to an end. The plane begins to descend.

4.9.1. How does the autopilot operate a descent mode?

4.9.2. How do the positions of the control surfaces (primary and secondary) change during the descent?

4.9.3. The pilot lowers the landing gear. What changes will he make to the operations of the engines during this phase?

4.9.4. What can happen to the aircraft if it suddenly finds itself in a cloud of smoke and dust from an erupting volcano?

4.9.5. The pilot suddenly saw a foreign object on the runway. What are his actions? How will passengers feel the pilot's actions?

4.9.6. If the aircraft has to land on a wet runway, how will the landing technique change to accommodate this?



Fig.8. Aircraft landing

4.10. The aircraft touches down.

4.10.1. What is the landing speed of the aircraft?

4.10.2. What will change in the outer contours of the wing at the same time? What control surfaces will be used?

4.10.3. Not long after touchdown, the sound of the engines changes. In what mode do the engines operate after the aircraft touches down?

4.10.4. Estimate the value of load you experience by the uniform acceleration if the braking distance is 400 m.

4.11. After taxiing off the runway, the aircraft parks at its gate.

4.11.1. How much fuel should remain in the tanks after a maximum range flight with the full number of passengers?

4.11.2. Passengers get off the plane, airport staff begins to prepare the aircraft for the next flight. What kind of internal and external work will be carried out at this point?

The second year for masters is devoted entirely to individual work with the supervisor on the topic of graduation work. If necessary a student can listen to additional subjects, related to the specifics of his thesis.

### 3. CONCLUSIONS

It is very important that every moment of the flight on the plane of a person associated with Aircraft Design was extremely useful for him to realize the knowledge that he has and for the emergence and explanation of issues that he has not yet had to face.

#### Authors



Clifton Read



Anatolii Kretov



## PROJECT-BASED AIRCRAFT DESIGN EDUCATION AT THE HONG KONG POLYTECHNIC UNIVERSITY

WenChih-Yung<sup>1</sup>, Sun Jingxuan<sup>2</sup>

1 – The Hong Kong Polytechnic University  
Department of Mechanical Engineering  
Department of Mechanical and Aerospace Engineering  
Hong Kong  
e-mail: [chihyung.wen@polyu.edu.hk](mailto:chihyung.wen@polyu.edu.hk)

2 – The Hong Kong Polytechnic University  
Department of Mechanical Engineering  
Hong Kong  
e-mail: [jingxuan.j.sun@connect.polyu.hk](mailto:jingxuan.j.sun@connect.polyu.hk)

**Key words:** Unmanned Aerial Vehicle, Final year project, Aircraft system design.

**Abstract.** *This paper presents the project-based aircraft design education in the Department of Mechanical Engineering, the Hong Kong Polytechnic University. The pedagogy of combining the project-based learning and self-learning in aircraft design education method is emphasized. Combining the UAV projects and aircraft design education with the international aircraft design competitions, the students can engage in aerodynamic design, flight performance analysis, control system development, manufacturing, flight tests as well as project management and team working. In the past six years, the aircraft design education has been successfully implemented with final year projects using this efficient pedagogy in the Hong Kong Polytechnic University and has achieved remarkable outputs.*

### 1. INTRODUCTION

Hong Kong is one of the most important aviation hubs in the world [1] and has a good reputation on the aviation services. With the dramatic increase in Chinese and regional air traffic volume, Hong Kong International Airport is building the third runway to seize this golden business opportunity. The quality manpower demand is imminent. To adhere to the spirit of her motto – ‘To learn and to apply, for the benefit of mankind’, and show her determination to serve the Hong Kong society, The Hong Kong Polytechnic University (HK PolyU) set up two new aero-related programs in recent years accordingly – Air Transport Engineering (a top-up program) and Aeronautical and Aviation Engineering (AAE, a 4-year Bachelor degree program). The main educational goal of these two programs is to train and cultivate human resources on the aviation industry and the relevant services [2]. Basic courses, such as, Fundamentals of Aerodynamics, Aircraft Propulsion Systems, Aircraft Structures and Materials, and Flight Mechanics and Control, are offered. However, no specific course on aircraft design is given in the curriculum of each program. It is because Hong Kong is a densely populated region and the available land for the industry is limited; therefore, it is

impossible for Hong Kong to design, manufacture, and test commercial aircrafts such as Boeing 787 and Airbus 380. Nevertheless, to be able to design, build, and test fly an aircraft is still of great interest to many students. Fortunately, the emergence of commercial UAV provides such an opportunity.

The UAVs attract increasing interest due to their immense potential in civil applications and have been developed at a fast pace in recent years [3,4]. With the development of high-powered, embedded computers and open-source flight controllers such as Pixhawk and PX4 [5], the difficulties and cost of developing the avionics and auto-pilot of the UAV are reduced. The students can take advantages of these open-source auto-pilot framework and expand the model aircraft to achieve the basic functions of UAVs. There is no doubt that UAVs serve as a good platform for carrying out project-based aircraft design, which involves aerodynamic design, flight performance analysis, control system development, as well as project management, team working to achieve the objectives of the project. Therefore, to supplement the aircraft design element in the aero-related courses, the UAV Final Year Project (FYP) has been designed and carried out in Department of Mechanical Engineering, HK PolyU for aeronautical education. These projects were proposed with various forms of small UAVs, including bio-inspired flapping wing vehicles (MAV, Micro Aerial Vehicle), UAVs for the search and rescue (SAR) mission, vertical take-off and landing (VTOL) UAVs and etc.. These UAVs have great potential of different applications in Hong Kong and can benefit the local community in the foreseen future. It is believed that Hong Kong has the capability to be a research and design (R&D) center of civil UAVs in China, or even in Asia, if not of big-size commercial aircrafts.

As known, project-based learning and self-learning have been emphasized for years in every university. The FYP is one of the most important examples. The FYP is a required course for Year-4 students in HK PolyU and lasts for one year. The projects can be either conducted by a small team or an individual student, subject to the requirement of the different departments. For examples, one FYP is conducted by a team of 3 students in Department of Mechanical Engineering (ME). Because, the students have other courses while conducting their FYP, the workload and objectives should be carefully considered.

Notably, the students that take the FYP course have very different backgrounds in HK PolyU, involving full-time and part-time students from the undergraduate programs of different departments. Therefore, very likely the students choose the UAV project as their FYP without aero-related or computer programming backgrounds. At the same time, the UAVS projects need to be updated frequently due to the fast development of relevant technologies. One major challenge of carrying project-based aircraft design is how we design the project objectives. With a well-designed project, the students can not only achieve the project objectives but also be trained with relevant knowledge and technologies. What's more, the project should light a fire inside the students on aircraft design and aeronautical engineering. In this paper, the experience of carrying out the project-based aircraft design will be presented.

## **2. BRIEF STATEMENT OF TEACHING APPROACHES**

The paper must be written in English. The full-length paper must have a maximum length of 10 pages. The development of UAVs has become increasingly important over the last decade in the aeronautical engineering community. UAVs potentially have a variety of civilian uses, ranging from searching high-rise buildings on fire, collapsed mine shafts, to probing damaged nuclear power plants for radiation leaks. At the same time, UAVs provide a good example to let the students go through a complete product development cycle from

design, manufacture to tests. What's more, if combined with the external competitions, under the constraints and the limited budget and timeline set by the competition organizers, the students can brainstorm the optimal design and be trained with the good project management and teamwork. It would be beneficial for students to learn how to well manage the project to become good engineers, under strict timeline and budget.

In general, a UAV related project involves airframe design, aerodynamic design, structure design, avionics, auto-pilot system, control system design, project management, and etc. With different UAV applications, it will further involve image processing, computer vision, communication and control (C2) link, localization and navigation problems. Each of these problems can be an individual course or a research topic. Therefore, the projects were designed based on the above-mentioned fundamental aero-related knowledge and an emphasis on self-learning of the other topics. Take the tail-sitter VTOL UAV project as an example. The control system design, especially in a transition phase, is still a major challenge for this type of UAV. The FYP on tail-sitter is to understand different flight phases, and thus conduct the aerodynamic design and structure design in this project. The simulation environment and control system framework were developed by the Ph.D. students who are engaged in related topics. The undergraduate students used the simulation environment to understand and design the cruise controller. In final flight tests, the FYP students and Ph.D. students work together to achieve the project. It is worth noting that mingling the FYP students with the postgraduate students in the laboratory provides a great opportunity for undergraduate students to be involved in the research activities, which will motivate the students to further continue their study and engaged in scientific researches. In the past 6 years, twelve FYP students that involved in the UAV designs continued their postgraduate study in USA, Canada, Taiwan, and Hong Kong.

During the course of carrying out the project-based aircraft design FYPs, various UAV designs were conducted, including the flapping wing MAVs, and the fixed-wing, multi-rotor, vertical take-off and landing UAVs. The COTS (Commercial Off The Shelf) design methodology was adopted and the system integration was emphasized. Using this approach, the vehicles can be designed, manufactured and tested in a very short development cycle, with quick feedback from the test results. Consequently, the students can keep their enthusiasm and nurture the capability of problem shooting. Three typical and successful cases, which are flapping wing MAVs, SAR UAVs and a UAV signal relay system, are presented as follows.

### **2.1. Bio-inspired Flapping Wing MAVs**

The bio-inspired flapping wing MAV is one of the topics that designed for the FYP students. The students designed, analyzed, and built the agile palm-sized bio-inspired flapping MAVs. The gear-ratio reduction mechanism and the vehicle frame were made using the precision machining methods, such as rapid prototyping 3D printing, electrical discharge machining, and laser micromachining techniques. All the other components, such as, motor, avionics, and battery, were bought from the market (COTS). In this way, the students can put together a vehicle and test it in less a month. In the meantime, the experimental research has further been carried out, together with postgraduate students, to understand the aerodynamic characteristic of the current MAV design. In order to relate the flow pattern especially the vortices topology to the force generation, Particle Image Velocimetry (PIV) system has been established as well as the force measurement by the load cell. The experimental research results feed back to the design process and help the students improve the design of the MAV. In this topic, both the two-wing and four-wing flapping wing MAVs, shown in Fig. 1(a) and Fig. 1(b), respectively, were developed and demonstrated in flight [6]. The MAV can carry a

micro camera and transmit live video back to the user. This project has been reported extensively, by Xingtao Daily, Hong Kong.



Fig.1. Flapping wing MAVs of PolyU:  
*a* – two-wing flapping wing MAV; *b* – four-wing flapping wing MAV

## 2.2. Search and Rescue UAV

A series of projects of designing and developing long-range search and rescue(SAR) fixed-wing UAVs were proposed for FYPs since 2012. The aim of this particular type of UAV was to build an all-in-one camera-based target detection and positioning system that integrates the necessary remote sensors for wilderness SAR missions into a fixed-wing UAV. This FYP topic was motivated by Navigated Flight Category of Taiwan Innovative Unmanned Aircraft Design Competition, and the SAR functions integrated into the UAV were developed step by step and year by year. Totally eight groups of FYP students were engaged in this topic. The basic function of the UAV, which includes the necessary autopilot and image system, was achieved in 2012. In 2013, the problem of the C2 link was solved and the beyond visual line of sight (BVLOS) flights (1 km) were successfully tested. The two groups (one full-time and one part-time) in 2014 introduced the auto antenna tracker (AAT) system that expands the distance of C2 link to 4 km. The camera gimbal and targets positioning algorithm were also developed in 2014. The accuracy of targets identification problem was emphasized in 2015 and the onboard targets identification system was developed and integrated with an autopilot system. The function of auto take-off and landing was achieved as well. Hereafter, the basic objectives of this topic have been achieved and additional functions were proposed to improve and optimize the SAR UAV, including targets identification with machine learning, optimal path planning, etc.

The current platform is called “PolyU-Strike” [7], which can fly 30 km in 30 minutes and can also get the GPS coordinates of the searched targets in real time. Onboard, there is a camera-based target detection and positioning system, designed for search and rescue (SAR) purposes. Subsystems of identification and search algorithms, target-detection technologies, and the geo-reference positioning system were developed. The “PolyU-Strike” can autonomously conduct a mission, including auto-takeoff and auto-landing. After the mission, a map of hazard area can be generated to facilitate further logistics decisions and rescue troop actions.

The “PolyU-Strike” has clinched the championship title of Navigated Flight Category in the 2016 Taiwan Innovative Unmanned Aircraft Design Competition, organized by National Cheung Kung University (NCKU), Taiwan [8]. In the competition, it has successfully completed the Intelligence, Surveillance, and Reconnaissance (ISR) mission in a wide coverage in 40 minutes and recognized all 6 targets by applying real-time imaging processing

techniques. High-resolution frames of targets with their GPS positions of 10-meter accuracy were reported. During the presentation, the PolyU team also provided high resolution 2D and 3D maps for the searching area based on their flight data, which was highly recognized by the referees. Last but not least, “PolyU-Strike” was the only team which completed all the competition goals set in the competition.



Fig.2. “PolyU-Strike” in the air

### 2.3. UAV Communication Relay System “Mom and Son”

The aforementioned flapping wing and SAR UAV are traditional UAV design and development topics. The innovative and exploratory projects are also valued and encouraged. The UAV communication relay system “Mom and Son” represents a successful and outstanding example. The FYP project was conducted in 2016 and the prototype of a two-UAV communication relay system was developed, which uses a relay and routing to extend the communication range and bypass obstacles at low cost, shown in Fig. 3. This system can solve the communication difficulties between UAVs and the ground control station caused by the obstacle blockage and the short communication range of economical wireless modules. The developed “Mom and Son” system is able to connect up to 13 UAV nodes [9]. A proof-of-concept two-UAV system was developed and tested that demonstrated the ability to relay radio communication between two or more UAVs. The quadrotor platform was first selected and the hardware of the communication relay system was constructed. Then a set of software programs and the protocol for autonomous mission control, communication relay control, and ground control were developed. Finally, the system was fully integrated into the airborne platform and tested in outdoor flight, shown in Fig. 4. The result shows the ability of the system to extend the communication range and build communication over obstacles. This FYP won the championship title of Innovation Design Category in the 2016 Taiwan Innovative Unmanned Aircraft Design Competition, organized by National Cheung Kung University (NCKU), Taiwan [8]. Also, this system was awarded the Gold Medal with the Congratulations of Jury at the 45th International Exhibition of Inventions of Geneva at Geneva, Switzerland from 29th Mar -2nd Apr 2017 [10] (Fig. 5). It is very possible that, under the complex environment of bridge inspection, the signal between the missioning UAV and the GCS signals may be weak or lost. This relay system can handle such problems and guarantee the inspector and pilot in the GCS to always monitor the UAV and the inspection process. One journal paper was published based on the outputs of this project [9].

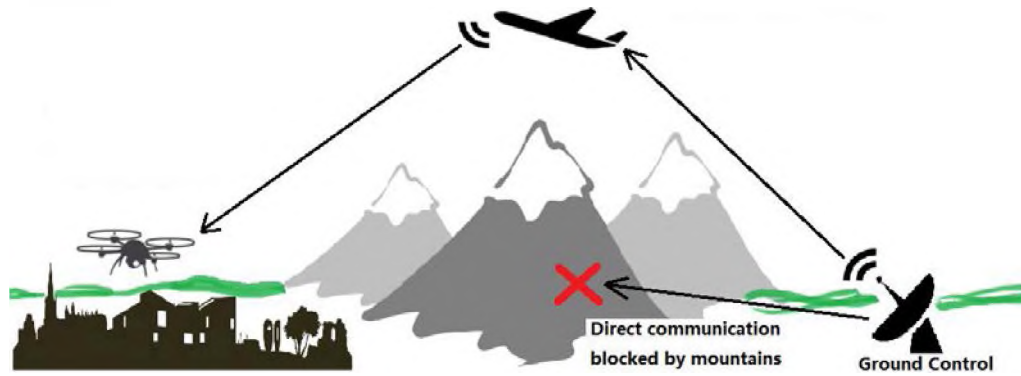

Fig.3. Application scenarios of UAV communication relay system

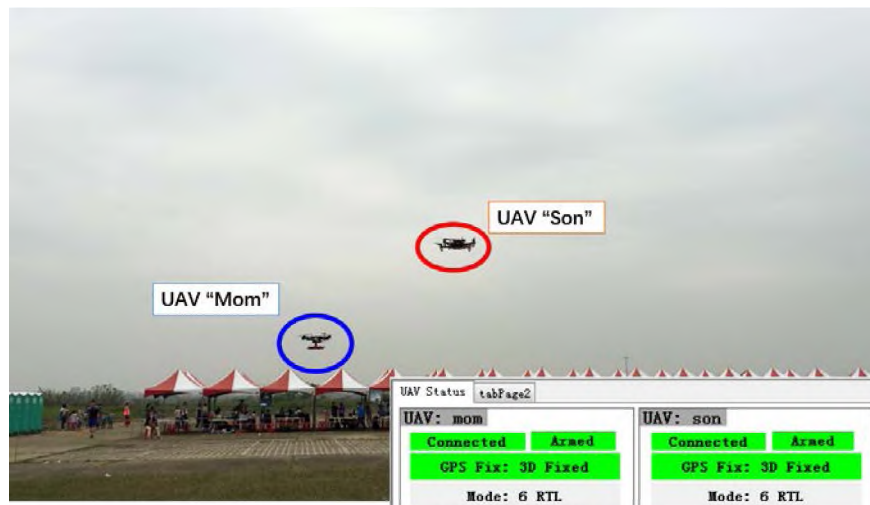

Fig.4. "Mom and Son" UAVs in the air



Fig.5. Gold award with the congratulations of the jury" (A+) in 45th International Exhibition of Invention of Geneva.

### 3. PUBLICATIONS AND ACHIEVEMENTS

In the past 6 years, the students were motivated to earn 11 awards, including 8 awards by FYP students. These FYP awards have generated enormous publicity in Hong Kong and Taiwan. Fig.6 shows some of the awards clinched in Taiwan Innovative Unmanned Aircraft

Vehicle (UAV) Design Competition. As mentioned above, in 2016, one FYP team won the Champion in the Innovation Design Category and another team won the champion in the Navigated Flight Category. This is the first time that Hong Kong teams won the championships in the similar international UAV competitions.

It is gratified that one journal paper [9] and one conference paper [11] were published by 4 FYP students and 10 FYP students continue to postgraduate studies in U.S., Switzerland, Canada, Taiwan, and Hong Kong.



Fig6. Awards in Taiwan Innovative Unmanned Aircraft Vehicle (UAV) Design Competition: *a*– Champion in Innovation Design Category, 2016; *b* – Champion in Navigation Category, 2016; *c* – First Runner Up in Navigation Category, 2017

With many efforts, our group has transferred the unmanned aerial vehicle technologies into the business through two start-up companies, “UAVI technology (Hong Kong) Limited” and “UAVI technology (Shenzhen) Limited”. These companies provide services to private or government sectors in both Hong Kong and Mainland China, about applying the UAV technologies to the practical ends and education uses. They are aiming to enlarge the UAV market but providing customized services, demonstrating the benefits of using UAVs compared to traditional methods. These FYP projects also nurtured entrepreneurship on campus.

#### 4. CONCLUSIONS

In this paper, the aircraft design education in the Department of Mechanical Engineering, The HK PolyU, was presented and discussed. The social structure and environment in Hong Kong resulted in a unique project-based aircraft design pedagogy instead of traditional lecturing one. The FYP becomes one of most important platforms to carry out the aircraft design education in UAV. With the attempt and exploration in past six years, remarkable outputs were achieved.

Based on the experience of the project-based aircraft design education in HK PolyU, one can notice that this pedagogy has its own advantages: (1) it can arouse the students’ interest in aircraft design and train the students’ capability of self-learning and problem solving; (2) By combining the FYP students with postgraduate students in the laboratory, the FYP students can be involved with research activities and be inspired by the post graduate students to pursue academic careers; (3) the students’ team work spirit can be nurtured; (4) By joining the external competitions, the students will learn how to well manage the timeline and budget and

become good engineers; etc. These advantages cannot be easily provided by another single course. However, some challenges have also been noticed when carried out this project-based aircraft design education. The supervisor has to design and update the project topics year by year, which requires energy and enormous time to supervise the students. From the view of the students, the workload of understanding and learning the previous outcomes keeps increasing for the series project like SAR UAV. In the cases of 2017 and 2018 SAR UAV projects, the students struggled to learn all the technologies that have been developed. This problem also raises the request for academic staff to handle the issues of technical documentation and knowledge transfer since the final year students graduated before the new FYP students started to get involved. To summarize, the project-based aircraft design education in HK PolyU is a successful example.

## REFERENCES

- [1] A. Zhang, "Analysis of an international air-cargo hub: the case of Hong Kong," *Journal of Air Transport Management*, vol. 9, no. 2, pp. 123-138, 2003/03/01/ 2003.
- [2] *Motto, Vision & Mission, The Hong Kong Polytechnic University*. Available: [https://www.polyu.edu.hk/web/sc/about\\_polyu/motto\\_vision\\_mission/index.html](https://www.polyu.edu.hk/web/sc/about_polyu/motto_vision_mission/index.html)
- [3] N. Michael, J. Fink, and V. Kumar, "Cooperative manipulation and transportation with aerial robots," *Autonomous Robots*, journal article vol. 30, no. 1, pp. 73-86, January 01 2011.
- [4] M. Polka, S. Ptak, and Ł. Kuziora, "The Use of UAV's for Search and Rescue Operations," *Procedia Engineering*, vol. 192, pp. 748-752, 2017/01/01/ 2017.
- [5] L. Meier, D. Honegger, and M. Pollefeys, "PX4: A node-based multithreaded open source robotics framework for deeply embedded platforms," in *2015 IEEE International Conference on Robotics and Automation (ICRA)*, Washington State Convention Center, WA, 2015, pp. 6235-6240: IEEE.
- [6] High-speed Thermo-fluid and MAV/UAV Laboratory (HTML). MAV/UAV, Available: <http://www.mypolyuweb.hk/cywen/research-area/mavuav.html>
- [7] J. Sun, B. Li, Y. Jiang, and C. Y. Wen, "A Camera-Based Target Detection and Positioning UAV System for Search and Rescue (SAR) Purposes," *Sensors (Basel)*, vol. 16, no. 11, Oct 25 2016.
- [8] 2016 Taiwan Innovative Unmanned Aircraft Design Competition. Available: <http://www.iaa.ncku.edu.tw/~whlai/uav/2016/index.html>
- [9] B. Li, Y. Jiang, J. Sun, L. Cai, and C. Y. Wen, "Development and Testing of a Two-UAV Communication Relay System," *Sensors (Basel)*, vol. 16, no. 10, Oct 13 2016.
- [10] Institute of Entrepreneurship. *The 45th International Exhibition of Inventions (Geneva)*, *The HK Polytechnic University*. Available: <https://www.polyu.edu.hk/ife/corp/en/innovation/award.php?awid=13587>



Wen Chih-Yung, Sun Jingxuan

[11] ZHANG Yiming, XU Weichen, CHEN Guangyi, “Design, Build and Test an Innovative Tail-Sitter Unmanned Aerial Vehicle (UAV),” in *International Conference on Reliability and Quality in Design*, Aug. 3-5, 2017, Chicago, U.S.A.

**Authors**



Wen Chih-yung



Sun Jingxuan

# AIRCRAFT USING GROUND EFFECT: HISTORY, FEATURES, EFFICIENCY ESTIMATION AND PROSPECT OF DEVELOPMENT

Victor Morozov<sup>1</sup>, Enoch Ahiagbedey<sup>2</sup>

1 – “Aerorick” Enterprise, Ltd, Nizhny Novgorod, Russia

2 – Nanjing University of Astronautics and Aeronautics, College of Aerospace Engineering, 29 Yudao St., Nanjing 210016, P.R. China

**Key words:** ground effect, ekranoplan, geometric chord of wing, focus

**Abstract:** *This article is based a research on aircraft using ground effect; mainly the soviet ekranoplan. It also gives some information on the history, features, efficiency estimation and the prospect of development.*

## 1. Introduction

A ground effect vehicle (GEV) is one that attains level flight near the surface of the Earth, made possible by a cushion of high-pressure air created by the aerodynamic interaction between the wings and the surface known as ground effect. Also known as a wing-in-ground-effect (WIG) vehicle, flare craft, sea skimmer, ekranoplan, or wing-in-surface-effect ship (WISE), a GEV can be seen as a transition between a hovercraft and an aircraft. The International Maritime Organization (IMO), has classified the GEV as a ship. A GEV differs from an aircraft in that it cannot operate without ground effect, so its operating height is limited relative to its wingspan.

In recent years a large number of different GEV types have evolved for both civilian and military use. However, these craft are not in wide use. And the greatest attract attention to themselves so-called ekranoplans [1-8].

## 2. History

Small numbers of experimental vehicles were built in Scandinavia just before World War II. By the 1960s, the technology started to improve, in large part due to the contributions of the Soviet Rostislav Alexeyev and German Alexander Lippisch. They independently worked on GEV technology, arriving at very different solutions.

The main merit in the creation of ekranoplans belongs Rostislav Alexeyev (1916-1980). R. Alexeyev initially served as a foreman for tank production, but in 1942 was reallocated by the Soviet Navy to developing hydrofoils for combat use. His designs were not completed by the end of the war in 1945, but the Soviet government maintained interest in them and 340 hydrofoil vessels had been planned by the late 1940s. Alexeyev continued working on hydrofoils and became chief designer of the Raketa, the first passenger hydrofoil commercially produced in the Soviet Union, which began production in 1957. The Raketa was presented at the International Festival of Youth and Students in Moscow that year, and interest in hydrofoils grew even further. Alexeyev was chief designer for numerous passenger

Victor Morozov, Enoch Ahiagbedey

hydrofoil designs produced at Red Sormovo, including the Meteor, the Kometa, the Sputnik, the Burevestnik, and others.

In 1962, Alexeyev began working at the Central Hydrofoil Design Bureau (TsKB SPK) which specialized in the secret development of ground effect vehicles, named ekranoplans. In the 1950s the Soviet Union saw a great interest in ground effect vehicles, which at the time were largely ignored by the rest of the world, and had been developing them at a rapid pace. Ground effect vehicles were technically aircraft, but operated using ground effect to travel only several meters above flatter surfaces, particularly bodies of water, leading them to be classified as ships by the Soviet government. The TsKB SPK planned a massive ekranoplan utilizing the "Wing in Ground" (WIG) effect, and Alexeyev was invited to participate in development due to his expertise with hydrofoils. Only two years after development began the project resulted in the Korabl Maket (KM), better known in English as the Caspian Sea Monster – Fig.1.



Fig 1. Caspian Sea Monster

These craft were originally developed by the Soviet Union as very high-speed military transports, and were based mostly on the shores of the Caspian Sea and Black Sea. The largest had a max take-off weight of over 544 tons, eight were built. Although designed to travel a maximum of three meters above the sea it was found to be most efficient at 20 meters reaching a top speed of 300 Knots (400 knots in research flight).

The Russian Ekranoplan program continued and led to the most successful ekranoplan so far, the 125-ton A-90 Orlyonok – Fig.2.



Fig 2. Orlyonok A-90

GEV developed since the 1980s have been primarily smaller craft designed for the recreational and civilian ferry markets. Germany, Russia, and the US have provided most of the momentum with some development in Australia, China, Japan, and Taiwan. In these countries, small craft up to ten seats have been designed and built. Other larger designs as ferries and heavy transports have been proposed, though none have gone on to further development.

In Germany, Lippisch was asked to build a very fast boat for Mr. Collins from Collins Radio Company in the USA. He developed the X-112 – Fig.3, a revolutionary design with reversed delta wing and T-tail. This design proved to be stable and efficient in ground effect and even though it was successfully tested, Collins decided to stop the project and sold the patents to a German company called Rhein Flugzeugbau (RFB) which further developed the model.



Fig 3. The experimental two seat ground effect vehicle X-112

### 3. Design

The Ground Effect or sometime use a term the Screen Effect, all other things being equal, allows to reduce the required cruising power of the engines. The parameter characterizing the altitude of the ekranoplan (Fig.4) take the ratio of the altitude ( $h$ ) to the mean aerodynamic chord of the wing ( $b_{MAC}$ )

$$\bar{h} = h/b_{MAC} \quad (1)$$

In some sources, the relative altitude is determined by the formula

$$\bar{h} = h/S^{1/2} \quad (2)$$

where  $S$  is the area of the wing planform.

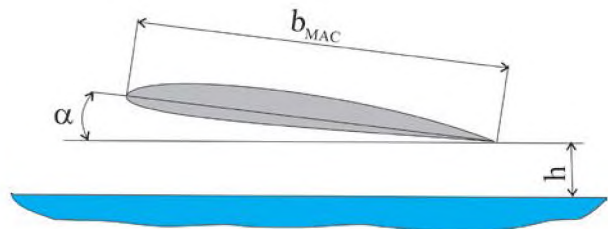

Fig 4. The estimation of the altitude of the ekranoplan flight

#### 4.1 Aerodynamic features of the ekranoplan

The effect of the screen is manifested at low altitudes (Fig.5 – [2]). In cruising, the effect of the screen with a decrease in the relative height is reduced to an increase in the angle of inclination of the curves  $C_L=f(\alpha)$ .

The following features can be noted:

1. The effect of the screen practically does not increase the value of lift coefficient  $C_{Lmax}$ .
2. With decreasing  $\bar{h}$  decreases the angle of stall (the critical angle)  $-\alpha_{cr}$ .
3. When increasing the speed of flight can be achieved  $C_L^*$ , in which the effect of the screen will be zero. And below the  $C_L^*$  value, the screen effect will be negative.
4. With an increase in the flight speed of the ekranoplan and, accordingly, a decrease  $C_L$ , the absolute increase in the lifting force  $\Delta C_L$  when approaching the screen decreases, and the damping properties of the wing decrease with sudden gusts of wind.
5. With decreasing  $\bar{h}$  and increasing angle of attack (increasing  $C_L$ ) derivative  $C_L^{\alpha}$  is decreasing (decreases the slope of the curve  $C_L=f(\alpha)$  in its upper part).

Together, these features mean that the effect of the screen will appear in a rather narrow "corridor" angles of attack. Important when choosing the wing shape is the aspect ratio of the wing  $\lambda=l^2/S$ . The dependence (growth) of aerodynamic quality  $K=L/D=C_L/C_D$  (or  $L/D$  ratio) with the approach to the screen changes significantly with a large  $\lambda$  and is weaker with a small one (Fig.6, [6]). The intensive growth of aerodynamic quality continues to  $\lambda=3$ , with a further increase in  $\lambda$ , the increase in aerodynamic quality reaches its limit (Fig.7).

It should be noted that with increasing  $\lambda$  decreases shift in the tail of the wing and the focus height and focus angle of attack. In this case, the value of the offset for the rectangular wing at the focus height is greater than that of the focus at the angle of attack.

For modern transport aircraft, as well as seaplanes, rational elongation is in the range from 7 to 12, for maneuverable military aircraft from 3 to 6. This value is the result of an unprecedented amount of experimental and scientific research.

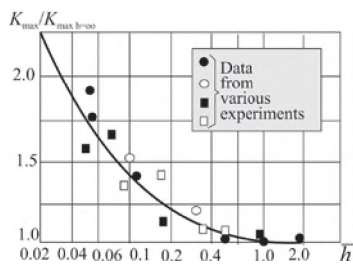

Fig. 5. Changing the aerodynamic quality ( $L/D$ ) of the wing depending on the relative altitude

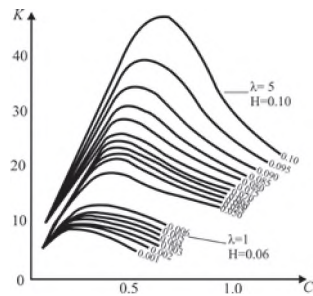

Fig 6. Dependence  $K$  on  $\lambda$  of the wing and  $\bar{h}$  in the Function  $C_L=f(\alpha)$

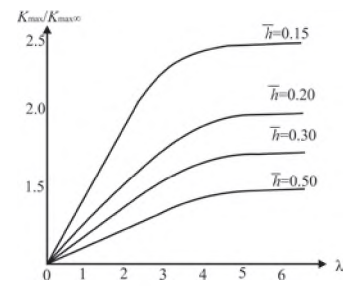

Fig 7. The change in the function  $K_{max}/K_{max \infty}=f(\bar{h}, \lambda)$

The increasing of  $\lambda$  leads to:

- increased influence of screen effect, and the earlier its manifestation at large relative heights;
- with equal aerodynamic quality reduction of the absolute height of the flight compared to ekranoplans with a small extension of the wing;
- a significant increase in aerodynamic loads on the wing, (according to the theory of the wing, the load is proportional to the cube of the wing extension);

- a significant increase in hydrodynamic loads on the wing as a whole, and flaps in particular, on takeoff and landing modes;
- significant increase in wing weight compared to the wing of the seaplane;
- increased risk of exchange rate instability during takeoff and landing, and increased probability of burying the console in water;
- reduction of the lifting force of the blower, (the work on the analysis of the blower is completed)
- a significant increase in the resistance boost,
- the complexity of the issues maneuvering and disagreements with the courts and other constraints on the route in the cramped waters of the port or rivers.

A new direction in the last works of the outstanding designer, R. E. Alekseev was the creation of passenger ekranoplans with an elongation of about  $\lambda=1.0 -1.5$ . Despite the fact that this trend does not give high quality screen flight, it deserves careful studying and, probably, requires specification, and maybe change of optimization criteria. According to the criterion of Irodov, an ekranoplan is statically stable in flight screen play subject to the terms;

$$\bar{X}_{F\alpha} - \bar{X}_{Fh} > 0 \quad (4)$$

$$\bar{X}_{F\alpha} - \bar{X}_T > 0 \quad (5)$$

where  $\bar{X}_T$ ,  $\bar{X}_{F\alpha}$ ,  $\bar{X}_{Fh}$  are the relative position of center of gravity, of the focus in angle of attack and of altitude.

For an isolated wing at the approach to the screen all the focus when you reduce  $\bar{h}$  and the increase in  $\alpha$  are shifting to the back, the amount of displacement of focus height greater than the focus on the angle of attack. Since usually a rectangular wing

$$X_{F\alpha} - \bar{X}_{Fh} < 0 \quad (6)$$

it requires a fairly large area of horizontal tail (HT), located in the tail of the fuselage. In order to reduce the impact of the screen, the plumage is placed on a significant excess over the wing, usually on the top of the keel. The relative area of the tail in modern wig often reaches 30-45 % of the area of the wing.

The power of HT is usually determined by the static moment of the horizontal tail

$$A_{HT} = S_{HT} \times L_{HT} / (b_{mac} \times S) \quad (7)$$

where  $S_{HT}$  is an area of the HT,  $L_{HT}$  is the shoulder from the center of mass to center of pressure,  $b_{mac}$  is the mean aerodynamic chord of the wing.

For transport aircraft  $A_{HT} = 0.8-1.0$ , passenger aircraft much less. Ekranoplans of the first generation had by 30-50 % more than the  $A_{HT}$  transport aircraft. It should be noted that amphibious ekranoplans of the "Rocket-2" type have a static moment of  $A_{HT} \leq 0.2$ , which can be explained by the influence of the s-shaped profile of the wing.

Since the focus height is not dependent on the horizontal tail, the airfoil has a pretty big aft alignment, usually  $\bar{X}_T \approx 0.32 - 0.38$ , and in some cases it can be more. It is recommended to choose the Center of Gravity (CG) near the focus height and strictly control the run of the CG. For example, for this purpose in the ekranoplan "Aqua glide" were provided loads of variable and constant components of the balancing ballast.

#### 4.2 About takeoff and landing device

The most important issue in the formation of the concept of ekranoplan is the choice of the type of takeoff and landing device (TLD). The best option is to provide amphibious basing. Only two types of TLD can ensure this:

- air-cushion chassis (ACC) and its type – blower;
- additional wheel chassis (AWC).

Additional wheel chassis allows you to go ashore on a concrete slip, so it is formally provided amphibious (two-medium) basing, but does not provide without airfield basing. On the other hand, the airbag and the airbag do not provide amphibious basing without flexible airbag chamber barriers. In TsKB SPK developed the concept of planning pneumatic balloons, which sharply expanded the possibilities of wig in the basement. The ability of passenger ekranoplans to go ashore and receive passengers without special slips, to work in conditions of elementary coastal infrastructure is a powerful incentive for the development of high-speed transport on the main rivers.

## 5. Efficiency Estimation

When analyzing the economic efficiency of ekranoplans, we proceed from the generally recognized fact that ekranoplan is primarily an aircraft, the effectiveness of which should be evaluated from the standpoint of aircraft construction criteria. It is known that the efficiency of transport vehicles is estimated by comparing the beneficial effect with its costs. According to the classification, taken by us from the work and supplemented with respect to ekranoplan, economic efficiency consists of three components: transport, production and operational efficiency.

**Transport efficiency** reflects only that side of perfection of the ekranoplan which depends on its technical indicators, such as weight return, aerodynamic and hydrodynamic quality, specific fuel consumption. These indicators will be discussed later.

**The production efficiency** of the ekranoplan reflects its perfection in terms of industrial production. It is determined by such private criteria such as manufacturability, interchangeability, the level of normalization, the development of new materials and technical processes, etc. we will remind that under the production technology necessary to understand the complex properties of the design of the ekranoplan allows you to apply for its manufacturing processes, ensuring high quality with minimal labor and minimal cost. Production manufacturability wig implies a reasonable division of FV on aggregates, coming then to the General Assembly of the airframe. The key objective of the production technology is to achieve the lowest possible cost of the design of the ekranoplan that meets the regulatory requirements (Aviation rules and rules of the River register). The construction cost of the wig obviously consists of the cost of the airframe and the cost of components, including propulsion. It seems obvious that for a relatively low-speed ekranoplan flying at low altitudes does not require less technological round shape of the fuselage, which makes it possible to reduce the cost of technological equipment and the widespread use of panel Assembly method. To a significant reduction in the construction cost of the wing structure can lead to the use of a straight wing without a loan. Minimizing the power of the power plant is also one of the ways to reduce the construction cost.

**Operational efficiency** of ekranoplan reflects its perfection as an object of technical operation. It depends on such features as durability, reliability under specified operating conditions, operational manufacturability (simplicity and ease of maintenance without additional airfield support at low cost of time and money), the possibility of access to elementary equipped coastal areas for receiving and changing passengers, refueling, maintenance. For river ekranoplan the most important indicator of operational efficiency is its year-round regular use, including periods of melting and ice formation on rivers.

## 6. Comparison

The ekranoplan, as the aircraft is similar in purpose and design to the hydrofoil. Therefore, has the following structural takeoff weight

$$m_0 = m_d + m_e + m_{e\&c} + m_f + m_{ul} + m_{sl} \quad (8)$$

where  $m_d$  is the mass airframe design,  $m_e$  is the mass of the power plant,  $m_{e\&c}$  is the mass of equipment and control system,  $m_f$  is the fuel mass,  $m_{ul}$  is mass of useful (targeted) load,  $m_{sl}$  – the mass of the service load.

In the aircraft industry for a comparative assessment of the mass of the components of the takeoff weight using the relative weight by dividing both sides of equation (8) on  $m_0$ . The resulting expression is called the weight balance equation in relative values.

$$1 = \bar{m}_d + \bar{m}_e + \bar{m}_{e\&c} + \bar{m}_f + \bar{m}_{ul} + \bar{m}_{sl} \quad (9)$$

The approximate distribution of the relative masses of different aircraft by weight cost items is shown in table 1. Information on weight statistical data of ekranoplans is extremely limited. This is an important point, as the majority of designers of screen planes, built in the post-Soviet period, give only advertising characteristics, unfortunately, often far from the true values. In this table we relied on published statistics and calculated using standard aviation techniques.

Table 1. The relative masses of the structure, power plant, equipment and control, fuel and payload (in fractions of the take-off weight)

Type of Flight Vehicle	$\bar{m}_d$	$\bar{m}_e$	$\bar{m}_{e\&c} +$	$\bar{m}_f$	$\bar{m}_{ul}$
Subsonic passenger aircraft	0.28-0.30	0.10-0.12	0.10-0.12	0.26-0.30	0.20-0.26
Light seaplanes	0.34-0.38	0.12-0.15	0.12-0.15	0.10-0.20	–
Medium Seaplane (Be-6)	0.46*	0.213	–	0.13	0.18***
Light aircraft with ball screw ("Dingo")	0.310	0.19	0.109**	0.162	0.232***
Transport aircraft	0.26-0.28	0.10-0.12	0.12-0,14	0.25-0.30	0.20- 0.27
Ekranoplan "LUN"	0.44*	0.12	–	0.158	0.264***
Ekranoplan "Volga-2"	0.328	0.245	0.105**	0.068	0.258***
Ekranoplan RT-6 (Kazan)	0.452*	0.17	–	0.095	0.252***
Ekranoplan "Oriole-2" EC-12	0.369*	0.272	–	0.069	0.290***

\*- including systems and equipment without Control System (CS),

\*\*- including pneumatic chassis.

\*\*\* - payload enabled service (crew)

These weight characteristics confirm the obvious fact that the relative masses of the airframe and power plant design are close to seaplanes. It should be borne in mind that the hydraulic plane Be-6 installed piston engines with high specific gravity. Installing it on the turboprop engines would reduce the relative weight of the  $\bar{m}_e$  by half. The relative weight of the empty ekranoplan is in the range of 56-68 % of the take-off weight, which is significantly higher than the relative weight of the empty subsonic passenger aircraft with a relative weight of the empty aircraft 45-50 %. Draws attention to the high relative mass of the empty FV "Volga-2". This is explained by the large weight of the power plant design and, in particular, the "Volga-2" engine (a screw in the ring with a long shaft and a deflector grid on the cut of the ring). Nevertheless, this system proved to be very successful both for increasing the efficiency of the boost and the cruising regime with extremely low energy intensity (this will be discussed below). It is important to note that the mass of the airframe at "Volga-2" (without the  $\bar{m}_e$ ), a record low for the ekranoplanes.



Table 2. Ekranoplan Ivolga-2 (EK-12) in comparison with other AIRCRAFT

Parameter / FV	Ivolga -2 EK-12	Cessna 208 Caravan	Pilatus PC6 Turbo-Porter	Plane ACC Dingo
Length, m	15	11.46	10.9	12.5
Wing span, m	12.5	15.86	15.87	14.5
Wing area, m <sup>2</sup>	≥ 50 +	25.96	28.8	26
Takeoff weight, kg	3900	3629	2770	3700
Empty weight, kg	2430*	1752	1270	2250
Payload weight kg	1200		1130	850
Fuel weight, kg	270		370	600
The capacity: the crew/passengers	2/12**	1/9	1/10	1/8
Power plant	2 PD-LC3	1 Turboprop	1 Turboprop	1 Turboprop
Power, hp	2 x 430	503	550	1100/200
Maximum speed. km/h	220	352	255	350
Cruising speed, km/h	185	341	215	275
Range, km	1300	1050	1400	1797
Seaworthiness ( $h_{V-3\%}$ ), m	1.25			0.35

### 7. About prospects of the ekranoplans development

In our opinion an ekranoplan should be amphibious, simple in design, reliable, safe, technological, with low construction cost (but not due to primitive conditions of creation), convenient and inexpensive to maintain. River ekranoplan should be as close as possible to the aircraft on the mass' efficiency and have extremely low cruising power to maintain fuel efficiency.

Classical aerodynamic configuration with straight wings of small aspect ratio (about 1), and the high-set horizontal tail.

Low specific load on the wing, providing cruising at speeds up to 200 km/h.

Two turbofan engines located in the nose are used for both cruising flight and to create the air cushion by a blower - the direction of flow from the propellers under the wing to create lift under the wing. One theater is located on the keel in the tail section and serves only for marching cruising – Fig.8, *a*. Other options are not excluded – Fig.8, *b*.

*a**b*

Fig.8. Possible types of river amphibious ekranoplan

Amphibious chassis; which includes two wings and one central pneumatic balloons. They play the role of flexible side fencing area of air cushion generated by the spiral blowing under the wing. The role of the aft fence of the air cushion is played by rigid flaps of the wing of the ekranoplan.

## 8. Conclusion

In General, the following conclusions can be drawn.

1. The relative weight of the airframe of the ekranoplan is higher the same characteristic of the ground one and close to the corresponding parameter of the seaplane, and sometimes surpasses it.
2. The greatest "screen effect", in which the aerodynamic quality of the wing is significantly increased, is achieved at  $\bar{h} < 0.1$ .
3. The loads for the ekranoplan are determined in different modes of movement, from cruising to landing and swimming. The main calculated cases are the take-off and landing modes in the conditions of a given maximum excitement of water surface.
4. The determining loads ekranoplan, which in principle form the weight gain of the airframe in comparison with the land plane, are hydrodynamic loads.
5. The ekranoplan receives greater shock loads on the glider than a seaplane at a significantly higher speed of the latter's cruising flight.
6. Despite the large hydrodynamic load on the wing, wing mass increases not so much. This is primarily due to the fact that the main wing is calculated according to the norms of the strength of the aircraft and a key factor in determining the mass of the wing is the bending moment, which is proportional  $\lambda^3$ , i.e. it decreases in proportion to the cube of the lengthening of the wing. In this connection the aspect ratio for ekranoplans is relatively low.
7. Attributed to the exceptional properties of ekranoplans, including high aerodynamic quality and a significant weight return, superior to the return of land aircraft, have no practical confirmation. Performance of land-based aircraft is always higher performance with wig equal to the target load.
8. Comparison of ekranoplanes and aircraft at the cost of flight hours when flying at the estimated range without intermediate landings shows the full advantage of the aircraft. With a high probability for passenger ekranoplanes there is a rational area of application on large main rivers, subject to year-round use and the possibility of access to the shore areas for disembarkation and reception of passengers. Herewith the more intermediate landings along the route, the more obvious will be the economic advantage of ekranoplan over aircraft and seaplanes.
9. The expediency of the year-round use of amphibious ekranoplanes will be the higher the hydrodynamic perfection of the ekranoplan and the smaller the difference between the take-off and cruising power of the main engines. To a large extent, this corresponds to the air cushion chassis with a flexible railing of the aircraft with air-cushion sassy.

## REFERENCES

- [1] V.Morozov. The Choice of the Design Parameters of Ekranoplans. Textbook. Nizhny Novgorod. 2003. 39p. (In Russian)
- [2] Belavin N. And. Ekranoplans. L.: Sudostroenie. 1977. 232 p. (In Russian)
- [3] Maskalik A.I., Kolyshev B.A., Zhukov V.I., and others. Ekranoplans. Features of the theory and design. Sudostroenie, 2000, 320 p. (In Russian)

[4] Technical information TSAGI. Series: aviation and missile technology. Ekranoplans. Issue 4-5. 2011. 79 p. (In Russian)

[5] Kulbida V. E., Morozov V. P., Transport efficiency of aircraft without Aerodrome based, Moscow. NIA-Priroda, 2003. 220 p. (In Russian)

[6] Musatov R. A.. Features of the influence of elongation of the rectangular wings on the aerodynamic characteristics close to the screen. Collection of reports of the 1st scientific conference on hydroaviation "Hydroaviasalon-2002"., 2002 Moscow. TSAGI. 2002, p. 273-280. (In Russian)

[7] [https://en.wikipedia.org/wiki/Ground-effect\\_vehicle#History](https://en.wikipedia.org/wiki/Ground-effect_vehicle#History)

[8] [https://en.wikipedia.org/wiki/Ground-effect\\_vehicle#Ekranoplan\\_wing](https://en.wikipedia.org/wiki/Ground-effect_vehicle#Ekranoplan_wing)

[9] <https://worldview.stratfor.com/article/ground-effect-vehicles-adopting-orphaned-technology>

[10] <https://www.youtube.com/watch?v=VyNAkfuNS5U>

[11] <https://www.youtube.com/watch?v=Z1ApOI-nB9Y>

[12] <https://www.sciencedirect.com/science/article/pii/S0376042106000637>

### Authors



Victor Morozov



Enoch Ahiagbedey

## OPTIMIZATION OF STRUCTURES BY STIFFNESS CRITERION

Pavel Shataev<sup>1</sup>, Samuel E. Nana Agyeman<sup>2</sup>

1 – Kazan National Research Technical University named after A. N. Tupolev – KAI

No.10, K.Marx St., Kazan, 420111, Russia

e-mail: [pashataev@vandex.ru](mailto:pashataev@vandex.ru)

2 – Nanjing University of Astronautics and Aeronautics,

29 Yudao St., Nanjing 210016, P.R.China

e-mail: [nanakwasiinr@outlook.com](mailto:nanakwasiinr@outlook.com)

**Key words:** thin-walled structure, stress-strain state, stiffness, optimization, heating, temperature and creep deformation, finite element method

**Abstract.** *The problem of obtaining the most rigid thin-walled unevenly heated structure with a given mass and with a given load-carrying scheme is considered. Also taken into account are possible deformations of plasticity and creep, often accompanying work at high temperatures. The optimization of the design is carried out on the basis of the criterion method of maximum rigidity. The criterion for obtaining the maximum rigidity of the structure is made taking into account the initial deformations and dissimilar materials. Numerical studies have been carried out.*

### 1. INTRODUCTION

The one of the most important parameters of the aircraft design is stiffness. The concept of "stiffness" is quite broad, but if we talk about the quantitative assessment, it is determined by deformations or their integral characteristics in the form of generalized displacements (deflections, twisting angles) in certain sections or points. Very often in power design, stiffness can be a determining factor, for example: for structures of large elongation (Fig.1); due to the development of such physically-nonlinear factors as plasticity, creep, taking place at a high level of heating and in a number of other project situations.

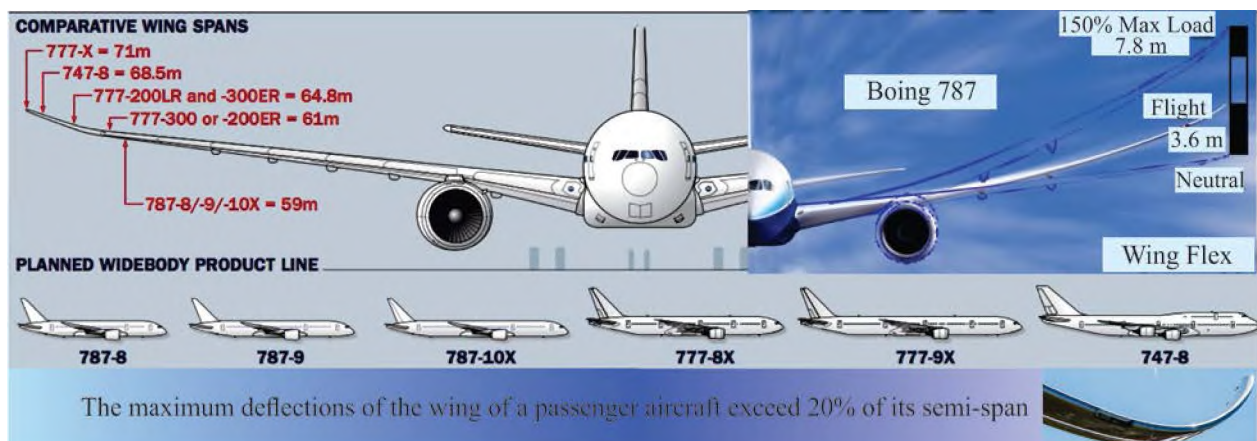

Fig.1. Deflections of the wing of a passenger aircraft

The design of the most rigid structure has always remained and will always remain an urgent problem in the creation of thin-walled structures of aircraft.

## 2. MAIN PART

Created numerical methods, combined with the infinitely increasing computing capabilities of modern computers, have made a real revolution in the development of any technology, and especially associated with high-tech and high-precision technologies, including in the design of aircraft. In solving problems related to the assessment of stress-strain state (SSS), the finite element method (FEM) is most often used in the variant in which nodal displacements are the desired ones, and a system of algebraic equations of the form is solved to find them

$$Kv=P \quad (1)$$

where  $K$  is the stiffness matrix;  $v$  and  $P$  are the vectors of displacements and given loads at the nodal points of the computational model of the considered construction.

In the derivation of expression (1), and in general in solid mechanics, for any calculations on strength and rigidity, the design of the power structures invariably used the Hooke's law. In accordance with this law, discovered by Robert Hooke in 1660, the deformation occurring in the elastic body is proportional to the force applied to the body.

In the General form the Hooke's law is the linear relationship between the tensors of stress and strain as  $\sigma=C\varepsilon$  or  $\varepsilon=D\sigma$  where  $\sigma$ ,  $\varepsilon$  are the tensors of stress and deformation of the second rank,  $C$  and  $D$  are the tensors of elasticity (stiffness) and elastic compliance of the fourth grade.

In engineering calculations for a linearly elastic isotropic body, Hooke's law in the Cartesian coordinate system is usually written in the traditional form

$$\varepsilon_x=\sigma_x/E-\mu\sigma_y/E-\mu\sigma_z/E; \varepsilon_y=\sigma_y/E-\mu\sigma_x/E-\mu\sigma_z/E; \varepsilon_z=\sigma_z/E-\mu\sigma_x/E-\mu\sigma_y/E; \quad (2)$$

$$\gamma_{xy}=\tau_{xy}/G; \gamma_{yz}=\tau_{yz}/G; \gamma_{xz}=\tau_{xz}/G$$

where  $\varepsilon$  and  $\sigma$  are normal strains and stresses on the respective coordinate axes;  $\gamma$ ,  $\tau$  are shear strain and stress,  $E$  is young's modulus,  $\mu$  is the Poisson's ratio,  $G=^{1/2}E/(1+\mu)$  is the shear modulus.

Let's focus on the problem of designing thin-walled structures of the aircraft, such as the aerodynamic surfaces (wing, tail, steering surface) or the aircraft body (fuselage, nacelles, fairings, etc.). For the analysis of SSS such structures are most often used finite elements of two types: one-dimensional elements that simulate the operation of stringers, caps of spars and ribs (Fig.2) and two-dimensional membrane type for skin and walls (Fig.3). With such finite elements (FE) it is possible to simulate the operation of most aircraft thin-walled structures. Their use allows to carry out with sufficient accuracy both structural, and parametric design, especially at initial stages of design. In the first case, the most rational scheme of structure is being found (location and relationship of load-carrying elements – the topology of the structure). In the second case, within the framework of the already selected structure, the optimal values of the parameters of the load-carrying elements are being found.

FE schemes, expressions (2) in the local coordinate system and accepted designations of the parameters, which within the FE will be considered constant, are presented in the table. 1.

Table 1

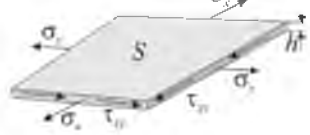
Used finite elements for suggested model		
FE type	One-dimensional (rods)	Two-dimensional (membranes)
Scheme	 Fig.2	 Fig.3
Hooke's law	$\epsilon_x = \sigma_x / E$ (3)	$\epsilon_x = \sigma_x / E - \mu \sigma_y / E$ $\epsilon_y = \sigma_y / E - \mu \sigma_x / E$ (4) $\gamma_{xy} = \tau_{xy} / G$
Design parameters for structural design	Length – $S$ Sectional area – $h$	The element area in plan – $S$ The thickness of the element – $h$
Design parameters for parametric design	Sectional area – $h$	The thickness of the element – $h$

For the unification of formulas the specifying design parameters of both types of FE are marked the same –  $h_i$ . For one-dimensional FE  $h_i$  is the cross-sectional area of the rod, for two-dimensional – it is the thickness of the element. Structural parameters  $S_i$  (in this formulation of the problem they are considered to be given) are: in the first case, the length of the element; in the second – the area of the element in the plan. In both cases, the FE volume FE is calculated the same  $V_i = S_i h_i$ .

For constructions working in conditions of heating, in design calculations, as a rule, the vector of total strains  $\epsilon$ , in addition to an elastic component  $\epsilon_e$ , also contains the initial deformation  $\epsilon_e$ . For element  $i$ -th

$$\epsilon_i = \epsilon_{e_i} + \Delta \epsilon_i . \tag{5}$$

The appearance of initial strains in this formulation may be due to temperature deformations ( $\epsilon_{T_i}$ ), and in the case of the calculation in terms of a physically nonlinear factors, with the deformation plasticity ( $\epsilon_{p_i}$ ) and creep ( $\epsilon_{c_i}$ ), thus

$$\Delta \epsilon_i = \epsilon_{T_i} + \epsilon_{p_i} + \epsilon_{c_i} . \tag{6}$$

Traditionally, to solve the problem with initial deformations, the method of fictitious loads is usually used, according to which the system of equations (1) is converted to the form

$$Kv = P + \Delta P, \tag{7}$$

where  $\Delta P$  is the vector of additional loads, which provides the elements of an appropriate initial deformation  $\Delta \epsilon_i$ .

For the evaluation of thermal deformation according to the hypothesis of the Duhamel-Neumann enough knowledge of the temperature and linear expansion coefficient of the material. To simplify the problem, we assume that the stress and strain field within the FE is constant, which implies a linear law of displacement changes, as well as perform averaging of temperature deformations. Then the vector of temperature deformations for the membrane isotropic  $i$ -th element

$$\boldsymbol{\varepsilon}_T = \left\{ \sum_{j=1}^m \frac{\alpha_{T_i} T_{ij}}{m} \quad \sum_{j=1}^m \frac{\alpha_{T_i} T_{ij}}{m} \quad 0 \right\}, \quad (8)$$

where  $m$  is the number of nodes in the FE,  $\alpha_i$  is the coefficient of linear thermal expansion of the material of the element,  $T_{ij}$  is the additional temperature in the node  $j$ -th of the element  $i$ -th (compared to the temperature during assembly).

For one-dimensional KES, the temperature strain vector is a scalar quantity

$$\varepsilon_{T_i} = \frac{1}{2} \sum_{j=1}^2 \alpha_{T_i} T_{ij}. \quad (9)$$

Averaging in (8-9) can be interpreted as a single point numerical integration.

We introduce the notion of pseudoelasticity. For this purpose it is assumed that the total deformations in the element are elastic and obey the Hooke's law. On the example of a one-dimensional element, it will look like this

$$\varepsilon_i = \sigma_i / E_i + \Delta \varepsilon_i = \sigma_i / e_i, \quad (10)$$

where  $e_i$  is the introduced conditional elasticity modulus, which we call pseudo-elasticity modulus. It follows from (10) that

$$e_i = E_i (\varepsilon_i - \Delta \varepsilon_i) / \varepsilon_i = E_i k_i, \quad (11)$$

where  $k_i$  is the coefficient of pseudoelasticity, which corrects the real modulus of elasticity  $E_i$  depending on the initial deformations, the load level and the degree of deformation constraint FE in interaction with other elements

$$k_i = (\varepsilon_i - \Delta \varepsilon_i) / \varepsilon_i = \varepsilon_{el} / \varepsilon_i. \quad (12)$$

In the absence of initial deformations  $k_i = 1$ . In General, this coefficient can range from  $-\infty$  to  $+\infty$ . The values  $k_i$  are shown in Tabl.2 on the example of one heated or, conversely, cooled rod with different fixing conditions..

Table 2

The coefficient of pseudelasticity depending on the fixation and heating of the rod

No	The scheme of fixing and heating	The stress-strain diagram	$k$
1			$-\infty$
2			0
3			$+\infty$

Fig.3 provides a geometric interpretation of the modulus of pseudoelasticity on the stress-strain diagram for heated and loaded rod, where  $\beta$  is the inverse tangent of  $e$ . There are two interpretations of heating and loading: 1<sup>st</sup> – the element is first heated, and then loaded with a force that grows from zero to the final value; 2<sup>nd</sup> – the element is first heated, and then loaded.

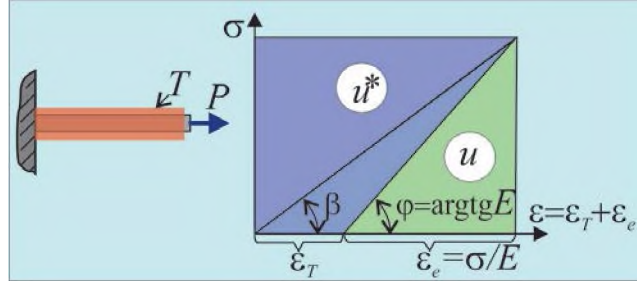

Fig.3. The physical meaning of the pseudoelasticity module for the case of "heating, then loading the rod", where  $u$  is the specific potential energy of elastic deformations (PED),  $u^*$  is the specific additional PED

To assess the effect of constraint, consider the interaction of two elements shown in Fig.4,  $a$ . These elements can be to represent a fragment of the structure, including the skin and stringer, the cover and the cap of the spar or rib, etc. In this case, the first element is a strip that works without loss of stability on stretching-compression with the second element. Both elements are modeled by rods working according to the scheme shown in Fig.4,  $b$ . Such a fairly simple model makes it possible to understand the local effects in the heated structure quite simply [1].

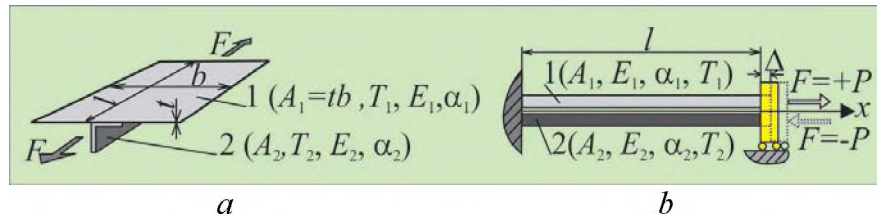

Fig.4. A fragment of the structure ( $a$ ) and its design model ( $b$ ), consisting of two rod elements loaded with longitudinal force and having a different temperature

To simplify the calculated ratios, let us assume that  $T_2=0$ .

The 1<sup>st</sup> case. Consider the operation of the rods only from the temperature load, and the longitudinal force  $P=0$ . From the condition of equality of total deformation  $\epsilon_1=\epsilon_2=\epsilon$  and equilibrium conditions  $A_1\sigma_1+A_2\sigma_2=0$ , we obtain the ratio:

$$\epsilon=\alpha_1 T_1 E_1 A_1/\Sigma E_i A_i, \quad \sigma_1=E_1(\epsilon-\alpha_1 T_1 E_1), \quad \sigma_2=E_2\epsilon.$$

The expression for the modulus of pseudoelasticity of first rod

$$e_1=-E_2 A_2/A_1. \quad (13)$$

The corresponding coefficient of pseudoelasticity

$$k_1=-E_2 A_2/(E_1 A_1). \quad (14)$$

As can be seen for this problem,  $e$  and  $k$  do not depend explicitly on temperature, but only on the stiffnesses ratio.

The 2<sup>nd</sup> case (the longitudinal force and temperature effects on the first rod) – the module  $e_1$  and the first rod pseudoelasticity coefficient

$$e_1=E_1 (1-\alpha_1 T_1 \Sigma E_i A_i / (P+\alpha_1 T_1 E_1 A_1)), \quad (15)$$



$$k_1 = (1 - \alpha_1 T_1 \Sigma E_i A_i) / (P + \alpha_1 T_1 E_1 A_1). \quad (16)$$

In the considered cases one-dimensional FE were used, but to make a generalization for two-dimensional elements using equivalent stresses is not a problem.

When solving the problem of plasticity, the stress-strain diagram of the material element (Fig.5) is used. For an iterative solution of a physically nonlinear problem, an approach similar to pseudoelastic modules is known as the "fictitious module" method. Unlike the "fictitious loads" method, which solves the system of equations in the form of (6), this method will require a recalculation of the stiffness matrix

$$K^* v = P, \quad (17)$$

where  $K^*$  is the corrected stiffness matrix taking into account recalculation of element stiffness when using pseudo-elastic modules at each iteration step. For the element (see Fig.6) we have  $\beta_j = \arg \operatorname{tg} e_j$ , where  $j$  is the iteration number.

In the creep problem, it is necessary to know the creep curves of the force elements (the dependence of the deformation of the material in time at a given load and temperature) – Fig.6. Calculation is carried out by steps on time. It is possible to use the isochronous curves, when the characteristics of creep in a fixed moment of time are presented in the form of non-linear dependencies of the voltage from the strain. This solution method allows to transform calculations on creep at each time step to the solution of problems of the deformation theory of plasticity algorithm, as it was showed already in Fig.5.

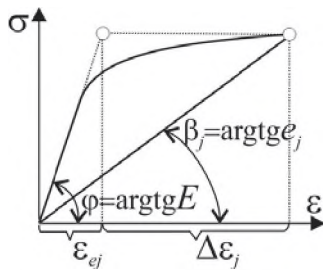

Fig.5. Stress-strain diagram with plasticity

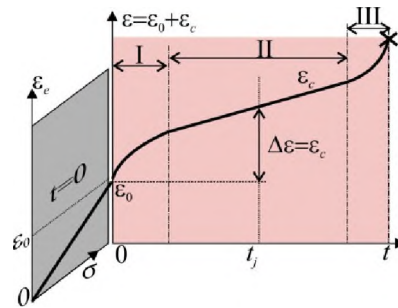

Fig.6. Creep curve with the three stages of one

The worth of based the proposed pseudo-elastic stiffness approach will manifest itself in design tasks. Most optimization algorithms are developed and justified for linear problems without taking into account initial deformations. In this regard, we can use optimization in the presence of heating or physical nonlinearity by formal replacement of the real modules of elasticity on pseudoelastic allows you to simply reduce the problem to quasi-elastic, preserving the existing optimization algorithm. In this case, the pseudo-elasticity module on the subsequent iteration is taken from the previous one.

Let us consider a widespread algorithm for designing structures of maximum rigidity. As a single value characterizing stiffness properties of the structure as a whole, the characteristic of General (integral) stiffness is usually used. The work of external forces  $A$  in the elastic system goes to potential energy of elastic deformations (PED) –  $U$ . So it is obvious that the reduction of  $U$  causes a decrease of  $A$ , and this will lead to a decrease in the displacement of the elastic body under constant external loads, and, therefore, an increase in the stiffness of the structure as a whole within the specified volume of the load-carrying structure. In accordance with this approach, in the design of structures without taking into account heating to ensure maximum integral stiffness as the target function was used PED, which was minimized within a given

volume. Thus, when redistributing the material in the process of optimization  $U$  plays the role of elastic compliance, which is opposite to the value of the integral stiffness of the structure.

This optimization approach, first formulated in [2], boils down to the criterion

$$U = \frac{1}{2} \int_V \boldsymbol{\varepsilon}^T \boldsymbol{\sigma} dV = \frac{1}{2} \int_V u dV = \min \quad (18)$$

where  $u$  is the specific PED.

This approach was most widely used in the Samara scientific school, starting with the work [3], then [4] for two-dimensional elements and in many subsequent works, including structural design [5]. For the first time the use of this approach for heated structures was considered in [6].

Obviously, in the case of materials use with different densities, instead of the volume the mass of the structure should be considered. Taking into account the type of FE accepted in this work and the constancy of deformations within their limits, the expression for PED will be as follows

$$U = \frac{1}{2} \sum_{i=1}^n \frac{N_i^2 S_i}{E_i h_i}, \quad (19)$$

where  $N_i$  is the stress for one-dimensional and  $N_i = \sigma_{xi} h_i$  is the flow of effort for two-dimensional elements

$$N_i^2 = [R_{xi}(R_{xi} - \mu R_{yi}) + R_{yi}(R_{yi} - \mu R_{xi}) + 2(1 + \mu)R_{xyi}^2] S_i / (2 E_i h_i);$$

$$R_{xi} = \sigma_{xi} h_i; R_{yi} = \sigma_{yi} h_i; R_{xyi} = \tau_{xyi} h_i.$$

Thus, the problem reduces to minimization of the target function  $F(\mathbf{S}, \mathbf{h})$  in the space of assigned structural  $\mathbf{S} = \{S_1, S_2, \dots, S_n\}$  and sought design parameters  $\mathbf{h} = \{h_1, h_2, \dots, h_n\}$  with limitations  $\varphi_i \leq 0$ ,  $i=1, \dots, q$ . As the target function acts PED of all FE

$$F = U(\mathbf{S}, \mathbf{h}) - \min. \quad (20)$$

As  $\varphi$  it is convenient to use only one restriction, in this case, the preservation of the total mass  $M$

$$\varphi = M - M_0 = 0, \quad (21)$$

where  $M_0$  is the specified mass of the load-carrying structure. Other restrictions (on stresses, on the minimum values of design parameters) can be taken into account at the software level. In the case of using all the elements of the material of the same density as the limit will be the volume.

Further, if we are talking about the design of the structure with initial deformations, the formal replacement in (19)  $E_i$  on  $e_i$  is performed. At the same time, it should be remembered that when optimizing a design with initial deformations for some elements  $e_i$  may be negative (see Table 2). And this is manifested only when very significant heating, when the total deformation in the element will be the opposite direction from the elastic. Obviously, to reduce  $F$ , you need to set the design parameters of these elements to the minimum  $h_i = \underline{h}_i$  ( $i=m+1, m+2, \dots, n$ ), excluding them from the list of parameters with active constraints. Then the target function will be written in the following form

$$F = \frac{1}{2} \sum_{i=1}^m \frac{N_i^2 S_i}{e_i h_i} + \frac{1}{2} \sum_{i=m+1}^n \frac{N_i^2 S_i}{\underline{e}_i \underline{h}_i}. \quad (22)$$

The problem of minimizing (22) with the constraint (21) is solved by the method of indefinite Lagrange multipliers under the assumption of independence of  $N_i$  (force in a one-

dimensional linear elements and efforts in the two-dimensional), as well as the modules  $e_i$  of the design parameters  $h_i$ . For this purpose Lagrangian is formed

$$L = \frac{1}{2} \sum_{i=1}^m \frac{N_i^2 S_i}{e_i h_i} + \frac{1}{2} \sum_{i=m+1}^n \frac{N_i^2 S_i}{e_i h_i} + \lambda (M^+ + M^- - M_0), \quad (23)$$

where  $\lambda$  is the Lagrange multiplier, which is a constant value;  $M^+$ ,  $M^-$  are the masses of the structure, respectively, with active and passive design parameters

$$M^+ = \sum_{i=1}^m \rho_i S_i h_i, \quad M^- = \sum_{i=m+1}^n \rho_i S_i \bar{h}_i. \quad (24)$$

The conditions of minimum determine the  $m+1$  equations

$$\frac{dL}{dh_i} = -\frac{N_i^2 S_i}{2e_i h_i^2} + \lambda \rho_i = 0, \quad i=1, 2, \dots, m; \quad (25)$$

$$\frac{dL}{d\lambda} = M^+ + M^- - M_0 = 0. \quad (26)$$

From equations (25) follows

$$h_i = \frac{|N_i|}{\sqrt{2\lambda \rho_i e_i}}. \quad (27)$$

The substitution (27) in (26) with (24) determines  $\lambda$  and the final form of the recurrent formula for calculating the design parameters of the FE

$$h_i = \frac{|N_i|}{\sqrt{e_i \rho_i}} \frac{M_0 - M^-}{\sum_{i=1}^m \left( \frac{N_i^2 S_i^2 \rho_i}{e_i} \right)^{1/2}}, \quad i=1, 2, \dots, m. \quad (28)$$

The analysis of expression (27) allows to draw an important conclusion concerning distribution of material in elements

$$\lambda = N_i^2 / (2h_i^2 \rho_i e_i) = \varepsilon_i \sigma_i / (2\rho_i) = \text{const}, \quad i=1, 2, \dots, m. \quad (29)$$

It is obvious that in order to obtain the maximum rigidity structure taking into account the initial deformations in elements with positive  $e_i$ , it is necessary to ensure the constancy of the specific potential energy of complete deformations adjusted with the density of the material. In the absence of initial deformations and with elements of the same density condition (29) corresponds to the well-known theorem Z. Wasiutynski [1]: a system with a given volume of material takes a form corresponding to the minimum deformation energy, if the value of the specific deformation energy is the same at all points of the system.

As an example, testing the proposed algorithm, we consider a three-rod truss (Fig.7) with the following parameters:  $E=70$  GPa,  $\sigma_{Ult}=200$  MPa,  $P=20$  kN,  $l=1$  m. The truss is being acted the vertical force and symmetric heating in a wide range of temperature change of the second central element. In the beginning, we consider a construction with elements of the same area found from the condition of reaching additional  $\sigma_{Ult}$  in one of the elements only from the external load without heating. In the process of numerical investigation, a search of the structure design for maximum rigidity of the fixed external load at various temperatures of the second element within a given volume of the material of the rods. To simplify the task, the influence of temperature on mechanical characteristics was not taken into account. On the above chart shows the change in the work of external forces, the displacement of the point of loading, at initial and optimal designs, the voltages in the rods. In this case, the dashed lines correspond to the

parameters of the original project ( $h_1 = h_2 = h_3 = 0.585 \text{ cm}^2$ ), solid lines correspond to the parameters obtained with  $A_{\min}$  (the most rigid construction). The minimum allowed value of the rod area was  $0.01 \text{ cm}^2$ .

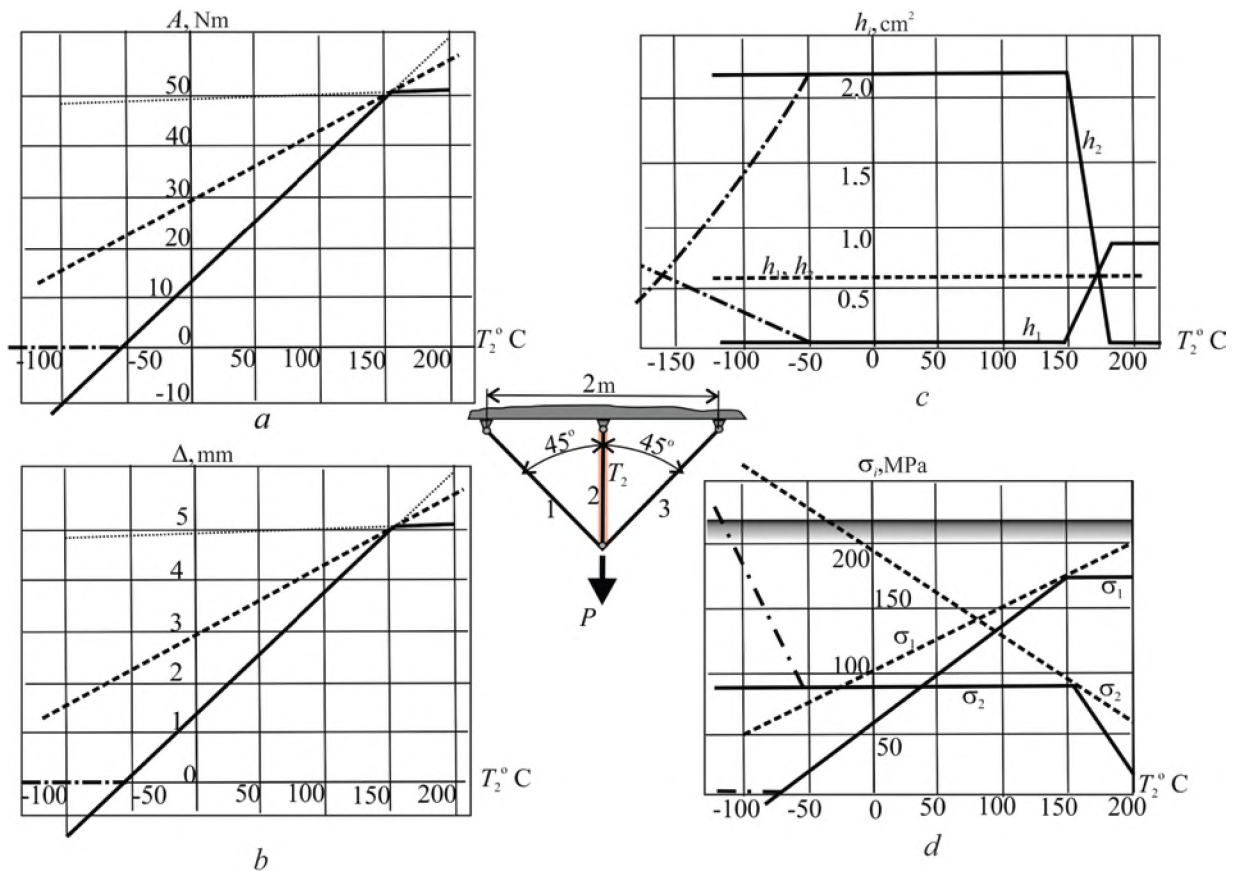

Fig.7. Three-rod truss with heated central rod:  $a$  – work of external forces;  $b$  – displacement of the nodal point;  $c$  – the areas of rods sections;  $d$  – stresses in the elements. Designations:

----- the initial design at  $h_i = 0.585$ ; ———— parameters at  $A_{\min}$ ; - · - · -  $|A_{\min}|$

In the range of permissible stresses, the following temperature zones can be distinguished, to which their optimal projects will correspond:

Zone 1:  $T < -50^\circ\text{C}$ . this zone is characterized by the fact that in the process of optimization the positive value of  $a$  is changed to negative.

Zone 2:  $-50^\circ\text{C} < T < +150^\circ\text{C}$ . In this wide temperature range, only one design corresponding to the non-heated design is optimal.

Zone 3:  $+150^\circ\text{C} < T < +200^\circ\text{C}$  – the transition zone is not heated from optimal design to optimal heated.

Zone 4.  $T > +200^\circ\text{C}$ . The optimum is a project with a heated element of the minimum area.

Temperatures at which the elements are no negative modulus pseudoelasticity will be called moderate. As can be seen from the graphs, for the considered example, only two optimal projects are of practical value:

for moderate temperatures – the project corresponding to the construction of not heated;

for temperatures above moderate – the project heated design.

### 3. CONCLUSIONS

Thus, the application of the proposed method makes it simple enough to reduce the problem of designing structures that need to take into account initial deformations and different materials in load-carrying elements to the existing known algorithms and optimization methods.

### REFERENCES

- [1] Wang Z., Kang L., Huan S., Kretov A. S. Strength Design Model of Thin-walled Structures. *Izv. VUZov. Aviatsionnaya Tekh. (Proc. of High Educ. Inst. Aviation Technol.)*, No.4, pp. 116-122, 2015. (In Russian)
- [2] Wasitynski Z. On the Congruency of the Forming According to the Minimum Potential Energy with that According to the Equal Strength. *Bulletin de L'Academic Polonaise des Sciences, Serie des Sciences Techniques*, vol. VIII, No.6, 1960.
- [3] Komarov A. A. Basics of Designing Power Structures, Kuibyshev Book Publ. , Kuibyshev, 1965. 82p. (In Russian)
- [4] Komarov V. A. On rational Power Constructions of Small Wings Elongations. // *Tr. Kuibyshev Aviation. Ins*, vol. 32, pp. 6-26, 1968. (In Russian)
- [5] Boldyrev A. V. and Komarov V. A. Structural Optimization of the Lifting Surfaces with Account of Static Aeroelasticity. *Izv. VUZov. Aviatsionnaya Tekh. (Proc. of High Educ. Inst. Aviation Technol.)*, No. 2, pp. 3–6, 2008. (In Russian)
- [6] Kretov A. S. On the Design of Heated Power Structures. *Izv. VUZov. Aviatsionnaya Tekh. (Proc. of High Educ. Inst. Aviation Technol.)*. No. 3, pp. 9-15, 1998. (In Russian)

#### Speaker



Samuel E. Nana Agyeman

## ABOUT CURRICULUMS FOR THE FOREIGN GRADUATE STUDENTS MAJORING IN "AIRCRAFT DESIGN" OF NUAA

ZhiJin Wang, Anatolii Kretov

Nanjing University of Aeronautics and Astronautics, College of Aerospace Engineering,  
29 Yudao St., Nanjing 210016, P.R.China

e-mail: [zhijin@nuaa.edu.cn](mailto:zhijin@nuaa.edu.cn); [kretov-ac@nuaa.edu.cn](mailto:kretov-ac@nuaa.edu.cn)

**Key words:** Curriculums, Aircraft Design, Foreign graduate students, Nanjing University of Aeronautics and Astronautics

**Abstract.** *The work is devoted to the consideration and analysis of curricula for foreign students enrolled in the master's degree program of the NUAA in the direction associated with the aircraft design.*

### 1. INTRODUCTION

With the development of the aviation industry, the number of aircraft for various purposes is constantly growing. A number of major players in the aviation market tried to make a forecast about the prospects for the development of world civil aviation. A similar task has been addressed in the USA by Boeing and by China aviation Corporation COMAC. And the results of the forecasts of both companies are quite similar. As for the fleet of aircraft, there are about 18.2 thousand copies in the world today. Passenger aircraft of different classes carry out about 25 thousand flights daily – Fig.1.



Fig.1. Aircraft movement map

And in twenty years, this number should be doubled, and will reach to 37.2 thousand aircraft. As for the financial side, the global volume of procurement will be about 4 trillion dollars. The largest surge will be in South East Asia. There, the growth of annual passenger traffic exceeds the global one twice (4.9% against 7.2%). (<http://www.poletim.net/>)

It is obvious that, with the quantitative growth of the aircraft fleet, qualitative changes will be required, and consequently the number of specialists associated with the design and

construction of this equipment should be grown. Currently, China is the most dynamically developing country in all areas, including in the field of aircraft construction and education.

In this regard, more and more foreign students will come to study at Chinese universities. One of the most difficult and time-consuming training is inmajor associated with the Aircraft Design (AD).

## 2. MAIN PART

Let us focus on the training problem of foreign graduates students in major “aviation design”.

The most important problem is determining the correct training direction for student in accordance with his chosen training direction and the formation of a balanced curriculum. As you know, the curriculum is a structured document that includes: training schedule, list of subjects, the number of hours and their respective credit units.

Among the students who come to study in Nanjing University of Astronautics and Aeronautics (NUAA), there is a certain number of people who are eager to design and build aircraft.

If these students start their studies with a baccalaureate in the NUAA, then it is easier for such students to enter the graduate students’ program. For these students is offered a wide range of disciplines. Unfortunately, the student in them is still poorly oriented. In each semester, you need to dial a certain number of credits, so that at the end he had about 180 units.

In table.1 shows an example of an extract from the diploma of one of the foreign students who studied at the College of International Education of NUAA inthe Major of Aeronautical Engineering.

Table 1

No	Courses	Hours	Credits	GP	Score	Remark
1	Engineering Graphics	56	3.5	1.6	66	C
2	Linear Algebra	48	3.0	4.1	91.0	C
3	Algebra &Trigonometry	48	3.0	4.0	90.0	C
4	Introduction to Computer	32	2.0	4.1	91.0	C
5	Orientation Program	24	1.5	3.0	80.0	C
6	Basic Chinese Speaking	32	2.0	4.9	99.0	C
7	Comprehensive Chinese(1)	48	3.0	5.0	100.0	C
8	Introduction to China	24	1.5	4.5	95.0	C
9	Physical Education(1)	24	0.5	3.5	85.0	C
	<b>First Term GPA</b>	336	20	3.9		
11	Introduction to Aeronautics	32	2.0	4.8	98.0	C
12	Calculus for Engineering Sciences(1)	48	3.0	4.5	95.0	C
13	Physics(1)	32	2.0	4.4	94.0	C
14	Physics Experiments(1)	16	0.5	3.5	G	C
15	Introduction to Business Administration	48	3.0	3.6	86.0	0
16	Computer Programming	72	4.0	1.0	60	C
17	Basic Chinese Listening	32	2.0	4.4	94	C
18	Comprehensive Chinese(2)	48	3.0	5.0	100	C
19	Chinese Culture	24	1.5	4.4	94	C
20	Essential English Writing	40	2.5	3.6	86	O
21	Physical Education(2)	34	0.5	4.2	92	C
	<b>Second Term GPA</b>	426	24	3.8		
22	Engineering Mechanics I (1)	58	3.5	3.6	87	C
23	Electrical Engineering & Electronic Technique (1)	52	3.0	2.9	79	C

24	Calculus for Engineering Sciences (3)	48	3.0	2.0	70	C
25	Calculus for Engineering Sciences (2)	32	2.0	2.6	76	C
26	Physics Experiments (2)	24	0.5	3.5	G	C
27	Physics (2)	56	3.5	4.4	94	C
28	Engineering Economics	40	2.5	2.0	70	O
29	Comprehensive Chinese(3)	48	3.0	4.9	99	C
30	Academic English Writing	48	3.0	3.6	86	C
31	Reading in Chinese	32	2.0	3.0	80	O
32	Physical Education(3)	26	0.5	2.7	77	C
33	Information Retrieval & Utilization	16	0.5	1.9	69	O
34	Engineering Training	2	2.0	3.2	82	C
	<b>Third Term GPA</b>	482	29	3.3		
35	Engineering Mechanics I (2)	58	3.5	4.1	91	C
36	Electrical Engineering & Electronic Technique (2)	52	3.0	3.5	85	C
37	Fundamentals of Materials Science and Engineering	48	3.0	4.3	93	C
38	Numerical Analysis	32	2.0	4.4	94	C
39	Mathematical Equations	24	1.5	1.3	63	C
40	Matlab Applications	24	1.5	2.7	77	O
41	Intermediate Chinese	32	2.0	2.3	73	O
42	Physical Education(4)	20	0.5	5.0	100	C
43	Course Project: Electrical & Electronic Technique	1.5	1.5	2.5	M	C
	<b>Fourth Term GPA</b>	291.5	18.5	3.5		
44	Aerodynamics	58	3.5	1.6	66.0	C
45	Introduction to Aero engine	48	3.0	2.2	72.0	C
46	Control System Engineering	51	3.0	3	80.0	C
47	Fundamentals of Machine Design	58	3.5	2.3	73.0	C
48	Course Project:Fundamentals of Machine Design	2	2.0	3.5	G	C
49	Introduction to Aircraft Manufacturing Technology	32	2.0	2.5	75.0	C
50	Introduction to Industrial Engineering	40	2.5	3.8	88.0	O
51	Project Management	32	2.0	2.9	79.0	O
52	Chinese-to-English Translation	32	2.0	3.8	88.0	O
53	Software Engineering	48	3.0	3.3	83.0	O
54	Physical Education(5)	20	0.5	3.5	G	C
	<b>Fifth Term GPA</b>	421	27	2.9		
55	Flight Dynamics	48	3.0	1.5	65.0	C
56	Fundamentals of CATIA 3D Design	24	1.5	3.5	G	C
57	Introduction to CAD/CAM	54	3.0	3.1	81.0	C
58	Fault Diagnosis & Monitoring	56	3.5	3.7	87.0	O
59	Aeronautical Maintenance Engineering	40	2.5	1	60.0	C
60	Course Project: Modern Aeronautical Engineering	20	1.0	3.5	G	C
61	Engine Maintenance & Product Practice	60	3	4.5	E	C
62	Introduction to E-Business	32	2	3.2	82	O
63	Human Resources Management	32	2	3.6	86	O
64	Basic Writing in Chinese	32	2	4.4	94	O
65	Physical Education(6)	20	0.5	3.5	G	C
	<b>Sixth Term GPA</b>	418	24	3.2		
66	Aircraft Preliminary Design	40	2.5	3	80	C
67	Aircraft Structural Design	56	3.5	4.2	92	C
68	Structural Analysis	64	4	1.5	65	C
69	Mechanical Vibration	48	3	2.9	79	O
70	Project of Smart Materials and Structures Applied in Aerospace Engineering	32	2	3.5	85	O
71	Aircraft Environment Control	48	3	1.6	66	C
72	Structure and Maintenance of Composite Materials	48	3	2.9	79	O



73	Physical Education(7)	20	.5	3.5	G	C
	<b>Seventh Term GPA</b>	356	21.5	2.8		
74	<b>Graduation Project</b>	17	17	3.1	81	C
	<b>Eighth Term GPA</b>			3.1		
	<b>Total amount</b>					
	Courses	Hours	Credits	GP	Score	Remark

Note: disciplines directly related to AD are shown in a pistachio background

Let's make a selection of disciplines related directly to the AD – Table.2.

Table 2

No	Courses related directly with AD	Hours	Credits	GP	Score	Remark
1	Introduction to Aeronautics	32	2.0	4.8	98.0	C
2	Fundamentals of Materials Science and Engineering	48	3.0	4.3	93	C
3	Flight Dynamics	48	3.0	1.5	65.0	C
4	Fundamentals of CATIA 3D Design	24	1.5	3.5	G	C
5	Introduction to CAD/CAM	54	3.0	3.1	81.0	C
6	Fault Diagnosis & Monitoring	56	3.5	3.7	87.0	O
7	Aeronautical Maintenance Engineering	40	2.5	1	60.0	C
8	Course Project: Modern Aeronautical Engineering	20	1.0	3.5	G	C
9	Engine Maintenance & Product Practice	60	3	4.5	E	C
10	Aircraft Preliminary Design	40	2.5	3	80	C
11	Aircraft Structural Design	56	3.5	4.2	92	C
12	Structural Analysis	64	4	1.5	65	C
13	Mechanical Vibration	48	3	2.9	79	O
14	Project of Smart Materials and Structures Applied in Aerospace Engineering	32	2	3.5	85	O
15	Aircraft Environment Control	48	3	1.6	66	C
16	Structure and Maintenance of Composite Materials	48	3	2.9	79	O
17	Graduation Project	17	17	3.1	81	
	<b>Total amount</b>	735	60.5			

In the all of the 74 disciplines with a total volume of 2747.5 hours, only 17 disciplines are directly related to the AD, their volume is 735 hours. Let's compare by semesters the ratio of hours and credits of the total number of disciplines with disciplines directly related to AD – Tabl.3.

Table 3.

Term	All disciplines		Disciplines directly related to AD		Hours Hours <sup>AD</sup>
	Hours	Credits	Hours <sup>AD</sup>	Credits	%
1	336	20	0	0	0.0
2	426	24	32	2.0	7.5
3	482	29	0	0	0.0
4	291.5	18.5	48	3.0	16.5
5	421	27	369	24.5	87.6
6	418	24	302	17.5	72.2
7	356	21.5	336	21	94.4
8	17	17	17	17	100.0
Σ	2747.5	181	1104	85	40.2

As we can see, the curriculum for bachelors of the NUAA for foreign students gives them good opportunities to continue their education in the master's degree in the direction of AD.

At the same time, for bachelors who come from other countries and choose the direction of AD may be a problem with basic training. Let's analyze the extracting from the diploma of a bachelor student who came from Central Asia, where he studied in the direction of "Computer science and information technologies (on branches)". It Bachelor's learning involves the total volume of 7430+400 (additional items)+200 (practical) + 200 (state certification)=8230 hours. At the same time, the number of items that can be somehow connected with aviation is absolutely scanty – 6.2% (Tabl.4).

Table 4

No	Disciplines directly related to AD	Hours	Note
1	Computer graphics and design	120	
2	Mathematical modeling	138	
3	Metrology, standardization and certification	154	
4	Information system design	106	
	<b>Total amount</b>	518	

It is obvious that it is impossible to train such a student in the graduate students even with all the great desire of this student. Although in any rule can be exceptions.

In the first year undergraduates are guided by the disciplines provided by the curriculum. These subjects may be compulsory or optional.

The College of aerospace engineering offers undergraduate students 36 compulsory disciplines. For foreign undergraduates in English, there are only 4 compulsory subjects.

For all graduate students there are 399 subjects for choice. At the same time for foreign graduate students only 25 disciplines are read in English: in the fall Semester – Tabl.5; in the spring Semester – Tabl.6.

Table 5

No	NoofDiscipline	Fall's Courses (秋)	Hours	Credits	Note
1	6A010001L (Obligatory)	Overview of Aeronautics and Astronautics	30	2	Fall Semester
2	6A080001L (Obligatory)	Matrix Theory	60	4	Fall
3	6A120006L (Obligatory)	Chinese	60	4	Fall
4	6B012001L	Aircraft Design	48	3	Fall
5	6B013005L	Finite Element Structural Analysis	40	2.5	Fall
6	6B015003L	Environment Control System for Aircraft and Refrigerant Technology	48	3	Fall
7	6B041001L	Advanced Electromagnetic Theory	48	3	Fall
8	6B041003L	Numerical Methods for Electromagnetic Fields	48	3	Fall
8	6B042006L	Digital Communications	48	3	Fall
10	6B052003L	Non-traditional Machining	48	3	Fall
11	6B054002L	Principles of Metal Forming	48	3	Fall
12	6B061005L	Polymer Science	48	3	Fall
13	6B073007L	Aircraft Electricity System	32	2	Fall
14	6B081001L	Functional Analysis	48	3	Fall
15	6B081010L	Numerical Analysis	40	2.5	Fall
16	6B082001L	Advanced Quantum Mechanics	48	3	Fall

17	6B091002L	Advanced Operations Research	56	3.5	Fall
18	6B091006L	Advanced Statistics	32	2	Fall
19	6B092002L	Advanced Management	32	2	Fall
20	6B093009L	International Finance Management	32	2	Fall
21	6B153002L	Satellite and Mobile Communication Engineering	32	2	Fall
22	6B154003L	Dynamics in the Middle and Upper Atmosphere	32	2	Fall
		<b>Total amount</b>	958	60.5	Fall

Note: disciplines directly related to AD are shown on a pistachio background; obligatory disciplines are shown on a red one

Table 6

No	No of Discipline	Spring's Courses (春)	Hours	Credits	Note
1	6A120007L (Obligatory)	Chinese Culture	45	3	Spring Semester
2	6B031004L	Theory and Application of Nonlinear Control System	32	2	Spring
3	6B031008L	Digital Control System: Theory and Design	32	2	Spring
4	6B031011L	Globe Navigation Satellite System	32	2	Spring
5	6B031015L	Fuzzy Modeling and Control	32	2	Spring
6	6B031017L	Fault Estimation and Accommodation for Dynamic Systems	32	2	Spring
7	6B041002L	Antenna Theory and Technique	48	3	Spring
8	6B042003L	Channel Coding: from Theory to Practice	32	2	Spring
9	6B052004L	Metal Cutting Principle	48	3	Spring
10	6B054001L	Computer-Aided Design and Its Applications	48	3	Spring
11	6B072003L	Air Transportation System Analysis and Modeling	48	3	Spring
12	6B082004L	Theory of Solid State Physics	48	3	Spring
13	6B091018L	Decision Analysis and Making	48	3	Spring
14	6B092006L	Technical and Economic Analysis	32	2	Spring
15	6B093007L	International Trade	32	2	Spring
16	6B093008L	Macroeconomics	32	2	Spring
17	6B093010L	Energy and Environmental Economics	32	2	Spring
18	6B151002L	Space Robotics	40	2.5	Spring
19	6B162002L	Advanced Software Engineering	48	3	Spring
20	6B162003L	Software Metrics	40	2.5	Spring
21	6B169002L	Logic for Applications	48	3	Spring
22	6B169003L	Combinatorial Mathematics	48	3	Spring
		<b>Total amount</b>	877	55	Spring

Note: disciplines directly related to AD are shown on a pistachio background; obligatory disciplines are shown on a red one.

Let's select on the semesters, only those disciplines that are directly related to AD, as well as the required disciplines: Fall Semester – Tabl.7; Spring Semester – Tabl.8.

By this the student-master must earn approximately 14 credits each semester.

The second year for masters is devoted entirely to individual work with the supervisor on the topic of graduation work. If necessary a student can listen to additional subjects, related to the specifics of his thesis.

Table 7

No	No of Discipline	Fall's Courses (秋) related directly with AD and obligatory courses	Hours	Credits	Note
----	------------------	--	-------	---------	------

1	6A010001L (Obligatory)	Overview of Aeronautics and Astronautics	60	1	Fall Semester
	6A080001L (Obligatory)	Matrix Theory	40	1	Fall
	6A120006L (Obligatory)	Chinese	40	1	Fall
4	6B012001L	Aircraft Design	48	3	Fall
5	6B013005L	Finite Element Structural Analysis	40	2.5	Fall
6	6B015003L	Environment Control System for Aircraft and Refrigerant Technology	48	3	Fall
7	6B073007L	Aircraft Electricity System	32	2	Fall
8	6B153002L	Satellite and Mobile Communication Engineering	32	2	Fall
9	6B154003L	Dynamics in the Middle and Upper Atmosphere	32	2	Fall
		<b>Total amount</b>	382	24.5	Fall
		<b>Minimum credits level</b>		14	Fall

Table 8

No	No of Discipline	Spring's Courses (春) related directly with AD and obligatory courses	Hours	Credits	Note
	6A120007L (Obligatory)	Chinese Culture	16	1	Spring Semester
2	6B054001L	Computer-Aided Design and Its Applications	48	3	Spring
3	6B072003L	Air Transportation System Analysis and Modeling	48	3	Spring
4	6B151002L	Space Robotics	40	2.5	Spring
5	6B162002L	Advanced Software Engineering	48	3	Spring
		<b>Total amount</b>	229	14.5	Spring
		<b>Minimum credits level</b>		14	Spring

Note: disciplines directly related to AD are shown on a pistachio background; obligatory disciplines are shown on a red one.

### 3. CONCLUSIONS

1. With the growing interest of the foreign students in Chinese education, including in the direction of AD, it is necessary to further improve the curriculums.
2. When receiving foreign students who have get a bachelor's degree at home, it is necessary to comprehensively analyze content of their bachelor's education for reasonably choosing of future education direction.
3. It is necessary to expand the list of disciplines in English teaching for foreign students, and especially related to the direction of AD.

#### Authors



ZhiJin Wang



Anatolii Kretov

# STRUCTURE AND PROPERTIES OF DRAGONFLY WINGS: COMPOSITE STRUCTURE OF FIBROUS MATERIAL SUPPLEMENTED BY RESILIN

**Esther Appel, Hamed Rajabi and Stanislav Gorb**

Department of Functional Morphology and Biomechanics, Zoological Institute  
of the University of Kiel, Am Botanischen Garten 9, D-24118 Kiel, Germany  
e-mail: sgorb@zoologie.uni-kiel.de

**Key words:** Dragonfly, wing, structure, load carrying elements, materials, joints.

**Abstract.** *The structure of the dragonfly wing, which is a unique example of optimal design, is considered. Modern methods of analysis are used and the explanation of some design features of a wing of a unique insect is given.*

## 1. INTRODUCTION

The exceptional aerodynamic performance and damage tolerance of dragonfly wings is due to the combination of their fascinating macro- and microscopic structural design and material composition. Morphological and kinematic investigations have shown that dragonfly wings, though being rather stiff, are able to undergo passive deformation during flight, thereby improving the aerodynamic performance. Resilin, a rubber-like protein, has been already found in wing vein joints, connecting longitudinal veins to cross veins, and was shown to endow dragonfly wings with chordwise flexibility, thereby most likely influencing dragonfly flight performance (Fig.1) (Gorb, 1999). However, resilin was recently revealed in the internal cuticle layers of veins (Figure 2 a) (Appel et al., 2015). Combined with other structural features of veins, such as number and thickness of cuticle layers, material composition, and cross-sectional shape, resilin most probably has an effect on the effective material properties of veins and by this also on the degree of elastic deformations.

## 2. MAIN PART

This paper combines the approaches of bright-field light microscopy, wide-field fluorescence microscopy, confocal laser-scanning microscopy, scanning electron microscopy and transmission electron microscopy and shows that veins consist of up to six different cuticle layers. Longitudinal and cross veins differ significantly in relative thickness of exo- and endocuticle, with cross veins showing a much thicker exocuticle. The presence of resilin in the unsclerotised endocuticle suggests its contribution to the increased energy storage and structural flexibility, thus to the prevention of vein damage. This is especially important in the highly stressed longitudinal veins, which should not fail subjected to the applied forces during flight, as in cross veins.

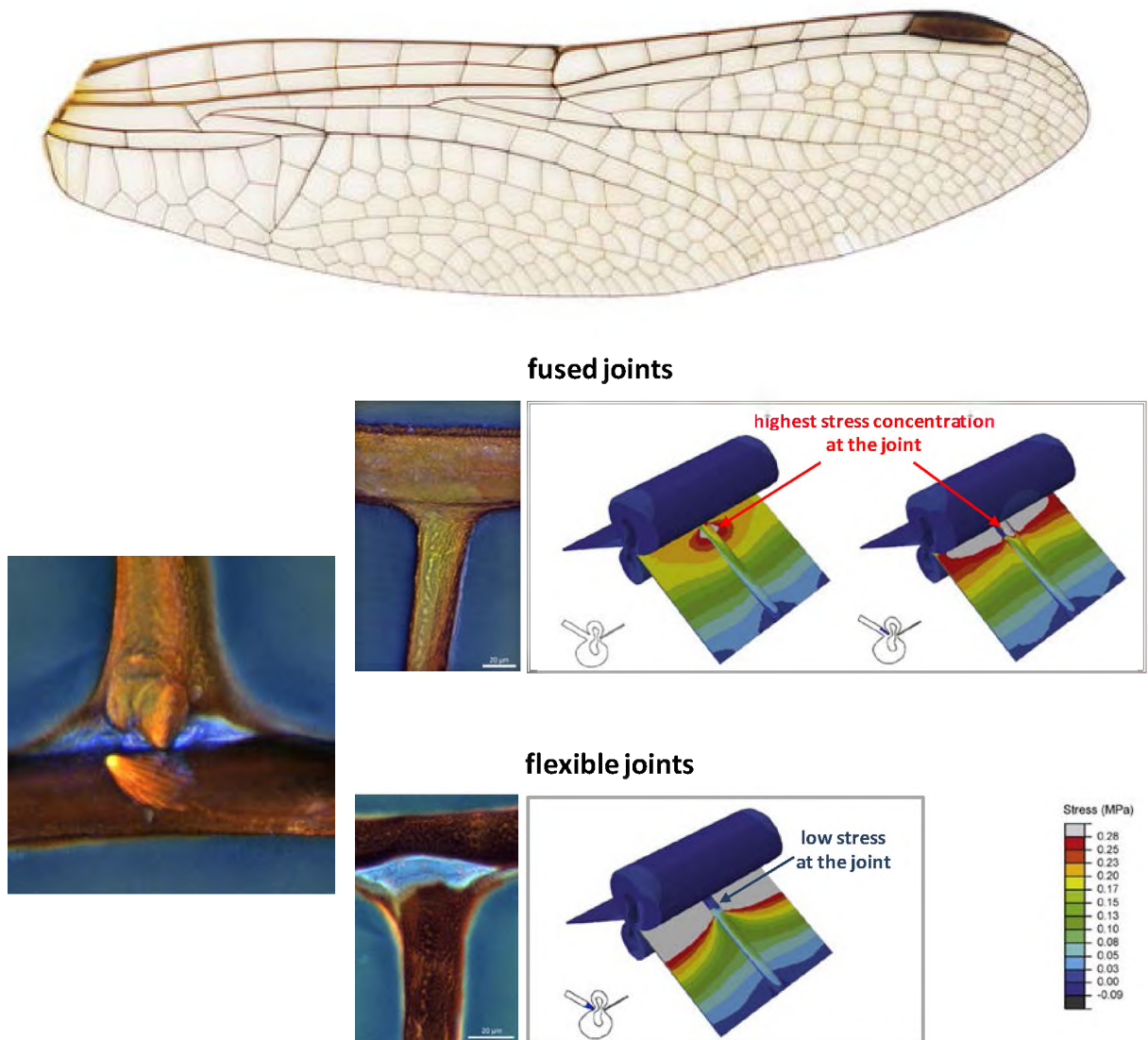

Fig.1. The anisopteran dragonfly forewing (upper panel) and two types of joints at the intersections of longitudinal veins and cross veins (for details see Rajabi et al., 2015)

Morphological data have been used to develop a series of three-dimensional numerical models with different material properties and geometries. Finite element analysis has been employed to simulate the mechanical response of the models under different loading conditions (Fig.2, b-d). Numerical simulations suggest that although the presence of the resilin-dominated endocuticle layer results in a much higher flexibility of wing veins, the dumbbell-shaped cross section increases their bending rigidity.

The rubber-like cuticle, friction between layers and material gradient-based design are expected to contribute to the higher damping capacity of veins.

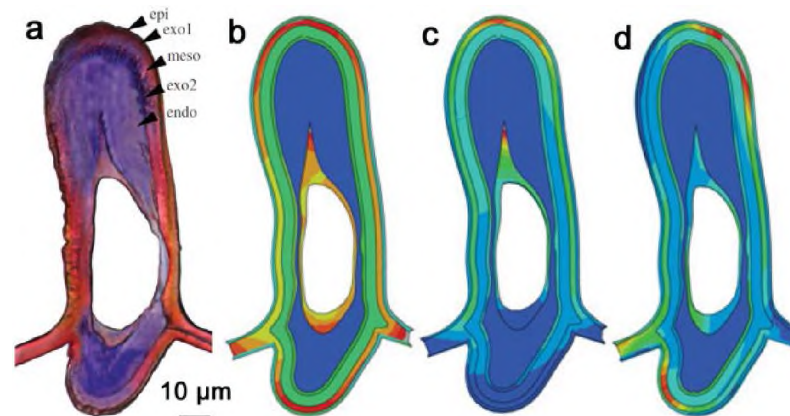

Fig.2. (a) Bright-field light microscopy image of the cross sections of the wing vein of the dragonfly *Sympetrum vulgatum* (Anisoptera, Libellulidae) (Appel et al., 2015). b-c. Distribution of the maximum principal stress at the fixed end of the vein models under (b) tension, (c) bending and (c) torsion (Rajabi et al., 2016)

### 3. CONCLUSIONS

Modern achievements of science open up great opportunities for the study of the creations of nature in order to understand them and further use in human activities. Such a striking example is the dragonfly wing, which the designer named Nature has created so unique that it can serve as a model in the design of new aircraft.

### REFERENCES

- [1] Appel, E., Heepe, L., Lin, C.-P., and Gorb, S. N. (2015) Ultrastructure of dragonfly wing veins: composite structure of fibrous material supplemented by resilin. *Journal of Anatomy*, 227(4): 561-582.
- [2] Gorb, S.N. (1999) Serial elastic elements in the damselfly wing: mobile vein joints contain resilin. *Naturwissenschaften*. 86: 552-555.
- [3] Rajabi, H. Rajabi, H., Ghoroubi, N., Darvizeh, A., Dirks, J.-H., Appel, E., and Gorb, S. N. (2015) A comparative study of the effects of vein-joints on the mechanical behaviour of insect wings:I. Single joints. *Bioinspiration & Biomimetics*, 10(5) No. 056003: 1-11.
- [4] Rajabi, H., Shafiei, A., Darvizeh, A., Dirks, J.-H., Appel, E., and Gorb, S. N. (2016) Effects of microstructure on the mechanical and damping behaviour of dragonfly wing veins. *Royal Society Open Science*, 3(160006): 1-12.

#### Speaker



Stanislav Gorb

## DESIGN AND MANUFACTURING OF AIRCRAFT HATCH FROM COMPOSITE MATERIALS USING THE TECHNOLOGY OF TAILORED FIBER PLACEMENT

**Daria Bezzametnova, Alexandra Kuzmina, Fariddun Boboev**

Kazan National Technical Research University named after AN. Tupolev-KAI

Tolstoy street, 15

420012, Kazan, Russia

e-mail: [alekkuzmina@mail.ru](mailto:alekkuzmina@mail.ru)

**Key words:** Composite materials, Tailored Fiber Placement, Bionic design, Integral structures.

**Abstract.** *The technology of manufacturing a hatch with bionic design made of polymer composite materials using the method of Tailored fiber placement is presented.*

The purpose of the work is to study the possibility of manufacturing a hatch preform by the method of Tailored fiber placement.

To manufacture the hatch with bionic design of polymer composite materials, a non-autoclave manufacturing technology for composite parts was proposed. The proposed manufacturing technology of the hatch from polymer composite materials consists of 2 stages. The first stage is the manufacture of a dry composite fiber manhole preform. The second stage is the “direct” process of molding of the composite part, which combines the process of impregnation of the part with a binder and pressure molding[1]. Tailored fiber placement technology was chosen for the manufacture of dry hatch preforms. The essence of the Tailored fiber placement technology is the automated layout of the composite fiber on the base material with the fastening of the upper and lower threads [2]. To implement the Tailored fiber placement technology, the specialized Tajima machine is used (Fig. 1), based on the principle of sewing on an embroidery machine. For Tailored fiber placement technology, the traditional embroidery machine was supplemented with a guide device for laying out composite roving.



Fig. 1. Specialized Tajima machine for Tailored fiber placement technology



The Unigraphics NX software has developed and designed an electronic 3D model of the hatch with bionic design (Fig. 2a). The construction of the hatch consists of the airframe and the power reinforcements of the hatch construction with the brackets (Fig. 2b). The size of the unit is 525\*525 mm.

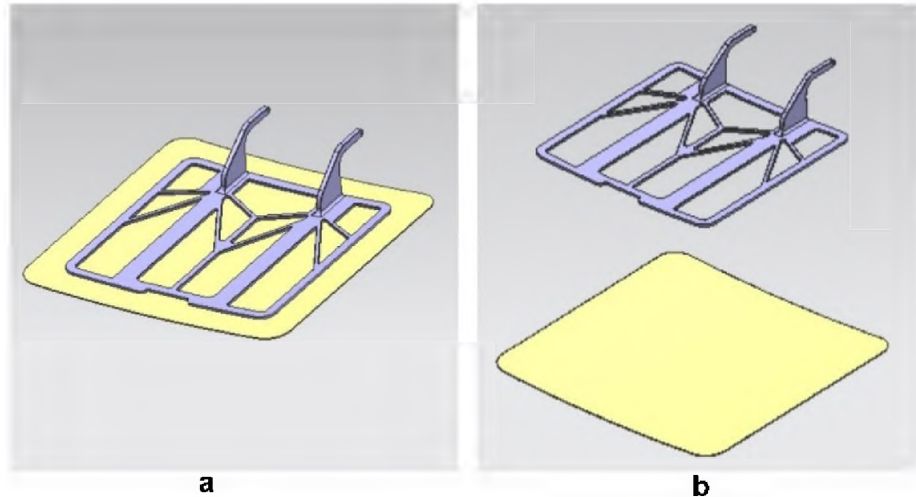

Fig. 2 - Electronic model of the hatch with bionic design:  
a – components of the hatch in the assembly; b – hatch components

Power reinforcement of the hatch is based on the application of bionic design in the design details. The design of the power reinforcement of the hatch (Figure 3a) was developed based on the structure of the butterfly wing (Fig. 3b).

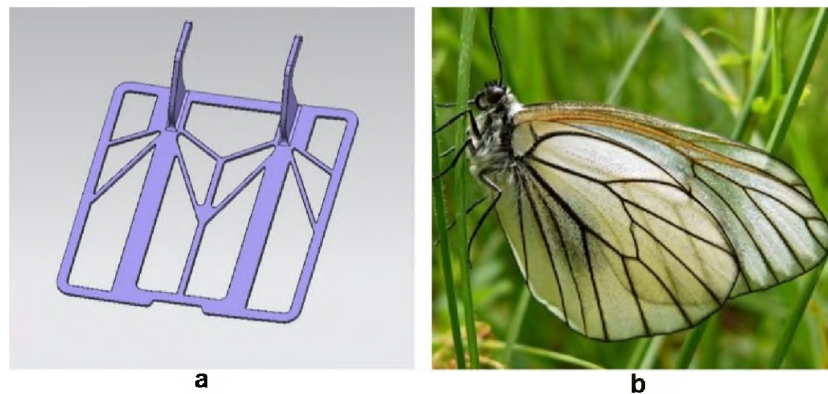

Fig. 3. Design of power reinforcement hatch:  
a – hatch reinforcement design; b – butterfly wing structure

Integral parts made of polymer composite have such significant advantages as the lack of assembly operations, the possibility of forming the part in one technological operation, and reducing the weight of the structure [3]. To create a unified integral structure of the power reinforcement of the hatch with brackets, the parts of the power reinforcement and brackets were divided into 3 sub-preforms (Fig. 4).

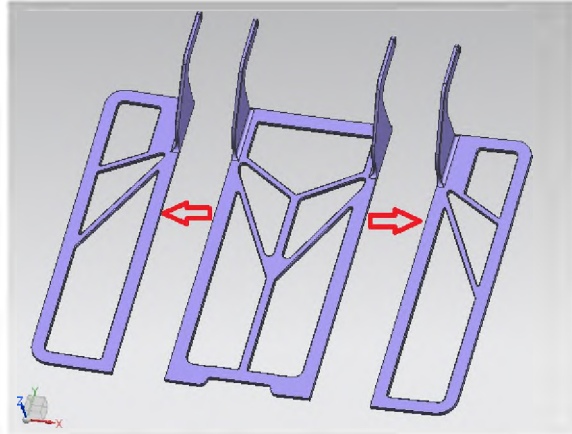

Fig. 4 - Dividing the structure into sub-preforms

The division of the part into sub-preforms takes place in the plane of symmetry of the brackets, so that the specialized Tajima machine for directional fiber placement can sew flat sub-preforms (Fig. 5).

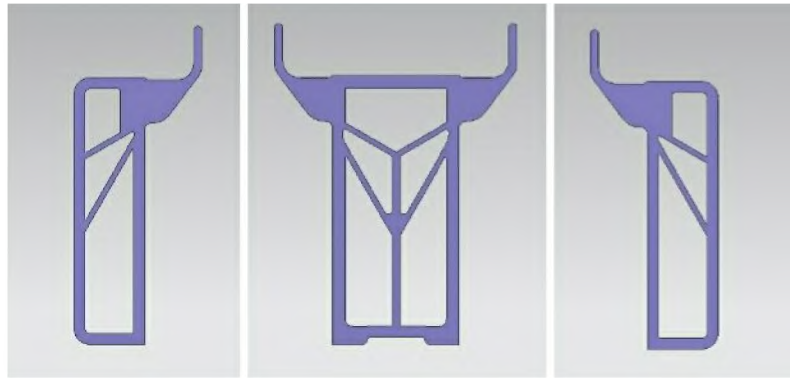

Fig. 5 - Sub-preforms

For the manufacture of sub-preforms by the method of Tailored fiber placement the fiber placement path was written in Unigraphics NX software (Fig. 6a). After that, the stitches for the specialized Tajima machine were assigned to the Adobe Illustrator program in the Carbon Layer module (Fig. 6b).

In order to effectively use the bionic design in the design of the hatch, the fiber placement path was designed so that the embroidery head of the Tajima machine laid composite fiber over the entire area of the hatch sub-preform in one technological operation. Due to this arrangement of the fiber, the load attributable to the bracket is evenly distributed over the entire area of the hatch sub-preform. The use of bionic design in the design of the hatch allows you to design a form in which the material is used only in loaded places, which allows to simplify the design of the part and save the costly composite fiber.

According to the specified settings and written trajectory, the specialized machine for directional fiber placement, Tajima, carried out automatic laying of the fiber on the base material (Fig. 7). For the manufacture of hatch sub-preforms, carbon fiber was chosen as the reinforcing fiber, since carbon fiber has high mechanical characteristics and low specific gravity. The composite fiber was laid on a water-soluble interlining, which, after the fiber lay-up process was completed, was washed out of the sub-preform with water.

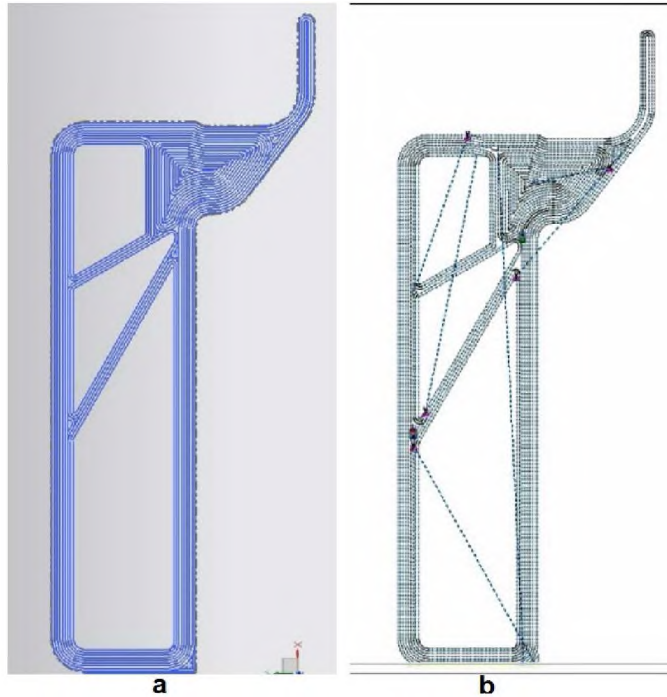

Fig. 6 - Writing the fiber placement path for the specialized Tajima machine:  
a- writing fiber placement paths in Unigraphics NX software; b – stitch assignment in Carbon Layer



Fig. 7. Sub-preform of the hatch, made on the equipment of Tajima for technology Tailored fiber placement

For the molding of the hatch of polymer composite materials, Resin transfer molding technology was chosen, since the designed part has a complex structure consisting of 3 sub-preforms that need to be connected to each other in the process of part molding. RTM

technology impregnates a part with a binder by the method of resin injection under pressure [4]. This technology allows you to mold parts of any complex shape, the molded part has a smooth surface on all sides and the optimum ratio of binder and reinforcing material. Using Unigraphics NX, we developed a tool for RTM molding of a part, the components of which are the matrix (Fig. 8a), the molding inserts (Fig. 8b) and the punch (Fig. 8c).

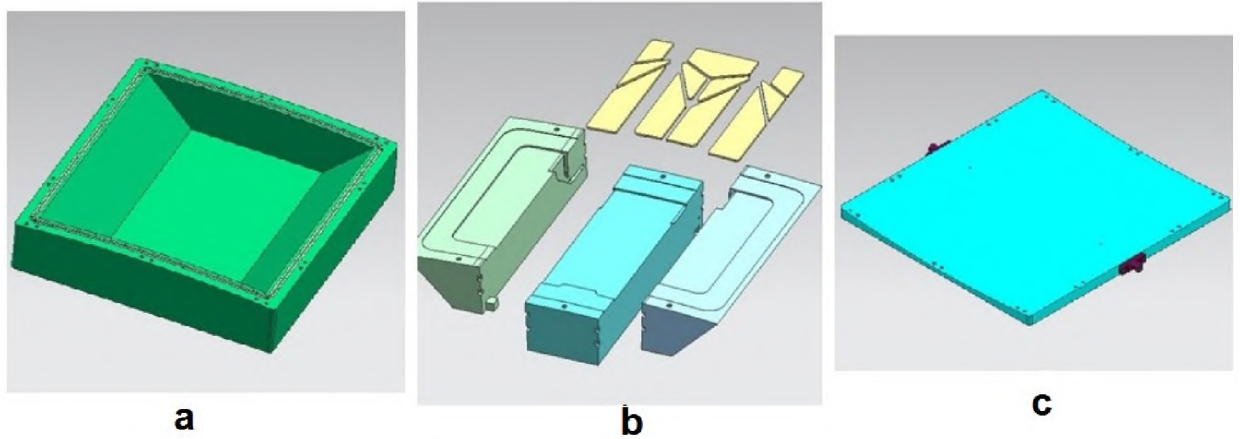

Fig. 8. Components of equipment for Resin transfer molding technology  
a – matrix; b – molding inserts; c – punch

Initially, preforms are installed on the surface of the molding inserts (Fig. 9).

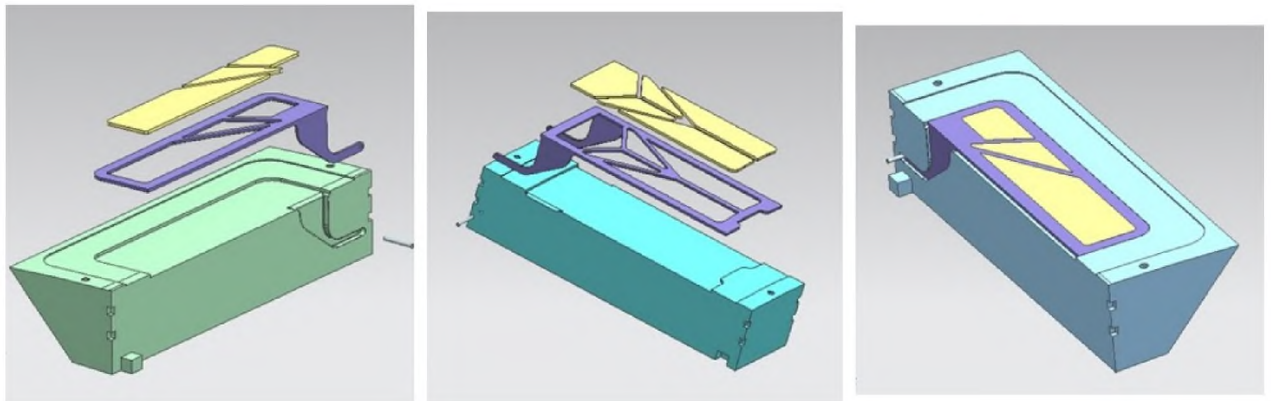

Fig. 9. Installation of sub-preforms on the surface of the molding inserts

The sub-preforms are based in the molding inserts, using pins installed in the holes of the brackets (Fig. 10).

After installing the sub-preforms, the inserts are connected to each other (Fig. 11a), then the composite fabric is laid out, which makes up the airframe of the future part (Fig. 11b). With the help of the eyebolts, molding inserts with the installed part are placed in a matrix (Fig. 11c), which is closed by a punch (Fig. 11d). The supply of the binder is carried out through a punch in which tubes for the input and output of the binder and a vacuum fitting are installed.

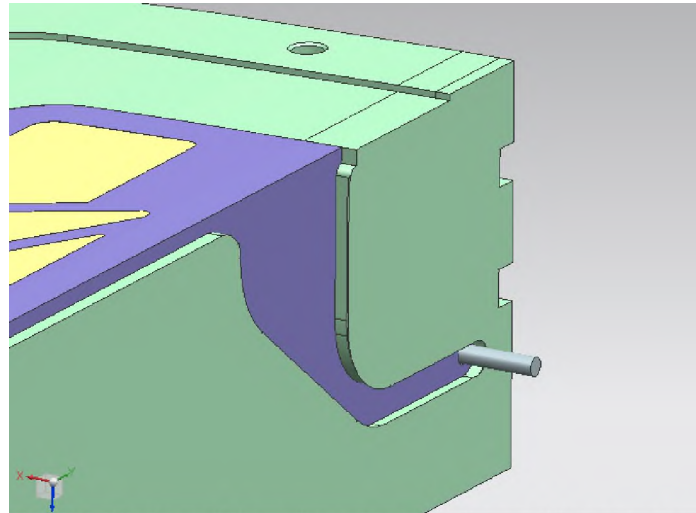

Fig. 10. Basing of the sub-preform in the molding inserts

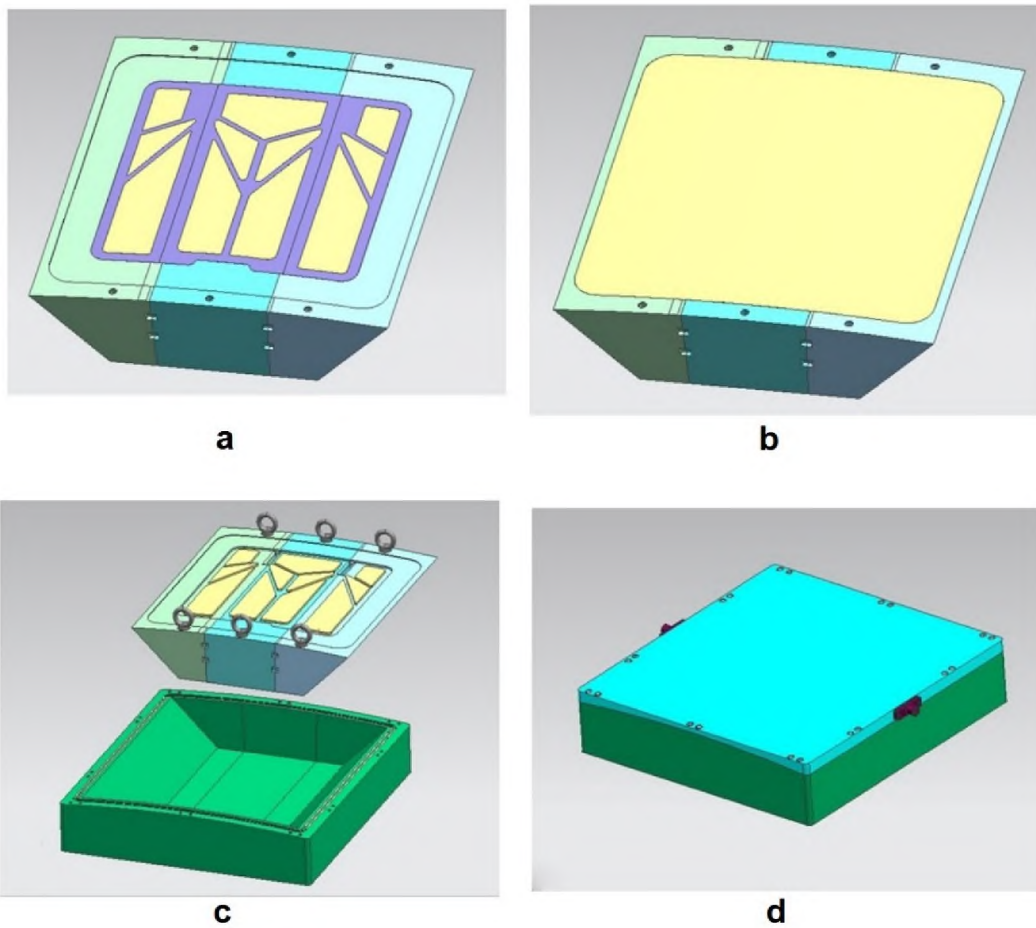

Fig.11 - Installation of parts in the mold tooling:  
a – joint with each other shaping inserts; b – installation of composite fabric;  
c – placement of inserts with installed part in the matrix; d – mold closing

## CONCLUSIONS

As a result of this study, a technology has been developed for manufacturing a hatch by the method of Tailored fiber placement, an electronic model of the hatch with bionic design was constructed and the tooling for Resin transfer molding technology was designed; also, the efficiency of using bionic design in composite parts was proven.

## REFERENCES

[1] <http://aviation21.ru/ms-21-lajner-s-chyornym-krylom/>

[2] <http://www.tailoredfiberplacement.com/>

[3] Konstantinov D., Khaliulin V., Batrakov V., Study of the possibilities of forming composite panels with an integrated framework, Kazan National Research Technical University. A.N. Tupolev, 2012

[4] <https://kompozit-sib.ru/tehsteklomet3.html>

## Authors



Daria Bezzametnova



Alexandra Kuzmina

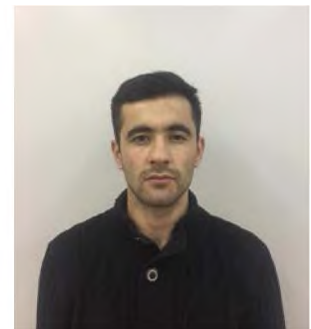

Fariddun Boboev

## DESIGNING AND MANUFACTURING PRIMARY LOAD CARRYING PARTS OF AIRCRAFT FROM COMPOSITE MATERIALS USING RADIAL BRAIDING

**Valentin Khaliulin, Alena Khudova, Ramazon Ysmonov**

Kazan National Technical Research University named after AN. Tupolev-KAI

Tolstoy street, 15

420012, Kazan, Russia

e-mail: [hudova-alena@mail.ru](mailto:hudova-alena@mail.ru)

**Key words:** Composite materials, Integral structures, Power bracket, Radial braiding, Robotic complex creation of preforms.

**Abstract.** *In our work, the auxiliary power unit bracket of the Mi-38 helicopter is analyzed in terms of its design and technological parameters, its relationship with other elements is described. Different versions of the bracket made of composite materials are illustrated; the best version of the composite bracket is selected. Prototype bracket is manufactured.*

Modern composite materials are widely used in aviation technology. Reducing the weight of the structure, increasing the strength characteristics, payload and service life due to the use of new materials increases the aircraft performance and reduces the cost of its operation [1].

In order to maximize the capabilities of composite materials, it is necessary to make it integral when designing a structure. An example of integral structures made of composites in the aircraft industry is the panels of the units and the frame elements of the aircraft Boeing 787 Dreamliner, Airbus 350, wing and tail of the MS-21 [2, 3]. However, the question of creating hinge fitting and brackets made of composite materials that will surpass the metal counterpart in its design and technological characteristics is on the agenda.

At the exhibition Jec Composite, which is held in Paris every year, you can see the integral connecting elements (Fig.1-3). However, the manufacturing technology of integral parts made of composite materials is a secret.



Fig.1. Rocking chair preform made of composite material



Fig.2. Components of composite materials

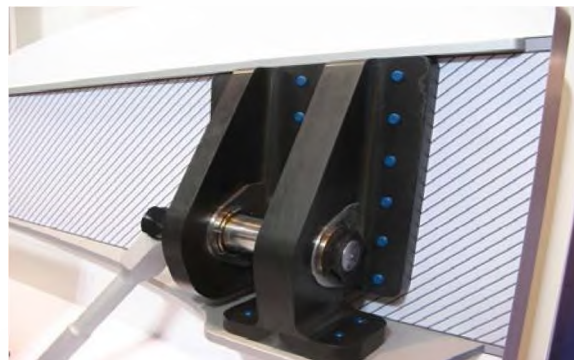

Fig.3. Bracket for mounting chassis made of composite materials

The auxiliary power unit is located in the engine compartment and is fixed to the ceiling of the helicopter's fuselage with eight bolts using an all-metal bracket and using attachment points to the power plant itself (Fig. 4).

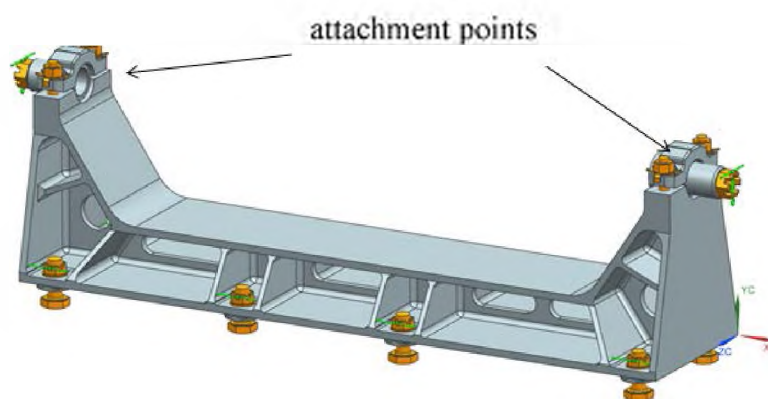

Fig.4. Auxiliary power bracket



Options for design solutions of the bracket made of composite materials:

1. Material: carbon fiber, the preform is made by hand lay-up (Fig.5).

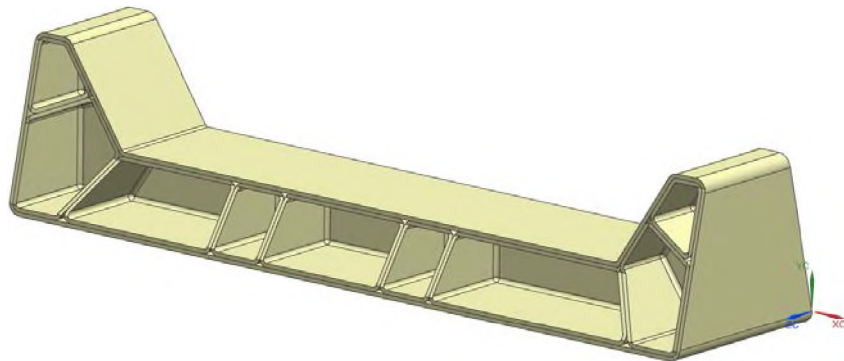

Fig.5. Bracket model, preform – hand lay-up

2. Material: carbon fiber, the preform is made by braiding (Fig. 6).

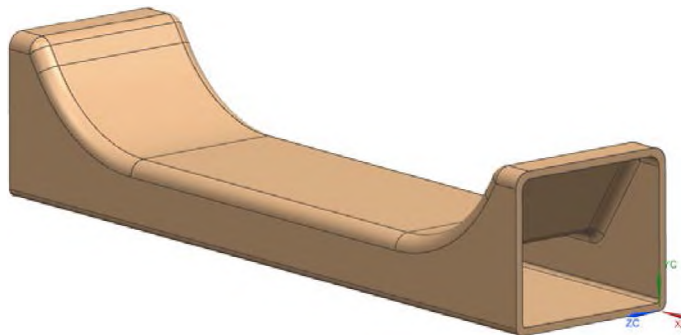

Fig.6. Bracket Model, preform –braiding

3. Material: carbon fiber, the preform is made by braiding (Fig. 7). However, it has differences in design from the previous version.

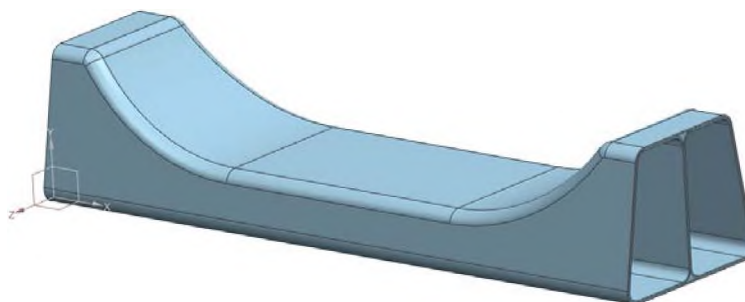

Fig.7. Bracket Model

Designed options for mounting the composite body to the panel of the helicopter (Fig.8).

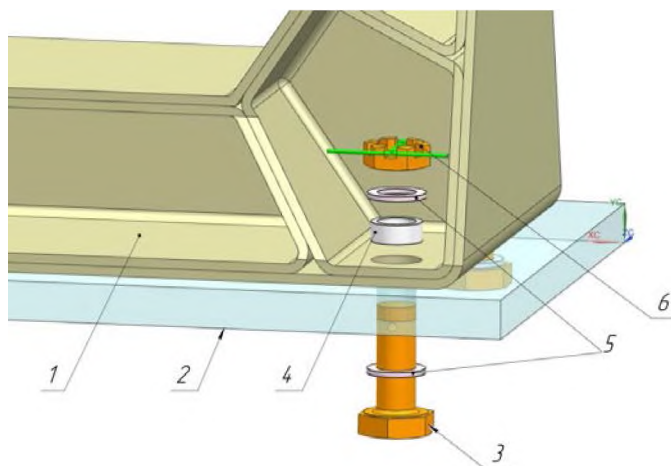

Fig.8. Exploded view of the bolt connection of the helicopter panel: 1 – composite body, 2 – helicopter panel, 3 – bolt, 4 – metal bushing, 5 – washer, 6 – crown nut

Option bracket, which was chosen for the manufacture of a prototype:

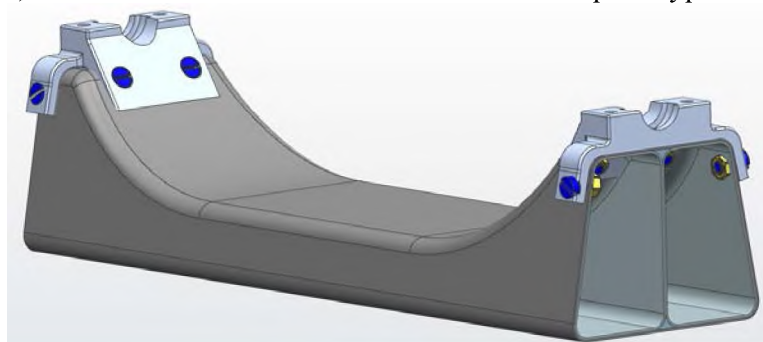



Fig.9. Model bracket for production

The weight of the metal bracket and the weight of the two options for brackets made of composite materials are presented in table 1:

Table 1. Mass of construction

Model			
Mass, kilograms	3,53	1,16	1,245

As can be seen from the table (2.1) of the calculated data, in both composite versions of the design it was possible to reduce the mass: in the first model by 68%, in the second by

65%. The density of the carbon fiber was taken to be approximately  $1.700 \text{ g / cm}^3$ . The density of steel fasteners  $7,700 \text{ g / cm}^3$ .

We choose the best option and develop the technology for its manufacture.

The bracket preform is made using a robotized complex for creating preforms using the radial braiding method HERZOG RF 1 / 144-100 (Fig.10).



Fig. 10. Robotic complex creation of preforms by the method of radial braiding.  
Conducting the experimental part.

The process of radial braiding consists of the following steps:

1. Application to the forming mandrel of the separation composition
2. Writing a control program
3. Charging HERZOG RF 1 / 144-100 with reinforcing material
4. Getting preforms
5. Fixing stocking on the mandrel

The mandrel for creating the preform is as follows (Fig. 11) :

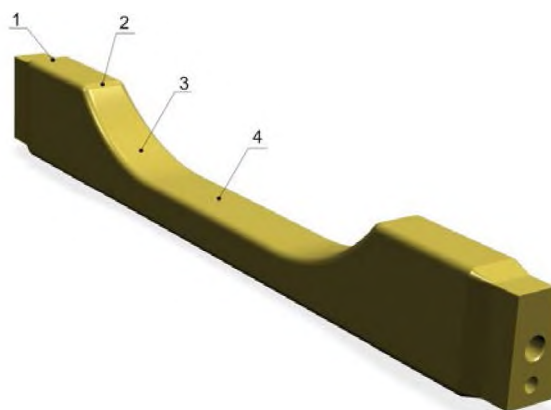

Fig.11. Transition zones

The prototype bracket is shown in Fig.12.  
Analysis of the result.

1. There was a gathering of fibers in the corner zones.

This problem can be solved by changing the trajectory of the mandrel in the area of radial braiding. It will coincide with the shape of a variable cross section.

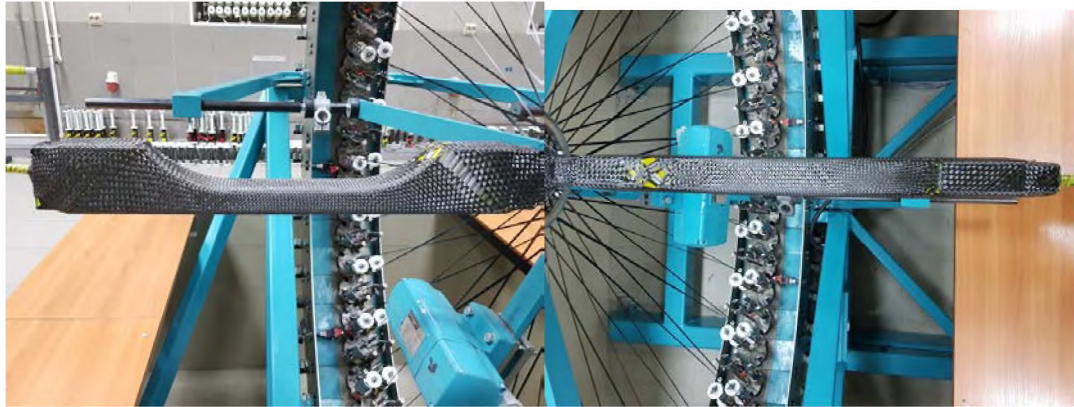

Fig.12. Bracket Preform

## REFERENCES

[1] V.I.Khaliulin, L.I. Shabalin. Introduction to the production technology of composite structures: Tutorial. Kazan: Composite Class, 2017. -104 p.

[2] V.I.Khaliulin, I.I. Shapaev. Manufacturing technology of composite products: Tutorial. Kazan: Publishing House Kazan.Gos. Techn., 2004.

[3] Polymer composite materials and manufacturing new generation technologies: materials of the II All-Russian Scientific and Technical Conference (Moscow, November 30, 2017), [Electronic resource] / “VIAM”. - M.: VIAM, 2017. - 295 p.

## Authors



Valentine Khaliulin



Alena Khudova



Ramazon Ysmonov

## INVESTIGATION OF CONSTRUCTIVE-TECHNOLOGICAL SOLUTION OF MULTI-WALLED CONSTRUCTION

Venera Sakhbutdinova, Elena Petrunina, Ramazon Usmonov

Kazan National Research  
Technical University named after A. N. Tupolev – KAI  
Tolstoy street, 15  
420012, Kazan, Russia,  
e-mail: e-petrunina96@mail.ru

**Key words:** Multi-walled construction, foam filler, Multi-walled panel.

**Abstract.** *In the presented work, a multi-walled construction with foam filler is designed to increase the heat and noise insulation properties. Samples were made and strength tests were carried out for longitudinal and transverse bending, as well as longitudinal compression.*

In the world today, composite materials are widely used in military and civil aircraft industry and aerospace industry due to their excellent strength, stiffness and lightweight in comparison with conventional materials. By lightening the design of the aircraft, cost-effectiveness is improved. For that reason, the development of various types of panels for aircraft parts will be relevant for long period of time [1-2].

Multi-walled construction with lightweight foam filler is an interesting topic to investigate [3-4]. This theme is actively developing overseas. The development of the German aerospace center within the project HGF “Black Fuselage” (Fig. 1) is a clear example.



Fig.1. The development of innovative fuselage within the project HGF “Black Fuselage”

With regard to the relevance of this topic, the authors decided to make samples of multi-walled panel and compare them with honeycomb sandwich panels.

Multi-walled panel is shown on Fig.2, which includes a foam filler mandrel position 1, which is wrapped by carbon fiber position 2, carbon fiber tow position 3, and skin position 4. Samples were manufactured using prepreg technology Fig.3 and vacuum infusion Fig.4.

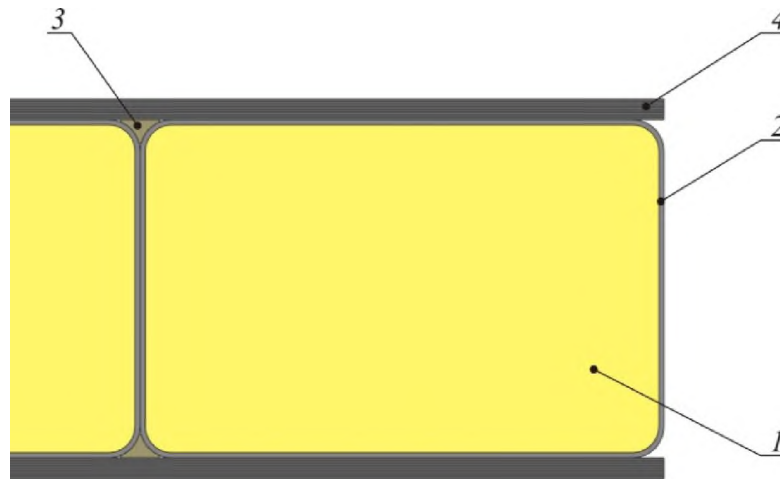

Fig.2. Multi-walled panel

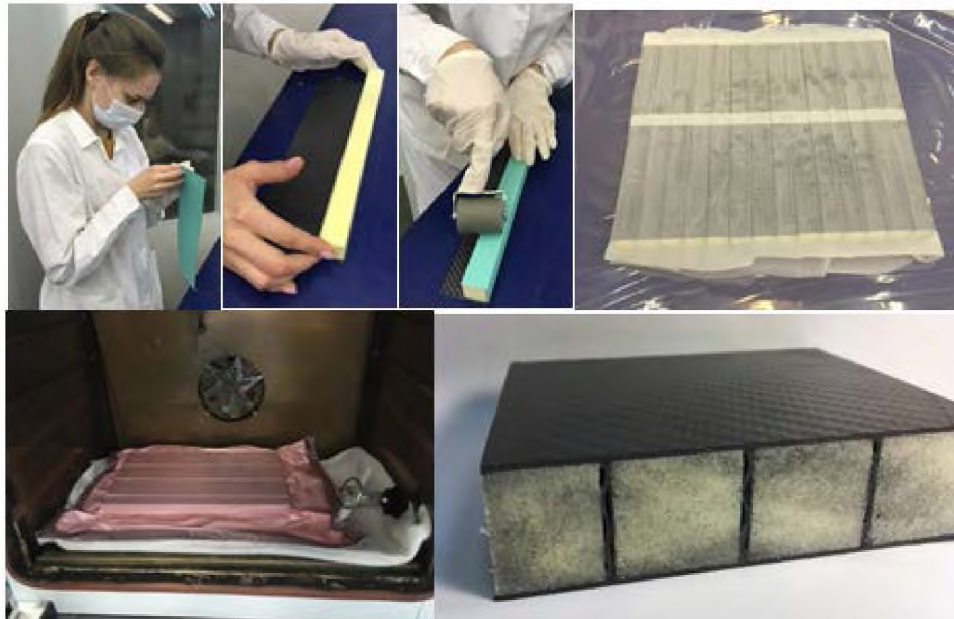

Fig.3. Manufacturing sample using prepreg technology

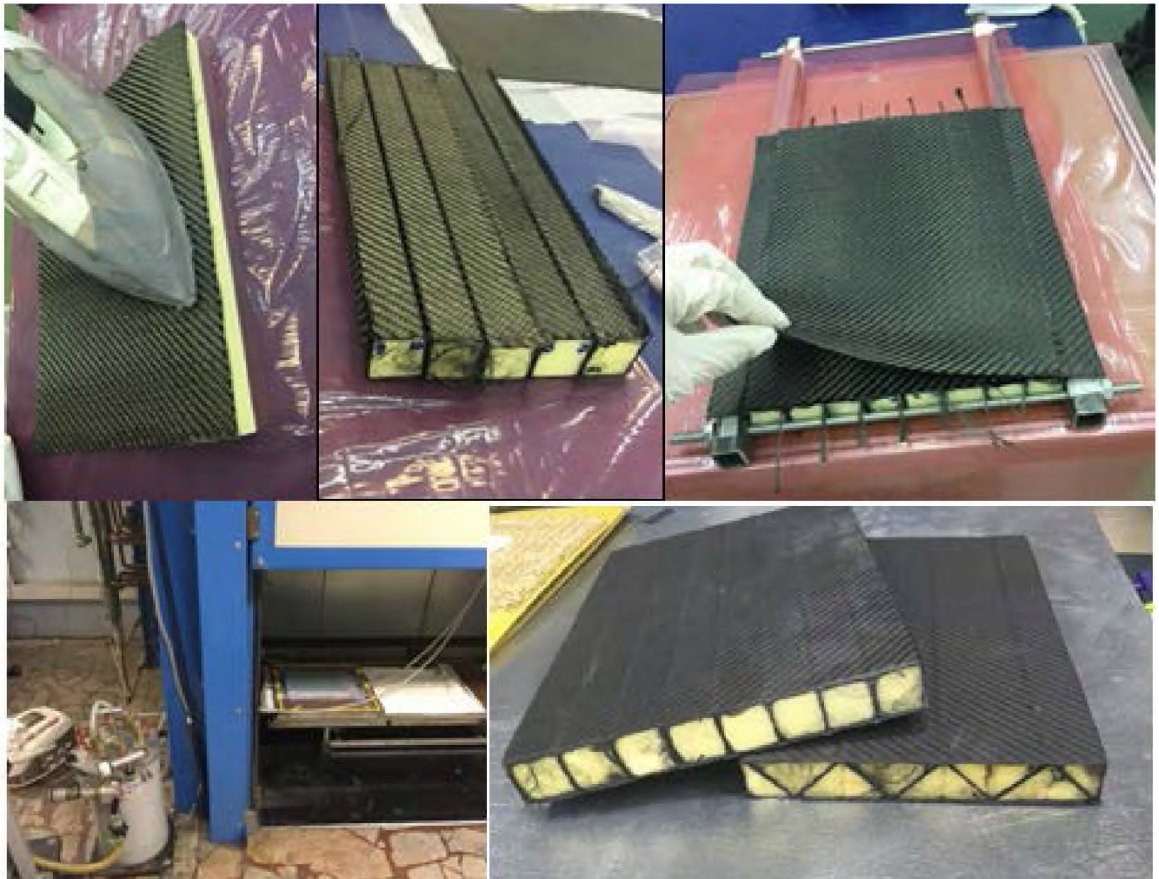

Fig.4. Manufacturing sample using vacuum infusion

After the manufacture of multi-walled panel tests were carried out for longitudinal and transverse bending, as well as longitudinal compression (Fig.5).

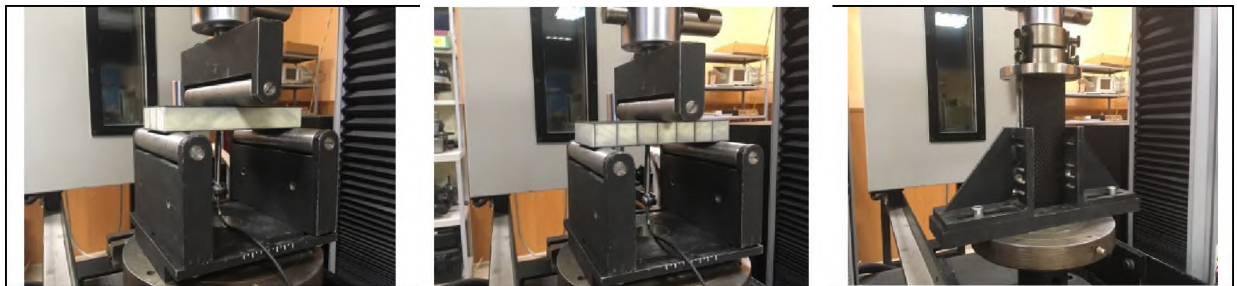

Fig.5. Testing of samples

Samples of a multi-walled panel were compared with samples of a honeycomb structure of the same thickness. Honeycomb density was selected similar to density of foam filler. Table 3 shows the maximum values of the physic-mechanical characteristics of the samples, under normal conditions.

Table 1. The results of the physico-mechanical characteristics of the samples, under normal conditions

N	Test title	Standard	Sample	Weight, g	Test results, MPa	$\sigma/m$
1	Longitudinal bending strength $\sigma_f^+$ , GPa	ASTM C 393-00	Multi-walled	85	36.454	0.43
			Honeycomb panel	62	10.584	0.17
2	Transverse bending strength $\sigma_f^+$ , GPa	ASTM C 393-00	Multi-walled	85	10.921	0.13
			Honeycomb panel	62	10.584	0.17
3	Compressive strength $\sigma_b^-$ , GPa	ASTMC 364-99	Multi-walled	80	36.377	0.45
			Honeycomb panel	62	11.703	0.19

To sum up, the multi-walled construction surpassed the honeycomb in terms of longitudinal bending and compression, however, the honeycomb construction works better on transverse bending.

## REFERENCES

- [1] Jin Zhou // The Energy-Absorbing Behaviour of Novel Aerospace Composite Structures // Thesis submitted in accordance with the requirements of the University of Liverpool for the degree of Doctor of Philosophy. – 2015 – P. 276
- [2] Pedram Sadeghian // Experimental and analytical behavior of sandwich composite beams: Comparison of natural and synthetic materials // Pedram Sadeghian, Dimo Hristozov and Laura Wroblewski // Journal of Sandwich Structures and Materials 0(00) – 2016 – 21 P.
- [3] Anil Uzal // A composite sandwich plate with a novel core design // Anil Uzal, Fazil O. Sonmez, Fatih E. Oz, Kenan Cinar, Nuri Ersoy // Composite Structures– 2018 – 33 P.
- [4] Jamal Arbaoui // Modeling and experimental analysis of polypropylene honeycomb multi-layer sandwich composites under four-point bending // Jamal Arbaoui, Hassane Moustabchir, Catalin I Pruncu and Yves Schmitt // Journal of Sandwich Structures and Materials 0(00) – 2016 – 19 P.

## Authors



Venera Sakhbutdinova



Elena Petrunina



Ramazon Usmonov



# THE MAJOR CONTENT OF THE CURRICULA ON THE AIRPLANE DESIGNING DIRECTION IN NATIONAL AEROSPACE UNIVERSITY KhAI

**Dmytro V. Tiniakov**

Nanjing University of Aeronautics and Astronautics  
College of Civil Aviation  
Jiangjun Ave., 29  
211100, Nanjing, China  
e-mail: [tinyakov\\_dm@mail.ru](mailto:tinyakov_dm@mail.ru)

**Key words:** Aircraft design, training methodology, syllabus.

**Abstract.** *The paper contents some information about major Aircraft designing content in the National Aerospace University of Ukraine. The civil aviation has trends to increasing of the production different kinds of airplanes. Here it is present some approaches: creation of a new projects or variants of also existing airplanes. But, more important specific that international cooperation grows year per year and will be growing in future. This fact creates specific requirements for aviation engineers, workers and another stuff that all of them must have approximately same level of knowledge and skills. But different countries have different educational traditions and approaches, which often very various. It is may create conditions for the limits creation before the international cooperation. So, the research and adjusting of the teaching programs about the aircraft designing in different universities are actual task.*

## 1. INTRODUCTION

The civil aviation has trends to increasing of the production different kinds of airplanes [1,2]. Here it is present some approaches: creation of a new projects or variants of also existing airplanes.

But, more important specific that international cooperation grows year per year and will be growing in future [3]. This fact creates specific requirements for aviation engineers, workers and another stuff that all of them must have approximately same level of knowledge and skills.

Different countries have different educational traditions and approaches, which often very various. It is may create conditions for the limits creation before the international cooperation. Analysis of universities educational programs can help to understand what future problems may be and how them can solve.

## 2. EDUCATIONAL PROGRAM OF THE NATIONAL AEROSPACE UNIVERSITY

In University this major is base and was found in 1930 year. So, University's experience in this major training is very deep. The responsible department for this major is Department of Airplanes and Helicopters Design.

The major in modern time is divided into two degrees: bachelor and master. Both of them will be explain separately.

In first it will be explain Bachelor degree [4]. Base education for the admission to the University for the Bachelor Degree is usually secondary education.

The total number of the courses is 55. They are included Russian or English languages physics, mathematics, etc. The total number hours is 7 200 include self-guiding and credits ECTS – 240.

For the specific professional courses the total number of courses is 40. From them:

- Full theoretical hours are 1008;
- Full practical hours are 585;
- Full laboratory hours are 585;
- Total self-guided training hours are 2 637;
- Total numbers of credits ECTS are 160.5.

This distribution is shown in Fig. 1.

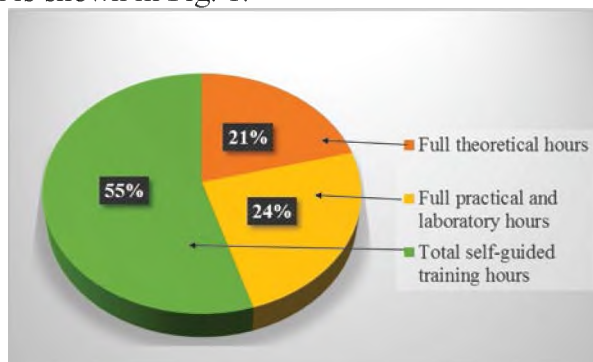

Fig. 1. Total hours distribution by theory, practice and self-guiding

It is interesting to understand about the distribution of these hours and credits between different groups of courses.

So, they can be divided by these way:

1. Aerohydrodynamics and Flight dynamic (include Thermodynamics);
2. Mechanics of Materials and Structures;
3. Airplanes Manufacturing Process (include Interchangeability);
4. Engineering Mechanics;
5. Aircraft' Systems and Equipment (include engines);
6. Engineering Materials Science;
7. Engineering, Computer Graphics, CADs, etc. systems;
8. Designing of airplanes (include all subunits and subsystems);
9. Airplane's operation and servicing.

The distribution of hours and credits presents in Table 1 and Figure 2.

So, now it is seen full hours distribution and it is possible to start for their analysis.

As it is seen in Figure 1 main part of the training is self-guiding. It is understand because amount of the engineering knowledge in modern time so much and they are very

complex. It is not possible to deliver full volume of them in time of official classes. And in future, I think, their volume will be growing.

Table 1. Hours and ECTS credits distribution between groups of courses

Line number	Name of the group	Lecture hours	Practical class hours	Laboratory class hours	Total class hours	Self-guided training hours	Total hours	ECTS credits
1.	Aerohydrodynamics and Flight dynamic	144	38	49	231	309	540	18
2.	Mechanics of Materials and Structures	175	149	40	364	386	750	25
3.	Airplanes Manufacturing Process	111	28	68	207	273	480	16
4.	Engineering Mechanics	123	121	34	278	337	615	20.5
5.	Aircraft' Systems and Equipment	66	–	47	113	127	240	8
6.	Engineering Materials Science	99	–	92	191	229	420	14
7.	Engineering, Computer Graphics, CADs, etc. systems	67	144	105	249	404	720	23
8.	Designing of airplanes	195	74	153	422	508	930	31
9.	Airplane's operation and servicing	28	–	28	56	64	120	4

Thereby, the significance of the self-guiding is very high and it dependences from two factors:

- 1) Students potential;
- 2) Specific training materials for the self-guiding.

The task for the professors to create required training materials for students with certain level of deep and convenience for their applying.

The distribution between theoretical and practical classes approximately same (21% and 24% correspondently). It is correct because without theoretical knowledge it is impossible to do any correct operation. The main task of practical and laboratory classes is to give for students practical skills for real operational procedures for designing, drawing, structural calculations, engineering analysis, etc. Without these practical skills the engineer can not be useful and successful.

About analysis of the hours distribution between courses groups. They are have approximately equivalent proportion. But it seen, that two groups have extremal dispersion. The Airplanes operation and Servicing has only 2 percentages, the Mechanics of Materials and Structures – 19 percentages.

All another different groups have about average value 10%. It is show that designer engineer must know not only “directly design” specifics of an airplane, but also and specific of its manufacturing, aerodynamic performance, structural materials features, etc.

If it is come back to Airplane`s operation. I think, it is good way to improve this distribution in better proportion. Because, operation and servicing of an airplane take biggest part in future airplane applying.

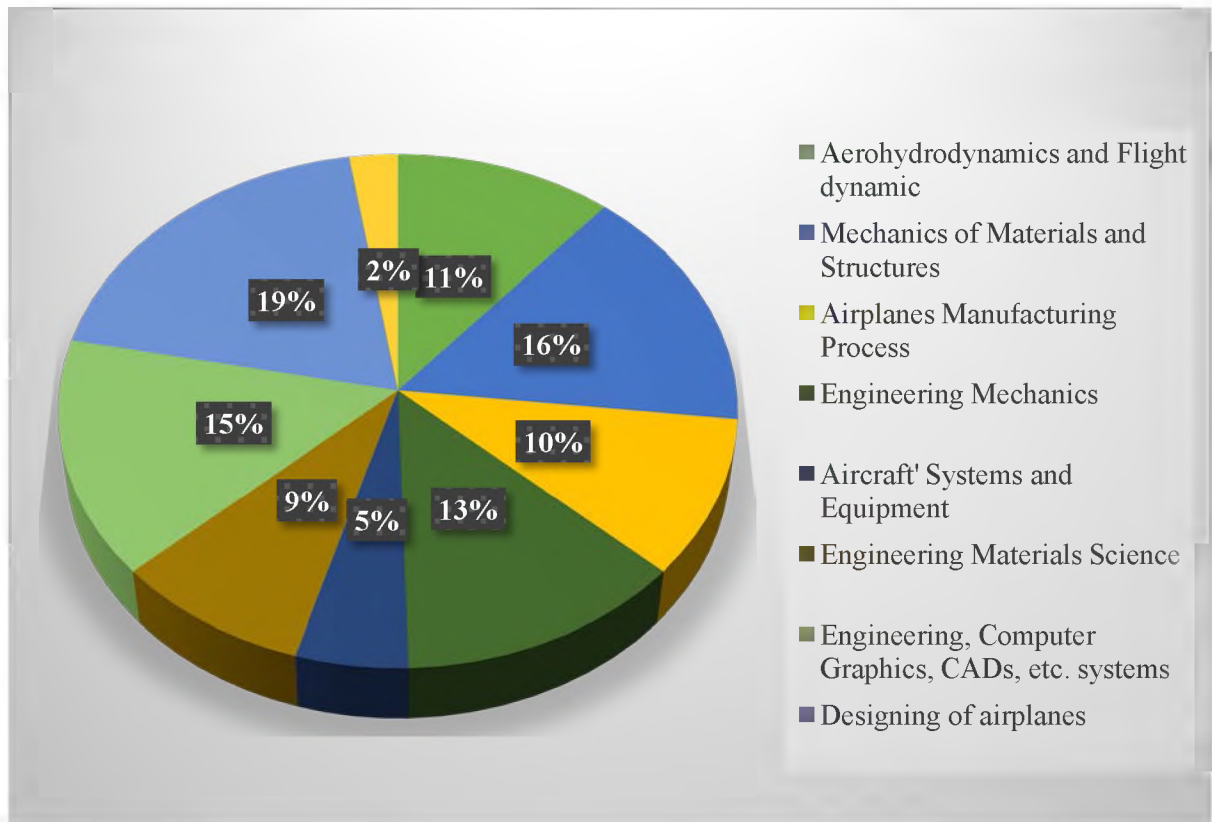

Fig. 2. Hours distribution between groups of courses

About the Mechanics of Materials and Structures courses. The main requirements, which are regulates by states and ICAO, are safety requirements for aircraft operation. This group of courses directly relates and provide them. Thereby, they have so much percentages, and if we add here and the Engineering Mechanics courses (13%), we can obtain 32 % in general. And this result clear shows that safety is very important in time of an airplane designing.

About contents of practical and laboratory classes. In practical classes, students solve different kinds of engineering tasks, which relates to the course topic. In laboratory classes, students obtain real practical skills for the experiments creation; they operate with real equipment, etc.

Biggest part of these courses have course project. The main aims of them is to give for students real opportunity for the themselves engineering solving under adviser control.

But this explanation of the next paper.

### 3. CONCLUSIONS

The proposed research shows:

- the total number of the professional courses is higher than general educational courses;

- theoretical classes and practice (include laboratory classes) have approximately same volume;
- self-guiding is major part of the training, because it takes more than 50 % from the total volume of hours;
- different groups of courses have approximately same hours distribution;
- some disproportion in courses groups (Aircraft systems and equipment courses have about 5 %) can be compensate by content in other courses or by redistribution of available hours.

Moreover, because the self-guiding has so much volume it is needed to prepare high level additional materials for its support, like books, data bases, web-sources, etc.

## REFERENCES

- [1]. Global Market Forecast 2018-2037, Airbus S.A.S., France, 2018.
- [2]. Boeing Forecasts. Aviationnews.eu, <http://aviationnews.eu/>, 2018.
- [3]. Drogovoz P.A., Khrusheva V.A. Analysis of international production cooperation in the Russian aircraft industry. Engineering Journal: Science and Innovation, is. 68, 2014.
- [4]. Syllabus for the major Aircraft Designing of the National Aerospace University, 2016.

### Author



Dmytro TINIAKOV

## REVIEW OF PROBLEMS OF ENSURING RELIABILITY OF FUEL SYSTEMS OF MODERN SUPERSONIC BUSINESS JET AIRPLANES

Anna Nechyporenko, Su Yan, Dmytro V. Tiniakov

Nanjing University of Aeronautics and Astronautics  
College of Civil Aviation  
Jiangjun Ave., 29  
211100, Nanjing, China

e-mail: [aniquav@yahoo.com](mailto:aniquav@yahoo.com), [tinyakov\\_dm@mail.ru](mailto:tinyakov_dm@mail.ru)

**Key words:** Reliability, fuel system, supersonic aircraft, business jet airplane.

**Abstract.** *The development of aviation, include supersonic civil airplanes, required new approaches for the designing of airplane's systems. Supersonic speeds allows to decrease the flight endurance, but they require more higher reliability of the powerplant systems like the fuel system. It was observed some issues of ensuring reliability of fuel system for supersonic business jet aircraft. The actual task is to determine the most common problems, which arise during the designing and operation of civil supersonic aircraft and in particular their fuel systems. It was shown some examples of solving these problems, which have previously used on other supersonic aircraft that have different purposes, as well as new ways to improve the reliability of the fuel system during the flight at supersonic speeds.*

### 1. INTRODUCTION

The safety is the most important problem of modern aviation. Consequently, the reliability of systems of aircraft is paramount [1]. One of the most important and significant system of the airplane is the fuel system. The primary function of the aircraft fuel systems is to provide a continuous source of fuel at the appropriate pressures and temperatures to the propulsion system (engines) throughout the aircraft flight envelope under normal operation and in the presence of failures. Fuel system need to be designed and arranged to provide fuel flow at a rate and pressure established for engine and APU functioning under each likely operating condition.

Even despite the fact that the world of aviation is moving towards to provide electrical systems on the plane, but still in the priority is supersonic speed, which can be achieved now only by powerful power plant with fuel. In this regard, not only clear technical requirements for the fuel system, but also the requirements for its reliability and uninterrupted operational supersonic flight speeds are increasing.

Analysis of the fuel system is the most important stage for the creation of the fuel system, from primary problems and ending with the appearance of design solutions for the system and elements of the system.

## 2. MAIN PART

### Objective

One of the most important purpose is to ensure the reliability of the fuel system at supersonic flight speeds. At these speeds on the plane occur some problems, such as:

1) Placement of fuel on the aircraft

As is known during the flight in supersonic mode, the aircraft consumes a huge amount of fuel. Because of the requirement of supersonic flight, the aircraft must have a very thin wing profile, long and thin fuselage and this have affects to the structural strength. All this imposes very serious restrictions on the placement of fuel in the structure.

2) Backward displacement of the pressure center at supersonic speeds

Supersonic aircraft fuel system, in addition for its main functions, is used also to rebalance the aircraft during the transition of the sound barrier.

### Research

Before the research, it is needed to consider solving of these tasks with general requirements for aircraft fuel systems [2]. There are:

- 1) Reliable fuel supply to the engine with the required flow rate and under the required pressure at all permissible operating modes of the aircraft and the engine;
- 2) Ensuring the safety and survivability of the system. For this purpose provided using fuel from any tank to any engine, the reservation of the most important units, the placement of intake compartments in the tanks, etc.;
- 3) Automatic production of fuel from the tanks to given sequence while maintaining the alignment of the aircraft in the allowable range;
- 4) Reliable, convenient and continuous monitoring of the fuel system operation on the ground and during the flight;
- 5) Protection of fuel system units from corrosion, freezing, microorganisms, static electricity discharges, overheating. Providing strength and vibration resistance;
- 6) Operational adaptability - adaptability of the fuel system to perform maintenance work with minimal cost.

#### *Placement of fuel on the aircraft*

For transport category aircraft, usually, passengers and cargo placed in fuselage. So, from the point of the required level safety providing in time of the emergency landing the fuel usually arranged in wing sections. This also has affect on the thickness of the wing's aerodynamic airfoil. In some cases, fuel tanks are located in the fin at the fuselage tip. Also, for the fuel is given only a part of volume of the wing, but otherwise the amount of the wing high-lift devices, landing gear and elements of the control system [3]. Let's have a look, how fuel placed in Concord:

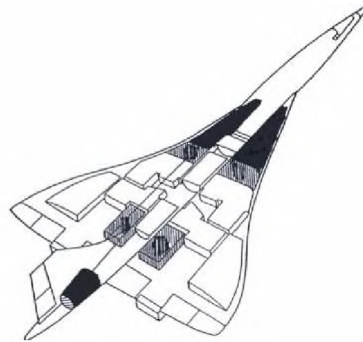

Fig.1. Placement of fuel in Concord

For the business jet, due to the limited volume of the aircraft wing structure we cannot place the required fuel amount as in Concorde. In this case, we can refer to the structure of fuel placement on supersonic fighters. In fighters, the bulk of the fuel placed in the fuselage and additionally in the wing. In addition, outboard fuel tanks applied for further increasing fuel reserves. The typical example of fighter fuel system shows in Fig.2.

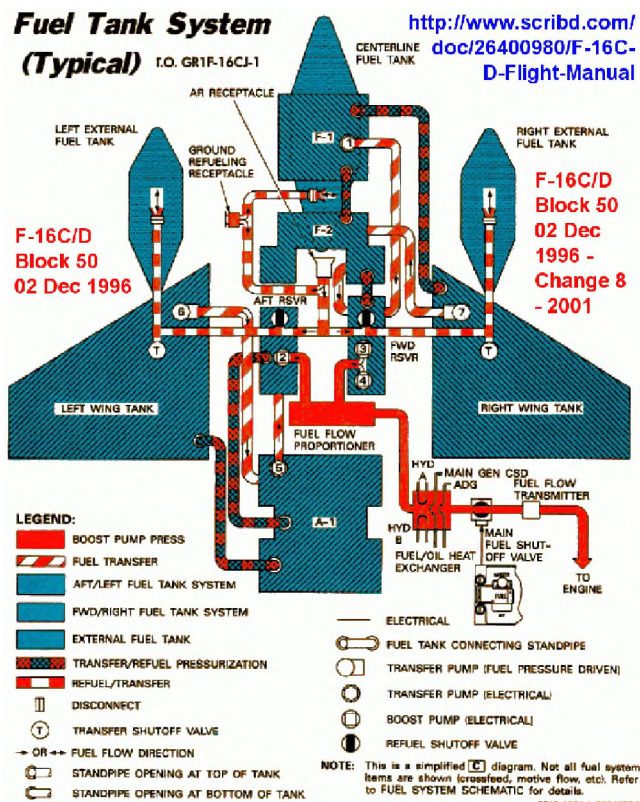

Fig.2. Typical example of the fighter F-16 fuel system

In the case of a business jet, it is useful to apply the wing extensions. Additionally, the wing extension can improve the aerodynamic performance of the supersonic airplane by reducing the wave drag, as well as actually increase the wing area, which consequently increases the storage space and the placement of the fuel. Disadvantages for the wing extension using can be heating of the fuel tank surface, cavitations, which can appear in fuel, and high possibility of the its damage in time of the take-off and landing.



To avoid the problem of the heating it is possible to use composite materials for the wing extension, which are more refractory. In the Fig.3, we can see the example of the Concorde wing shape and the temperatures distribution at its surface at speed 2 Mach number [4].

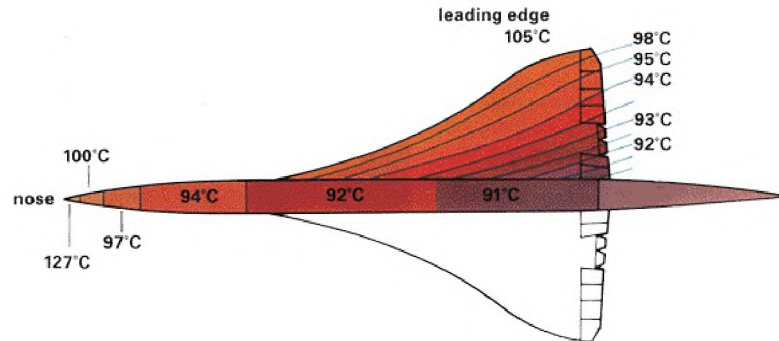

Fig.3. Concorde wing shape and the temperature distribution

The leading-edge wing extension has a high risk of collision with foreign objects (stones, birds, aircraft parts, etc ), which can lead to the destruction of the structure of the wing extension and consequently can become a reason of fuel leakage (Fig.4.).



Fig.4. Destruction of leading-edge wing extension in a collision with a foreign object

To solve this problem it recommends applying a protection, such as liquid rubber. This will not only increase of the reliability of this part, but also can help to decrease the fuel tanks heating.

By the way, we can use simpler methods to solve the problem of fuel placement. For example, recompose the structure of the wing of the aircraft, as well as to abandon the mechanical control system and replace it by fly-by-wire one. Since the mechanical control system takes up a lot of space in the structure of the wing, the fly-by-wire system will allow us to free up some place to accommodate the required amount of fuel.

#### *Backward displacement of the pressure center at supersonic speeds*

This problem is one of the important for all supersonic airplanes.

On the example of Concorde we can see how this problem of displacement of the center of pressure during the flight at supersonic was solved.

Center of lift for supersonic aircraft can move about 2 meters. On a traditional subsonic aircraft, the control surfaces usually can be adjusted by trim-tab to keep the aircraft balancing. However, for the supersonic aircraft this would become a cause of the high drag and of control losing of an aircraft at the supersonic flight speed. So, for Concord it had decided to compensate the change in the center of lift by moving the weight distribution by pumping fuel from the forward trim-tanks to the rear trim-tanks and vice versa (Fig.5) [5].

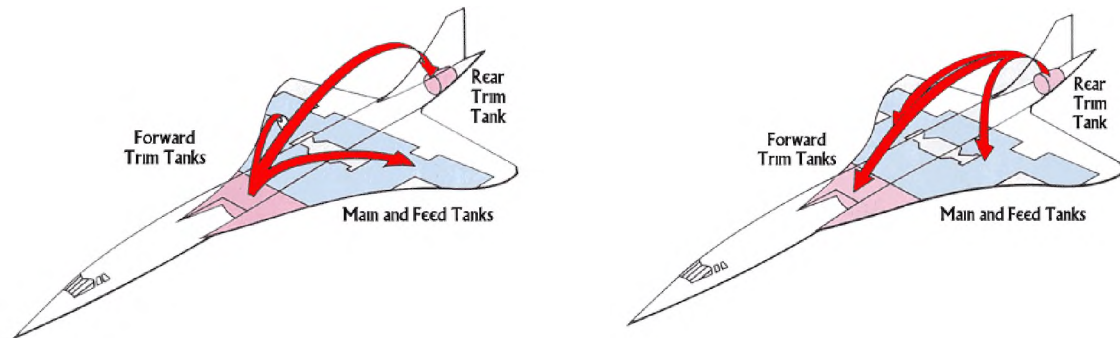

Fig.5. The scheme of pumping fuel in tanks in Concord

The concord has near 90 tons of the fuel. Therefore, by this way, it was rational solution for keeping balancing.

For the smaller supersonic airplanes, like fighters, this solution was also applied. But its efficiency was not so high.

The supersonic business jet has average weight between fighters and Concord, so we can say that the fuel system will be used for the airplane balancing. This is required from it additional reliability, because pumps must have power, which must to provide fuel motion not only in engines, but also between different fuel tanks. It may be solved by the using some fuel pumps in fuel tanks. However, intensity of their operation can be controlled by the board computer system with the next proportion: the major pump will have power 75% from maximum possible, secondary – 25%. This way also to provide higher reliability. If one pump will failure than second can compensate its lost power.

The redundancy is main way of the reliability improving. It needs to find the compromise between additional weight and required reliability. However, this task is for my next research.

### 3. CONCLUSIONS

This paper relates with problems of the fuel system development for supersonic civil airplanes.

- 1) It was shown main problems for the development of fuel systems for business-jet airplanes.
- 2) Review of solutions for these problems was completed.
- 3) It was proposed that:
  - Wing extinctions are rational solution that can be applied for the business-jet airplane;
  - The protecting, which usually applied in fighters, will be useful for this type of civil airplane from the point of the heating prevent and also for the reliability increasing;

- The fuel moving in the flight time can keep the airplane balancing, but required additional equipment, which can increase the reliability of the fuel system in general.

Next stages of this research require deep analysis of the efficiency proposed here design solution and possibly combined them with other design solutions. In any cases only calculations, simulation and real tests can help to researches to obtain required level of the fuel system reliability for the supersonic business-jet airplane.

## REFERENCES

- [1] Y. Lemmens, L. Allain, T. Olbrechts, *Reliability analysis of aircraft system architectures*, LMS International, 2012.
- [2] Dr. Edmund Cichosz, *Supersonic aircraft: reference guide*, Warsaw, 1980.
- [3] <https://infopedia.su/7x638e.html>
- [4] <http://modelik.ru/2009-04-08-07-39-30/detail/4/654.html>
- [5] <http://www.concordesst.com/fuelsys.html>
- [6] Dr Derek Bray, Dr Nick Lawson & Simon Harding, *Supersonic business jet aircraft design*, ICAS CONGRESS, 2002

### Speaker



Anna Nechyporenko

## FEATURES OF THE USE TITANIUM ALLOYS IN THE CONSTRUCTION OF AEROSPASE SETTING

**Oleksandr Moliar<sup>1,2</sup>, Yao Zhengjun<sup>1,2</sup>, Zhang Shasha<sup>1,2</sup>, Liu Zili<sup>1</sup>,  
Miao Qiang<sup>1</sup>, Zhang Pingze<sup>1,2</sup>**

1- College of Material Science and Technology,  
Nanjing University of Aeronautics & Astronautics, Nanjing, 211106, China;  
2- Key Laboratory of Materials Preparation and Protection for Harsh Environment,  
Ministry of Industry and Information Technology, Nanjing, 211106, China  
e-mail: [molyar\\_olekandr@iua](mailto:molyar_olekandr@iua)

**Key words:** Modeling, Experimental and numerical mechanics, Education process.

**Abstract.** *In this paper, going is presented near constructing of details and aggregates of aviation from titanium alloys. It is shown that advantages of titanium alloys show up at the account of all complexes of their properties - physical, chemical, mechanical, technological and operating. The certain examples of airplane constructions are presented, where advantages of titanium alloys show up as compared to other materials*

### 1. INTRODUCTION

Using of titanium alloys as construction material in aviation industry, determined by the unique complex of their physical, chemical, mechanical, technological and operational properties. For titanium alloys, as construction material, next advantages are characteristic as compared to traditional - by steels, aluminum and magnesium alloys (Fig.1):

1. High specific strength and her insignificant changes within the limits of "middle" temperatures (from  $-60^{\circ}\text{C}$  to  $+500^{\circ}\text{C}$ ).
2. High temperature of melting ( $1668^{\circ}\text{C}$ ), high enough firmness to oxidization at the brief intensive heating, chemical stability to the products of burning of fuel, low thermal conductivity;
3. The lowest rate of coefficient of thermal expansion among well-known construction materials ( $\alpha_{\text{titanium}} = 9,3 \cdot 10^{-6} \text{ degree}^{-1}$  in an interval 293-723 K);
4. Low elastic module ( $E=120\text{GPa}$ );
5. Low heat conductivity. Coefficient of heat conductivity of titanium  $\lambda=21.9 \text{ W/m degree}$ ;
6. Very high corrosion resistance of titanium practically in all aggressive environments, that there are in the operation of aircraft of - most of mineral and organic acids, solutions of lyes etc;
7. High enough resistance to dust erosion to the abrasive wear;
8. A high manufacturability of the little alloyed alloys is good weldability by practically all types of welding, capacity for hot and cold deformation, that allows to make with large exactness of sizes of detail of complex geometry form.

## 2. MAIN PART

We will consider some examples of application of titanium alloys, taking into account features of their physical, chemical, mechanical, technological and operational properties.

Table 1. Comparative characteristics of aviation materials

Material	Density $d$ , kg/m <sup>3</sup>	Tensile strength $\sigma_B$ , MPa	Elastic module $E$ , GPa	Specific strength, $\sigma_B/d$ , km	Specific stiffness $E/d$ , km
Aluminum alloys	2700	400-650	72	14.8-24.0	265
Magnesium alloys	1800	200-340	45	11.0-18.9	250
Titanium alloys	4500	500-1450	120	11.0-32.2	266
Middle strength steel	7800	800-1300	210	10.3-16.7	270
High strength steel	7800	1300-2300	210	16.7-29.5	270
Composites	1400-2600	500-1300	35-250	40-60	250-1000

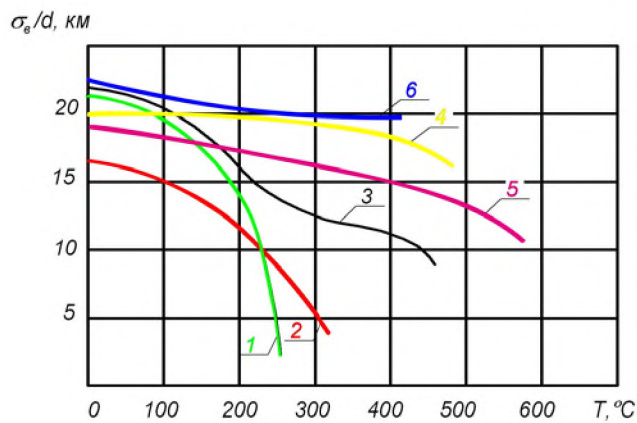

Designations:

- 1- Aluminum alloy 2024;
- 2- Aluminum alloy 7075
- 3- Titanium alloy of TC6 (Ti - 6-4)
- 4- Construction steel of Fe - Cr - Mn - Si
- 5- Stainless high strength steel of Fe - Cr - Ni - Mo - Ti
- 6- Titanium alloy of TC18 (Ti - 5-5-5-3)

Fig.1. Dependence of specific strength ( $\sigma_B/d$ ) of construction alloys on a temperature (T)

Coming from the data, driven to Tabl.1 and Fig.1 high strength titanium alloys within the limits of "middle" temperatures have maximal specific durability among construction aviation alloys, that combines with a high corrosion resistant. It gives advantages to the titanium alloys in the power constructions of undercarriage, mechanization of wing and hydraulic system, where corrosion resistances of material are especially important, that facilitates maintenance of aggregates in exploitation and increases a resource. Some examples of making of power constructions from the high strength titanium alloys of are presented on Figs.2-5.

Researches executed the last years, including in China (alloy of FT - 01) showed that the generally accepted tensile strength for high strength titanium alloys  $\sigma_B = 1100 - 1300$  MPa can be substantially increased to  $\sigma_B = 1350 - 1500$  MPa without the decline of plasticity and to  $\sigma_B = 1500 - 1700$  MPa at some decline of plasticity, if it is succeeded to provide the receipt of fine-grained (size of grain about 1-5  $\mu\text{m}$ ) globular structure (Fig.6).



Fig.2 Stand of undercarriage of airplane from the alloy of TC18 (BT 22 or Ti-5-5-5-1-1.5)

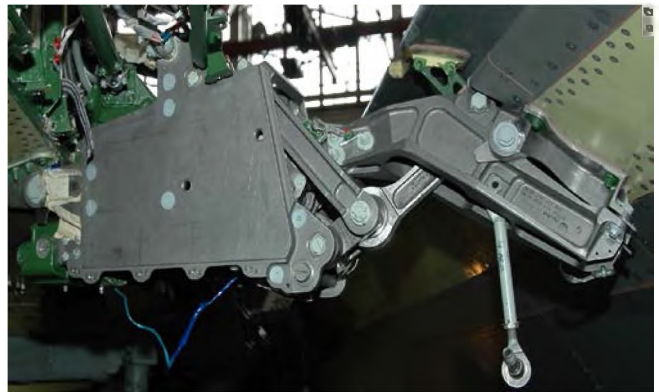

Fig.3. Power brackets of mechanization of wing from the alloy of TC18



Fig.4. Rail of control system of flap airplane AN 124 "Ruslan" from the alloy of TC18



Fig.5. Titanium components wares of hydraulic of airplane:  
*a*-hydraulic cylinder; *b*- stock of hydraulic cylinder; *c*- joint wiring of TC18

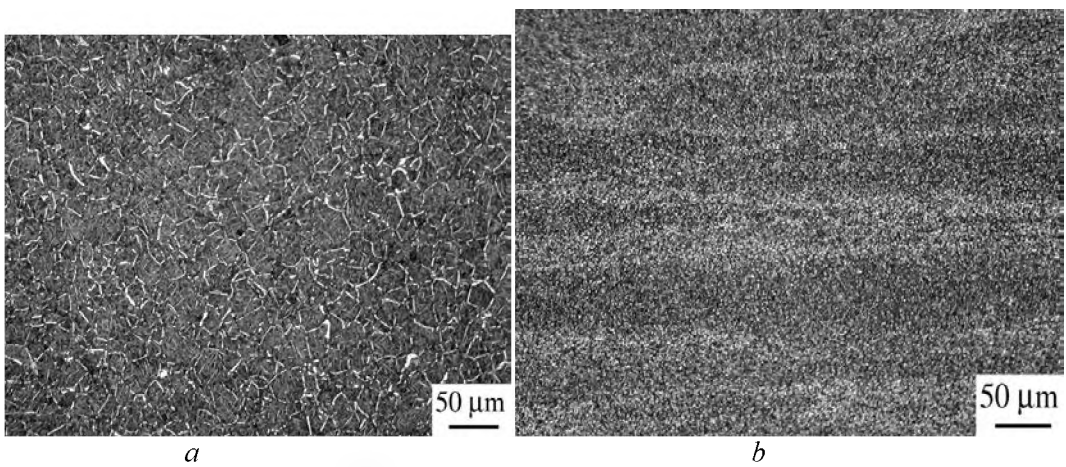

Fig.6. Microstructure of bar from an alloy FT-01: *a*- at standard technology of making;  
*b* - after the optimized modes of thermo mechanical treatment

The receipt of such properties allowed to make the timber details (screw-bolts) of Fig. 7, with the record value of specific durability for construction details  $\sigma_B/d=32\text{km}$  (the before used titanium roofing timbers had  $\sigma_B/d=23$  kilometers).



Fig. 7. Titanium screw-bolts from an alloy FT-01:  
*a* – after the hot landing heads of bolt; *b* – finally made.

Use of alloy TC18 in a state of heat treatment  $\sigma_B=1500 - 1700$  MPa allowed to make the corrosion-resistant springs of Fig. 8, efficiency of that on weight and volume is determined on dependences:

$$\text{Volume} = \frac{G}{\tau^2} \left[ \frac{2P^2}{R} \right]; \quad \text{Weight} = \frac{G\rho}{\tau^2} \left[ \frac{2P^2}{R} \right]$$

where:  $G$  is shear modulus;  $\rho$  is density;  $\tau$  is shear stress;  $R$  is spring rate;  $P$  is load.

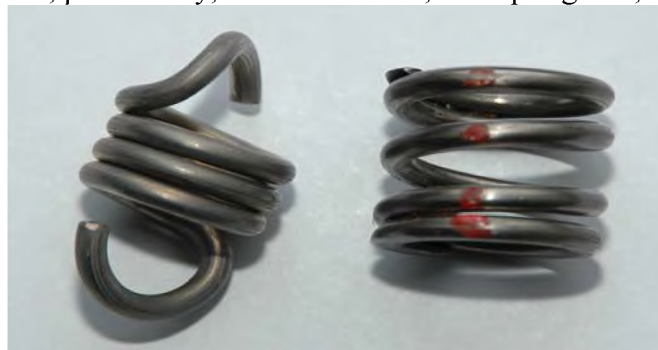

Fig. 8. Titanium springs of tension and compression from an alloy TC18

By the interesting example of the use of middle stress alloy of TC4 (BT6) (Fig. 9) there is his effective application for making of the weld-fabricated flooring of sexes of freight booth of heavy carrier where enhanceable erosive firmness of titanium alloys and firmness are taken into account to the abrasive wear. Traditionally floor of carrier was made from a high strength aluminum alloy 7075 (sheet with thorn or corrugate sheet - for providing of friction contact with a loading or transported technique), that has high not enough pin durability, wear resistance, erosive firmness and hardness. At the portage of heavy military technique it results in the premature wear of thorns and destruction of sheets. The alloy of TC4 has higher hardness and pin durability what not hardened steel, what the wear of flooring of sexes allows to minimize at a movable contact with the steel details of mechanisms for lifting loads and tracks of caterpillar technique at the loading and unloading airplanes. The use of the titanium flooring allowed substantially to increase the resource of flooring cargo floor, in particular during intensive commercial exploitation of



airplanes, that gives a considerable economic effect (absence of repairs), not looking on the higher cost of titanium alloys as compared to aluminum.

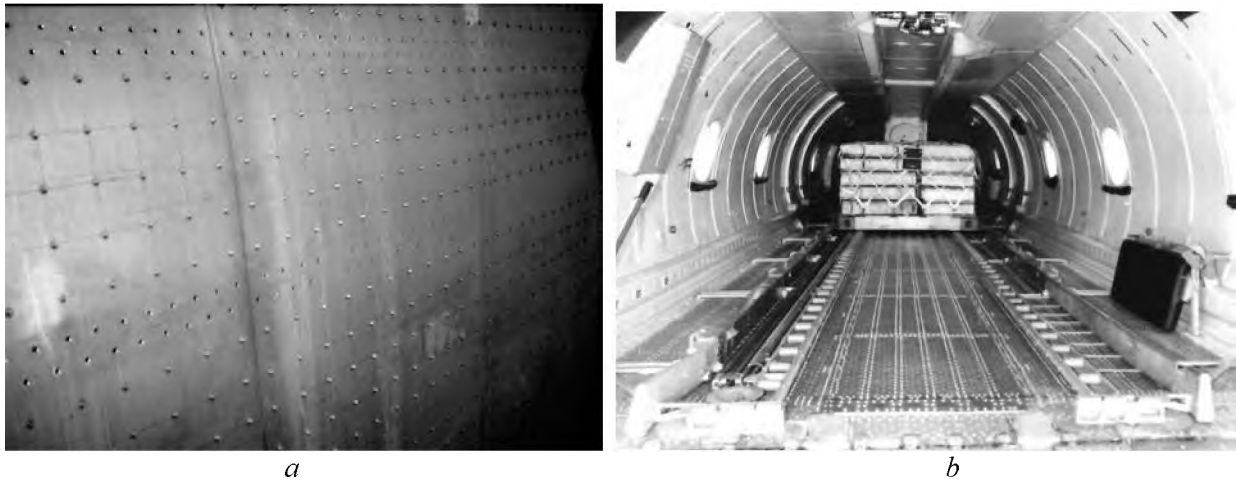

Fig.9. Titanium flooring of cargo floor of airplane of AN-124 "Ruslan":  
a- the weld-fabricated sheet with thorns; b- power floor in a freight booth.

High corrosion resistances and technological properties taking into account enhanceable wear resistance are used for making of mounts of doors and hatches of Fig.10. Moisture is always saved in these places of airplane, the thresholds of doors are exposed to the intensive wear, destruction of paint. In connection with the produced requirements on physical and chemical and to operating properties of mount can be made from corrosion resistance aluminium alloys, stainless steel or titanium alloys. Use of aluminium alloys for the indicated details in airplanes with the protracted calendar resource, problematic, foremost, from their low wear resistance and insufficient corrosion resistance. In addition making of difficult details from aluminium alloys is limited to their technological properties. Stainless steel lose to the titanium alloys on wear resistance and specific durability. The details from the littlealloyed titanium alloy of TA21 (Ti - 1Al-1Mn) will be very effective.

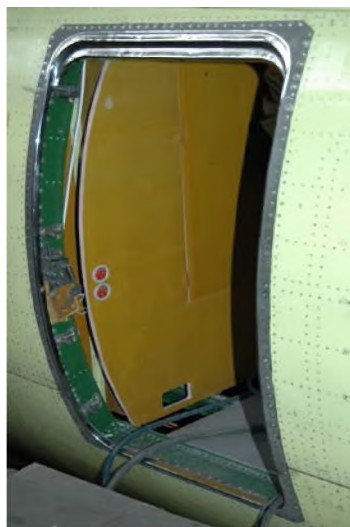
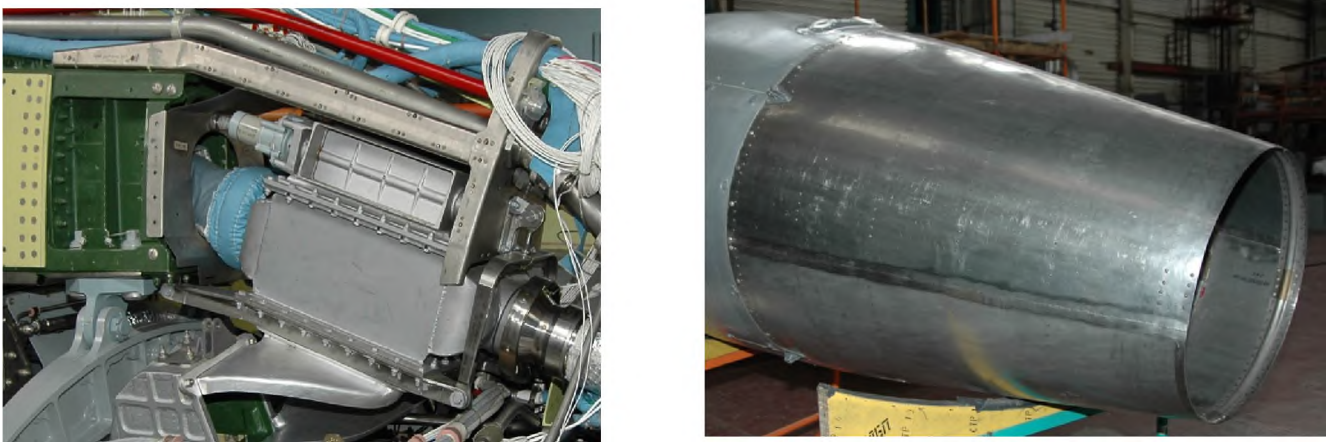

Fig.10. Titanium mount of door of passenger cabin of airplane.

High temperature of melting, low heat conductivity, good technological characteristics - it is those properties, due to that titanium alloys are used in blackout fire-prevention partitions that

localize flame in case of fire, exhaust nozzles and edging of air-frame in the places of exhaust of products of incineration from the engine of Fig.11.



*a* *b*  
Fig.11. Using titanium alloys in fire-prevention places:  
*a* - fire-prevention partition; *b* - an exhaust nozzle

Use of the low alloyed alloys (Grade 2, IT7M, TA16) for pipelines and heat-exchangers of the air system and system conditioning of airplane is based first of all on physical property of titan - the least coefficient of thermal expansion among well-known construction materials. The air system of airplane takes away hot air ( $\sim 770$  K) from an engine and transports it to the consumers - systems of climatization in a flight compartment and salon of airplane and deicer system, providing heating of front edges of wing, plumage and air intakes of engines for the exception of their icing on flight. A working temperature of pipelines is  $\sim 530$ K, that results in thermal tensions in the knots of fastening of pipes (cyclic in exploitation of hot-cold) to the cold air-frame. The size of these tensions is proportional to the coefficient of thermal expansion of material of pipe, difference of temperature of pipe and framework, module of resiliency of material and thickness of wall of pipe. For work in the conditions of cyclic changes of temperature in interval 213 – 580K can be used the stainless steel, nickel or titanium alloys. Nickel alloys in this interval of temperatures with economic and technical points of view not expediently.

Taking into account that coefficient of thermal expansion of titanium ( $\alpha=9.3 \cdot 10^{-6}$  degree<sup>-1</sup> in an interval 293-723 K) in two times less than at austenitic steel of Fe - 18 Cr – 10Ni ( $\alpha = 18.2 \cdot 10^{-6}$  degree<sup>-1</sup> in an interval 293-723 K), and also substantially less elastic module, accordingly  $E_{Ti}=120$  GPa,  $E_{steel}=210$  GPa at approximately equal strength, then fundamental efficiency of titanic alloys is obvious for the indicated construction. If to the indicated advantages to add and considerably less specific gravity of titanium ( $d_{Ti}=4500$ kg/m<sup>3</sup>,  $d_{steel}= 7900$  kg/ m<sup>3</sup>) that we will have and advantages in mass pipes, as geometrical sizes of pipes determined by the parameters of work of the system and does not depend on mechanical properties of material, father-in-law titanic pipes will be on 40% easier than steel. Technological properties of titanic alloys allow making the pipelines of difficult geometrical form (Fig.12) with necessary exactness. In addition the economy of weight of the system will include less of compensator of thermal expansion.

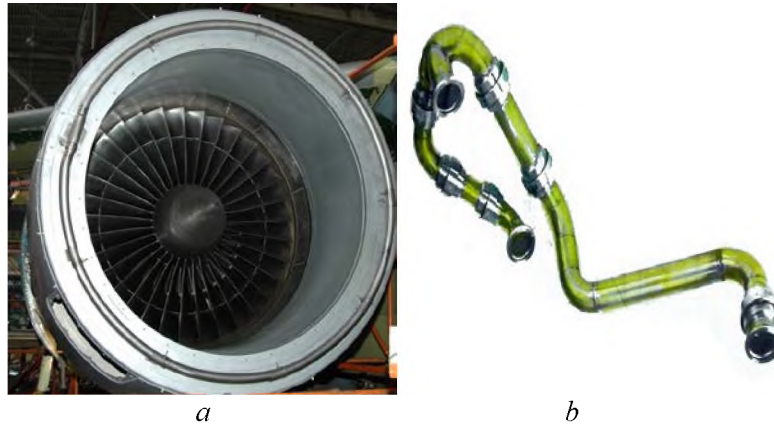

Fig.12. Titanium in the pipelines of difficult geometrical: *a* – micro ejector pipe of heating of intakes of engine; *b* - fragment pipeline of difficult spatial form with the compensator of thermal expansion

### 3. CONCLUSIONS

It is shown, that maximal efficiency from the use of titanic alloys in airplane constructions it is possible to attain taking into account all properties of titan - physical, chemical, mechanical, technological and operating.

#### Speaker



Oleksandr Moliar

*“The Earth is the cradle of humanity,  
but one cannot eternally live in a cradle.”  
Konstantin Tsiolkovsky (1857 to 1935),*

## **REUSABLE SPACE SYSTEMS: FROM THE SPACE SHUTTLE TO THE SAVED FIRST STAGES**

**Anatolii Kretov<sup>1</sup>, Temur Usmonov<sup>1,2</sup>**

1 – Nanjing University of Astronautics and Aeronautics, College of Aerospace Engineering,  
29 Yudao St., Nanjing 210016, P.R.China

e-mail: [kretov-ac@nuaa.edu.cn](mailto:kretov-ac@nuaa.edu.cn)

2 – Department of Aircraft design, 81# Totuvlik St Fergana, 10100, Uzbekistan

e-mail: [temur2691@icloud.com](mailto:temur2691@icloud.com)

**Key words:** Launch Vehicle, reusable system, reusable first stage, specific cost of launch

**Abstract.** This work describes some facts, related to the salvation of the launch vehicle. It also takes into consideration the economic feasibility and natural resources. It emphasizes the importance of influence factor of series production to assess the effectiveness of the use of reusable elements. To this purpose, the model can be used by the competitive environment in which the product competes with its counterpart upgraded with finite capacity on the market.

**Abbreviation:** LV – launch Vehicle; SS – Space Shuttle Systems; LEO – Low Earth Orbit; PL – launching the payload.

### **1. INTRODUCTION**

The critical problem facing the 21st century of space flight is immediate and low cost access to Low Earth Orbit (LEO). An inherent difficulty in escaping Earth's gravitational influence to establish a circular or elliptical orbit about Earth, even at low altitudes, is the genesis of this problem. The vast amount of energy necessary to perform this task requires that space launch vehicles, using the current proven technology developed over the past 100 years, be powered by chemical rocket engines using enormous quantities of propellant. Often times upwards of 90% (or more!) of the gross mass of any orbit-bound rocket is entirely propellant. However, once a stable orbit around the Earth has been attained, the laws of orbital mechanics illustrate that travel to other bodies in our solar system (the Moon, Mars and beyond) use significantly smaller percentages of the total propellant mass used to get to LEO. Or as the famed author Robert Heinlein succinctly described: *once you get to the Earth's orbit, you are halfway to anywhere in the solar system.* Indeed this is not far from the truth.

One of the most important operational indicators of a Launch Vehicle (LV) as a vehicle is the specific cost of Launching the Payload (LP) into the target orbit, which is directly dependent on the cost of manufacturing the launch vehicle. The minimization of the cost of production of the LV can be achieved by rational combination of the used construction materials and technologies, as well as by optimizing the characteristics of components, for

example, reducing the cost of the remote control by refusing to use the liquid-propellant rocket engine with a high pressure in the combustion method, lowering the requirements for the accuracy of a complex of command instruments due to the integration of the control system with navigation equipment for consumers, etc

More than 60 years have passed since the beginning of regular space flights. However, the methods of delivering the target load into outer space remained at the initial level. One of the main indicators of assessing the efficiency of the transport space system is the cost of delivery of a paid load to a given orbit where  $c_{pl}$  is unit cost of delivery of paid load;  $C$  is the total cost of start-up;  $m_{pl}$  is the mass of pay load

$$c_{pl} = C / m_{pl} \quad (1)$$

Accordingly the level of prices for space transport services continues to be quite high, which significantly hinders the development of space activities. One of the ways to solve this problem is the creation of reusable rocket and space systems, which are the stage of evolution of Launch Vehicles (LV). Theoretically, such systems will have operational advantages over single-use LV by reducing the unit cost of removal provided by the reuse of the very expensive blocks and reducing the environmental load on the launch routes due to the reduction or complete absence of areas of fall of the separating parts.

There have been several attempts to create a space transportation system with reusable elements, but they were either not brought to the stage of normal operation, or does not have the desired effect in terms of reducing the unit cost of removal compared to single-use LV. The biggest bright example of such a system was the American system "Space Shuttle" (SSS), operated in the period from 1981 to 2011. When deciding on its development, it was assumed that the system would be fully reusable.

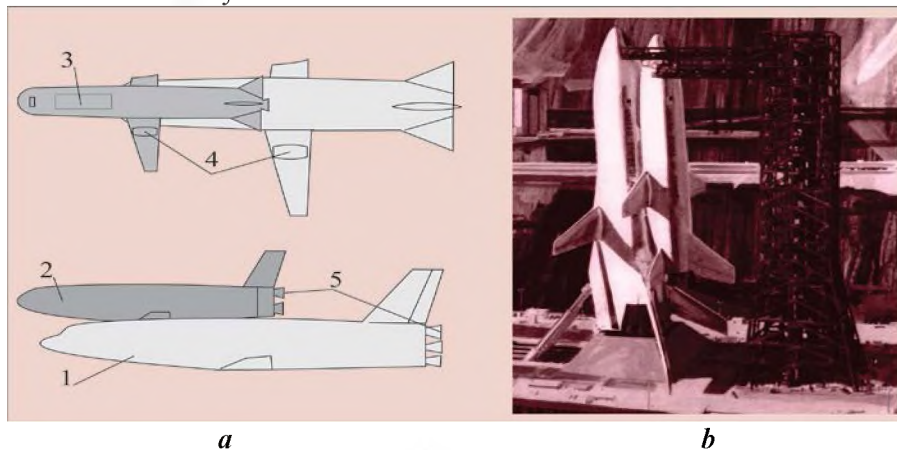

Fig.1. One of the first project fully reusable space system (Draft 50)  
*a* – SS layout: 1 – aircraft-carrier-buster; 2 – Orbiter; 3 - compartment for the crew and passengers; 4 – propulsion turbojet; 5 – rocket liquid engine; *b* – model of the system

But even such a power as the United States could not pull the project completely saved the system. In this connection was created the partly reusable system. Actually, what was eventually implemented should be providing a radical (several times) reduction in the unit cost of removal. To a large extent, the forecast of economic efficiency of the SS was based on the assumption that the cargo flow to the orbit will continuously increase, as a result of which the SS will have to perform up to 50 flights per year, delivering to a low orbit at least 800 tons of pay load and returning to Earth about 400 tons using a reusable winged second stage.

In fact, the cargo flow to the near-earth orbit has stabilized at a level several times lower than expected, and the possibility of SS to return the goods to Earth is practically not used. As a result, Space Shuttle was more than twice as expensive as a single-use LV in terms of the unit cost of its launch. A certain role in this was played by a large number of disposable elements on the rescued first stage: the bow compartment, parachutes, rocket engines of solid fuel separation, supersonic part of the nozzle of the main engine, etc. Over 135 launches of this system has accumulated a lot of experience in the concept of reusability. Two disasters Challenger 1986 and Columbia 2003 and the unprofitability of the system forced to put an end to this major project. A similar system, Energia-Buran, created in the USSR was the only successful launch in 1988.

## 2. MAIN PART

### 2.1. About using of aerodynamic return principal

The Orbiter of SS and aero-space plane Buran (Fig.2) were used for reentry of aerodynamic return principal Fig.3.



Fig.2. Aero-space systems Space Shuttle and Energia-Buran

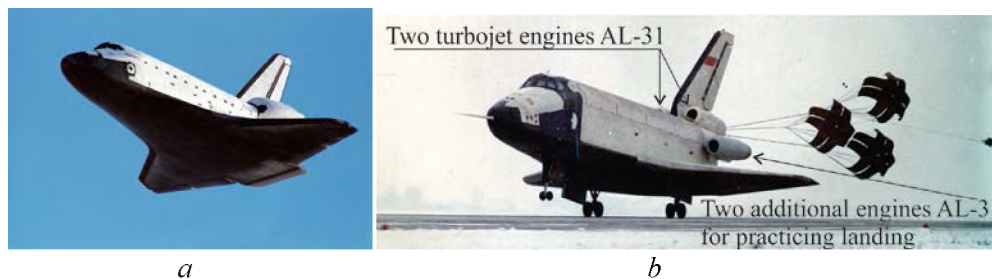

Fig.3. First aero-space planes: *a* – descent of Orbiter Space Shuttle;

*b* – testing of landing of aero-space plane Buran with using of turbojet engines

Aerospace plane SS could land only at the expense of glider flight and Buran was designed on the its landing part of trajectory using two turbojet engines. But in its once and only flight they were not used.

One example of this principle of salvation is the development of a preliminary design of the Russian reusable rocket Baikal (Fig.4).



Fig.4. The layout of the reusable booster "Baikal" presented at the Moscow air show MAKS-2001

This booster could use in different variants – Fig.5. Studies in Russian Federal State Unitary enterprise GKNPTS them. Khrunichev in 2012-2013 on the technical task of the Russian Space Agency for the use of two reusable rocket units of the first stage, equipped with a similar aircraft-type rescue system, ensuring their direct return to the launch area, and a one-time second stage [2]. According to the design results, it was found that the return system almost doubled the weight of the first stage structure, significantly raising its cost, and also required the mandatory use (to compensate for losses in the LV energy) of a technologically complex and expensive cryogenic second stage in operation. As a result, the specific cost of such LVs was estimated to be at least 1.7 times higher than that of disposable system.

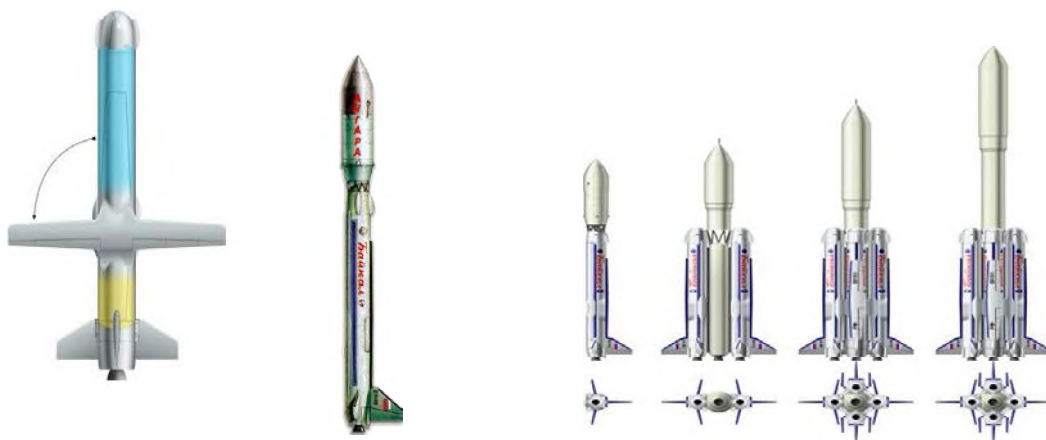

Fig.5. The use of reusable booster "Baikal" with folding wing in different versions

The returned unit will be possible to reapply up to fifty times. After that, the main engines may be replaced with new ones. Due to such savings, the cost of launching reusable Russian missiles will be lower than that of competitors in the class, one and a half or even two times. OAK (Joint Aircraft Corporation) and Roscosmos are working on the project of the return launch complex. The first tests are expected in 2022. The new LV is expected to be Russia's response to Elon Musk's Falcon 9.

In Germany the ASTRA study investigated such autonomous air-breathing powered Liquid Fly-Back Booster as shown in Fig.6 as Ariane 5 modernization option.

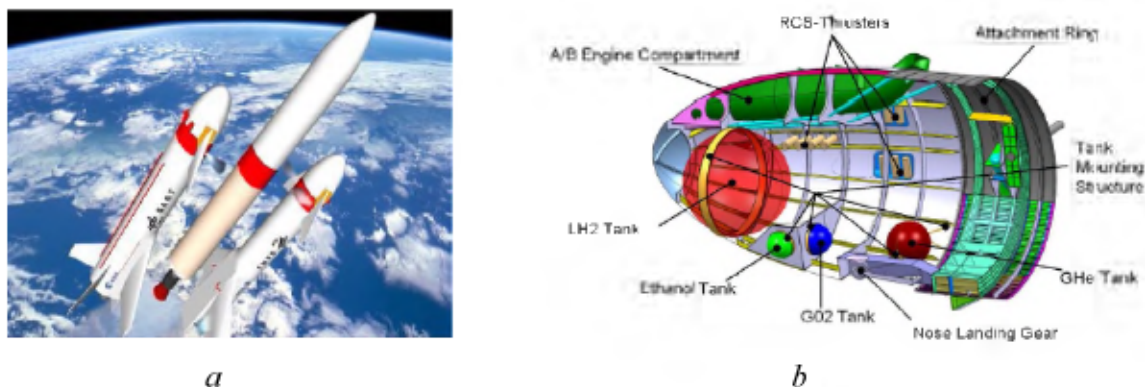

Fig.6. Reusable ASTRA system: *a* – artist view on separation from Ariane LV; *b* – integration of turbofan engine and auxiliary tank in nose of ASTRA booster

## 2.2. About using rocket-dynamic systems of salvation

This method of LV preservation was widely discussed and considered in 1990, when the development of the Delta Clipper single-use rocket was announced. This flight vehicle (FV) was considered in competition with other single-stage FV, using the aerodynamic principle of reentry with a horizontal (aircraft) landing, similar to that of the Shuttle Orbiter – Fig.7.

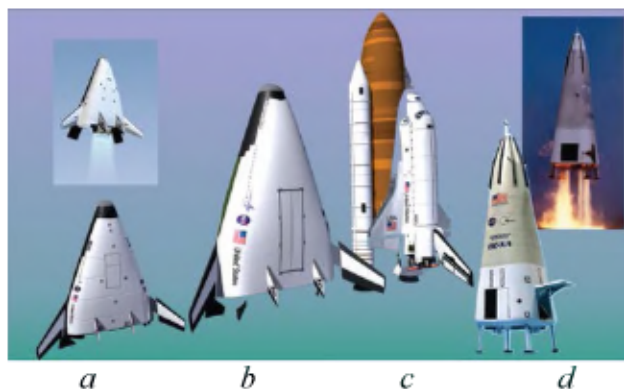

Fig.7. A comparison of the size of different space transport systems: *a*– experimental aircraft X-33; *b* – VentureStar; *c* – Space Shuttle; *d* – Delta Clipper

Currently, the American company SpaceX has made great progress in the creation of partially reusable LV. The concept of the LV Falcon-9 with the first stage being salvaged, developed by its, involves the use of a rocket-dynamic rescue scheme, including controlled re-entry into the atmosphere and vertical landing on the marine platform by re-switching on part of the engines of the propulsion system (Fig.8). In the long term, the possibility of direct landing of the first stage in the launch area by performing a separated stage of the return maneuver in the vertical plane using the thrust of the main control unit, which consumes part of the working fuel supply for these purposes, is considered. This salvation scheme is a continuation of American projects such as the Delta Clipper and K-1, but the developers of SpaceX were the first to bring the LV with a rocket - dynamic stage rescue system to the stage of full flight tests.

It is obvious that the installation of the rocket-dynamic system of the first stage rescue, like any other, will lead to a decrease in the energy capabilities of the LV, including due to the need to form such flight parameters at the time of the stage separation, which will provide acceptable conditions for loading the stage structure at the entrance to the atmosphere. From



this point of view, there is a need to assess the energy costs determined by the losses of the PN, to perform various options for rocket-dynamic maneuver, including direct (without intermediate landing) return of the stage to the launch area, as well as the level of limit loads acting on the stage design at the rescue side [1-2].

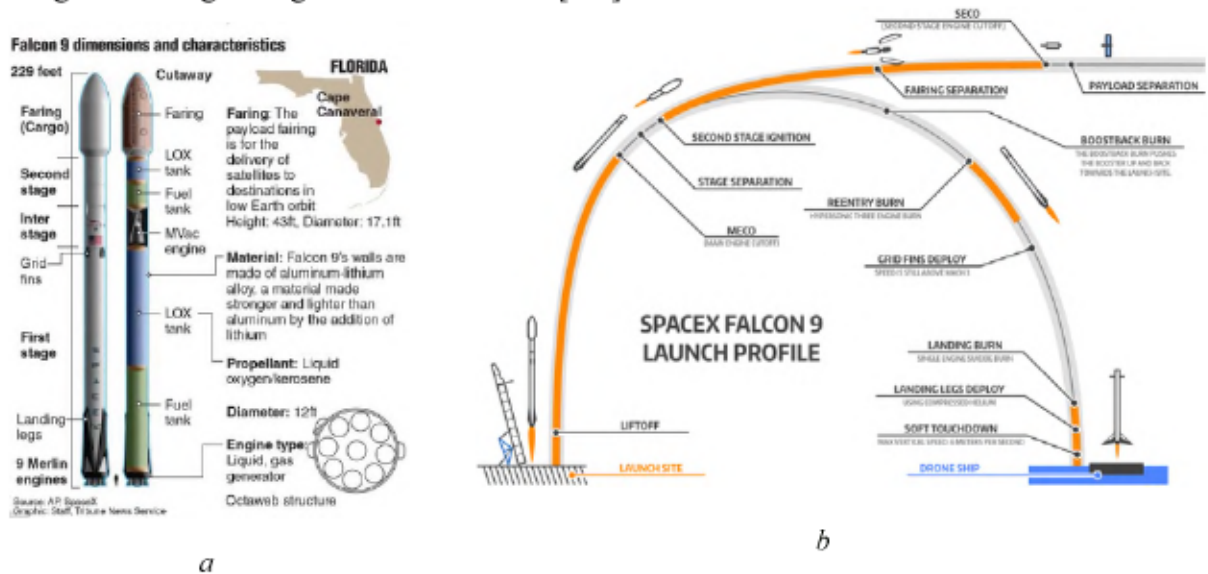

Fig.8. LV Falcon-9: *a* – scheme of the with reusable first stage; *b* – the launch profile and the landing of the first stage on a drone ship in open sea

In this work was made the analysis of various schemes for the use of the first stage from the unsaved version to the rescued with landing on the marine platform without a preliminary braking impulse, with a preliminary (to reduce loads) and the option of returning the spent first stage to the launch site - Fig.9, 10.

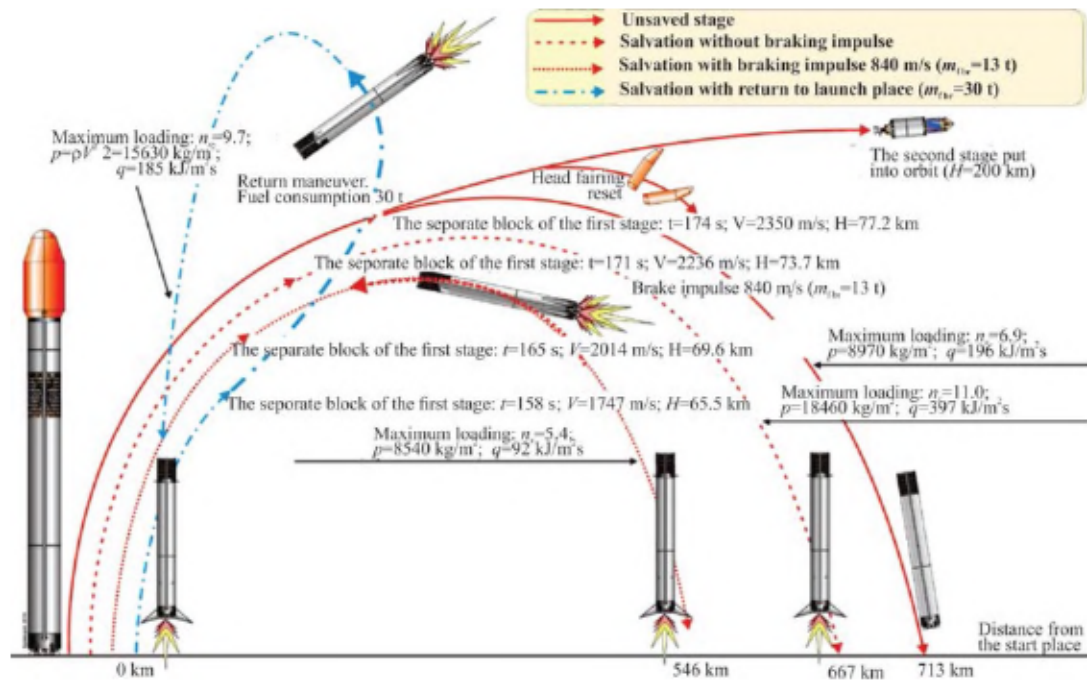

Fig.9. Four patterns of Falcon-9 first stage flight [2]

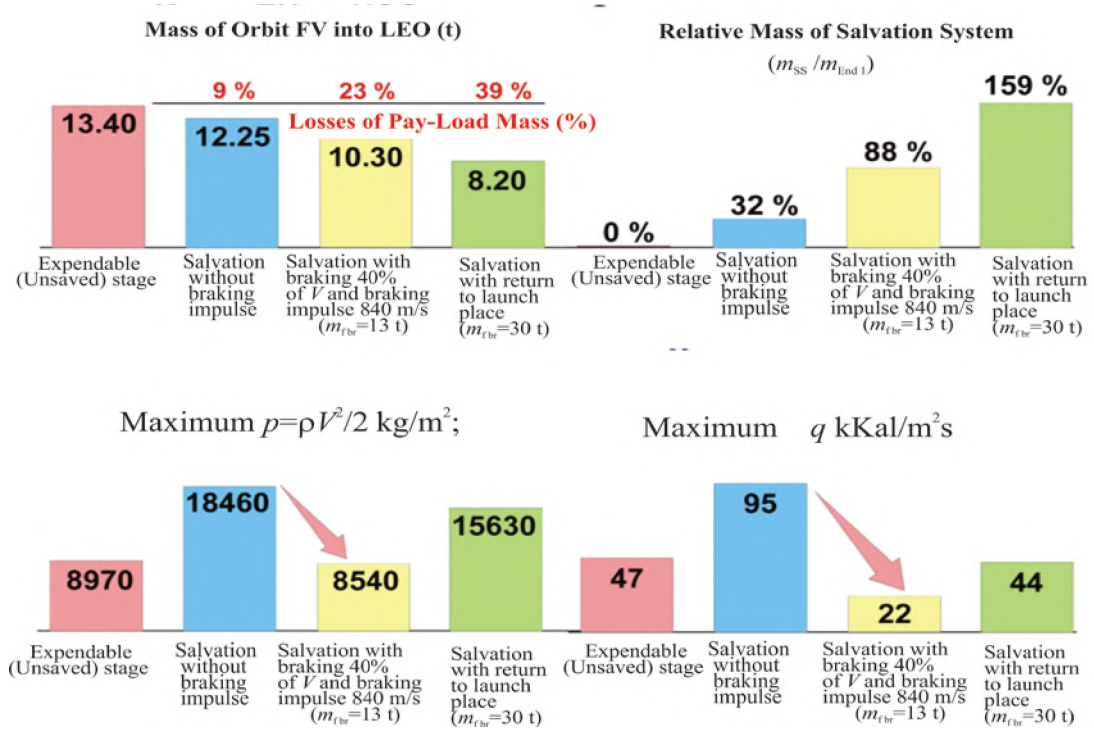

Fig.10. Analysis of the impact of the first stage flight scheme on the energy mass characteristics of the entire system [2]

### 2.3. Method of estimation of change of payload mass

At the very beginning of the analysis of the effectiveness of the use of different variants of rescue schemes at the first stage, we propose to use a simple technique based on the Tsiolkovsky formula. For one-stage LV it is

$$V_{a,t} = V_e \ln (m_0/m_t) = -I \ln (1 - m_f/m_0) \quad (2)$$

where  $V_{a,t}$  is the ideal (absolute) speed of a rocket, acquired during time  $t$ ;  $V_{a,t} = V_t + \Delta V_{L,t}$ ,  $\Delta V_{L,t}$  is various speed losses for the time  $t$ , including aerodynamic, gravitational, etc.;  $I$  is specific impulse  $I=V_e$ ;  $V_e$  is effective exhaust velocity of rocket engine combustion products;  $m_0$  and  $m_t$  are the initial and final mass of the rocket respectively;  $m_f$  is mass of fuel burned during time  $t$ .

From (2) we have

$$\mu_f = m_f/m_0 = 1 - 1/e^{V_{a,t}/V_e} \quad (3)$$

On the example of a multistage space system shown in Fig.11, we assume the following notation scheme of LV blocks and its stages:  $M_{0,i}$ ,  $M_{e,i}$ , are inial and end mass of  $i$  stage;  $m_{0,i}$ ,  $m_{e,i}$ ,  $m_{UI,i}$  are inial and end mass of  $i$  block;  $m_{UI,i}$  is the usefull load for  $i$  stage and obviously that  $m_{UI,i} = M_{0,i+1}$ .

For example of Fig.11 the mass of an orbiter (ASC)  $m_{ASC}$  is the usefull load for  $N$  last stage  $m_{UI,N} = m_{ASC}$ .

The relative fuel mass of the stage  $i$  is

$$\mu_{f,i} = m_{f,i}/M_{0,i} = \mu_{f,i}^* [1 - m_{UI,i}/M_{0,i}] \quad (4)$$

where  $\mu_{f,i}^* = m_{f,i}/m_{0,i}$  is the relative fuel mass of the block  $i$

From (4) we can obtain:

for the  $i$  stage

$$M_{0,i} = m_{UI,i} \mu_{f,i}^* / [\mu_{f,i}^* - 1 + 1/e^{(V_{a,i} + \Delta V_{L,i})/V_e}] \quad (5)$$

for the  $N$  stage

$$M_{0N} = m_{ASC} \mu_{fN}^* / [\mu_{fN}^* - 1 + 1/e^{(\Delta V_N + \Delta V_{LN})/I_N}] \quad (6)$$

For the first stage that will be the start mass of LV

$$M_1 = M_0 = m_{ASC} (\text{Pr}_1^N \{ \mu_{f1}^* / [\mu_{f1}^* - 1 + 1/e^{(\Delta V_1 + \Delta V_{L1})/I_1}] \}) \quad (7)$$

where  $\text{Pr}_1^N$  indicates a multiplication sign from 1 to  $N$ .

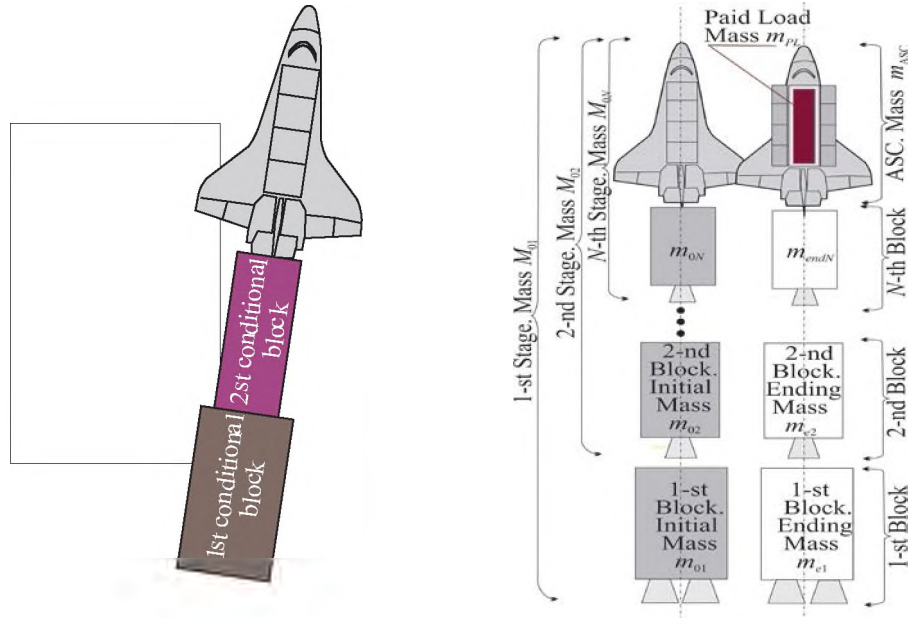

Fig.11. The accepted scheme of designation of LV elements

If we proceed from the given initial mass, we can calculate the mass of the load to be put into orbit

$$m_{ASC} = M_0 / (\text{Pr}_1^N \{ \mu_{f1}^* / [\mu_{f1}^* - 1 + 1/e^{(\Delta V_1 + \Delta V_{L1})/I_1}] \}) \quad (8)$$

Mass of pay load expressed through the orbiter mass obtained from (8) by statistical coefficient

$$m_{pl} = \mu_{pl} m_{ASC} \quad (9)$$

When assessing the effectiveness of the flight scheme, we assume that the starting mass is determined by the engine capabilities of the engines of the first unit and therefore it will remain constant in all researches variants.

As a result, the formula for the estimated of the specific cost of withdrawal of the payload will be as follows

$$c_j = C_j / \{ \mu_{pl} M_0 / (\text{Pr}_1^N \{ \mu_{f1}^* / [\mu_{f1}^* - 1 + 1/e^{(\Delta V_1 + \Delta V_{L1})/I_1}] \}) \} \quad (10)$$

where  $C_j$  is the total launch cost for  $j$  flight scheme.

In the analysis we can use the data of Tabl.1 and 2 ([2-3]).

Table 1. Mass summary the one-time option LV of Falcon-9

Parameter	Block 1	Block 2	ASC
Dry mass (Design), t	23.50	6.12	13.4
Working fuel capacity, t	358.49	90.45	
Fuel residues, t	5.38	1.36	
Etching, t	0.07	0.03	

Table 2. Mass characteristics of salvation system of Falcon-9 first stage

Parameter	Block 1
Landing legs with drives, kg	2500
Aerodynamic rudders with drives, kg	300
Reaction Control System with fuel capacity, kg	100+150
Fuel consumption of the main engine	Is determined by the flight scheme

The calculations performed by the formula (8) are showed a satisfactory agreement with the data from work [2] presented in Fig.10.

### 3. CONCLUSIONS

One of the ways to solve the problem reduces specific cost launches payload into LEO is to create and developing multi-rocket space- systems with reusable elements. Theoretically and practicaly such systems will have operational advantages over disposable LV's due to a reduction in the specific cost of elimination, provided by the repeated use of the material part and a decrease in the environmental load on launch routes due to a decrease or complete absence of areas of falling of the separating parts. For these purposes, a simple method of initial evaluation of the use of different trajectories of descent of the first stage is proposed

### References

- [1] Martin Sippel, Sven Stappert, Leonid Bussler, Etienne Dumont. Systematic assessment of reusable first-stage return options. 68th International Astronautical Congress, Adelaide, Australia. 2015.
- [2] U. L. Kuznetsov, D. S. Ukraintsev. Analysis of the influence of the scheme of flight of the stage with a reactive recovry system on the energy characteristics of a two-stage medium class launch vehicle. Bulletin of samara state aerospace university vol. 15, № 1, 2016. P.73-80. (in Russian)
- [3] <http://spacex.com> – «space x» official website.

### Authors



Anatolii Kretev



Temur Usmonov

## SING PARACHUTE SYSTEM FOR SALVATION OF THE FIRST STAGES OF LAUNCH VEHICLES

V. Chizhukhin<sup>1</sup>, Yu.Mekhonochin<sup>1</sup>, S.Zhjurov<sup>1</sup>, Yu.Gvozdev<sup>2</sup>, V.Yushkov<sup>2</sup>, A.Lykov<sup>2</sup>

<sup>1</sup> Joint Stock Company “Atmosphere”

Pervomayskaya str., 3, Dolgoprudny 141700, Russia, [atmvcps@yandex.ru](mailto:atmvcps@yandex.ru)

<sup>2</sup> – Central Aerological Observatory

Pervomayskaya str., 3, Dolgoprudny 141700, Russia, [v\\_yushkov@mail.ru](mailto:v_yushkov@mail.ru)

**Key words:** Method of Teaching, Aircraft Design, First-Years Students, Nanjing University of Aeronautics and Astronautics

**Abstract.** *The purpose of the project – development of the technology for the salvation of the first steps and propulsion systems which are the most expensive part of the launch vehicle (LV). Life and reliability of control ensure their re-use in the absence of mechanical damage after use. Reuse LV stages can reduce the cost of launching rocket. This project suggests a new well-grounded concept of parachute application using high-temperature, heat-resistant silica and quartz textile materials (new in parachute building) already brought to a commercial level, which has led to the creation of a new class of aerospace parachuting systems. The proposed concept implies that stabilization, deceleration, descending, and landing of a 3.5 -11 ton LV is performed with the same aerospace parachute system and the ASPS is initiated immediately after used rocket unit separation from booster rocket.*

### 1. INTRODUCTION

Despite the short time of its development, cosmic economy has made considerable progress in creating systems important in today's life. The types of manmade extraterrestrial objects already number a few hundreds, while the total number of such objects has reached several thousands. Early experiments in space communication, Earth's monitoring, space navigation, and other fields have paved the way to the deployment of multi-spacecraft systems, which, in turn, has made a revolution in these applications.

All spacecraft are carried into orbit by space cargo ships (SCSs). The energy required to launch space objects is such that the mass of spacecraft to be put into a low orbit is not more than 5.5% of booster rocket launching mass, and less than 1.5% for those carried into a geostationary orbit. This explains why the cost of launching payload is so high - from 3000 to 30,000 US dollars per kilogram.

Today, the SCS fleet mainly employs single-mission booster rockets (BRs). The criteria that determine the practicability of creating new SCSs are their economic efficiency and, recently observed, ecological safety. One of the appropriate engineering solutions, which is discussed in detail in this report, implies the recovery of the BR or its most valuable component – propulsion bay section (PBS) with fluid jet engine (FJE) - using a parachute system (PS), and their multiuse. Depending on FJE purpose and lifetime, its cost may reach 90% of BR cost. A BR can be recovered from its landing place by helicopter or other means. Then, its separate units and valves can be dismantled, checked for operability, and used in another BR.

Many schemes for engine recovery have been considered in the past. Parachute recovery of an engine module to the ocean suffers from high-impact loading and exposure to harsh ocean environments which require a complex system to fully seal off the engine. United Launch Alliance (USA) is investigating recovery of rocket engine modules. Using helicopter mid-air recovery as the engine module descends under a parafoil is a low-development-cost approach which brings back the booster engine with exposure to only benign environments.

The task of development ASPS working at heights from 60 to 150 km at hypersonic speeds requires a combination of theoretical and experimental work in the field of high temperature and dynamic loading of all elements ASPS and especially in the field of theoretical models of filling large areas of the canopy and the flow in the working (full of) state at high altitudes. Positive experience with parachute systems to save the payloads of Russian meteorological package (entering in the force of the parachute system at the height of 90 km), the modern high temperature textile materials for the parachute, gas-dynamic calculation methods for flow parachute at mesosphere conditions were the basis of the Project.

## 2. MAIN PART

### 2.1. EXPERIENCE OF PARACHUTE APPLICATION FOR METEOROLOGICAL ROCKET SOUNDING

More than 10000 Russian 2-stages meteorological rocket M-100B flights (Fig. 1) were conducted in the Central Aerological Observatory for atmosphere sounding at altitudes of 30-100 km. Each payload was equipped with a parachute system of nylon materials. The surface of canopy was up to 60m<sup>2</sup>. The primary purpose of a parachute - the stabilization and deceleration the payload with scientific instrument weighting 80 kg.. The work phase of M-100B parachute system is shown in Fig.2



Fig.1. Russian meteorological rocket M-100B in flight

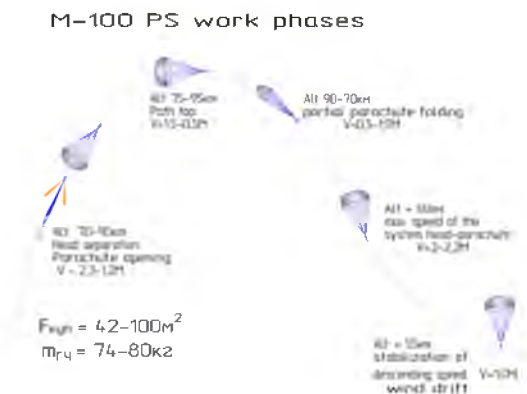

Fig. 2. Work phases of parachute system M-100

Work phase of parachute system is shown in Fig.2. The introduction of the parachute system into action at the height of 60 km at a speed of 1-2 M on the ascent lag of flight has demonstrated the reliability of this procedure.

Due to the dynamic pressure the filling and opening of the parachute canopy occurs at 60-70 km on the ascent. Multiple recoveries of the landed payloads (Fig.3) showed a complete absence of thermal or mechanical damage. Parachutes after landing does not have any trace of the mechanical and thermal effects.

Parachute system input scheme with a proven reliable performance in thousands of meteorological rocket flights can be accepted as the basis for designing the separation container parachute and entry into force ASPS

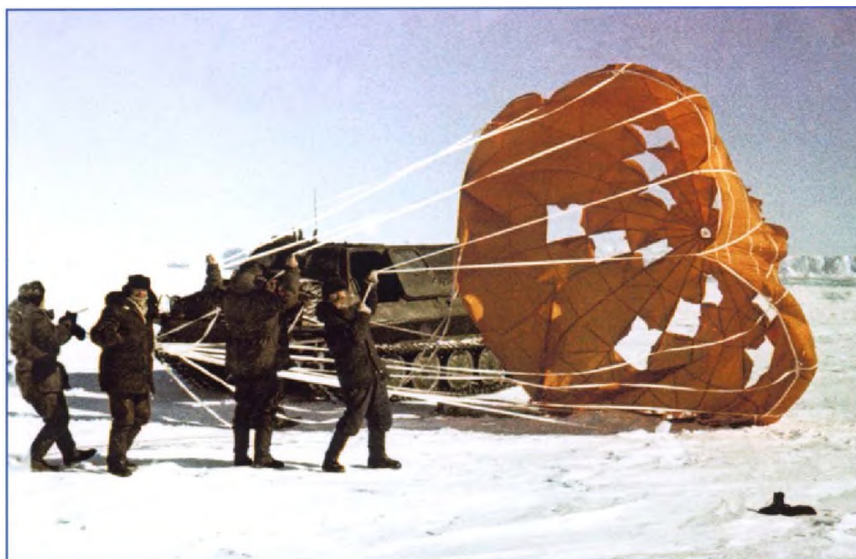

Fig. 3. Parachute recovery after payload landing from a height 90 km

## 2.2. CONCEPT OF ASPS

Application of parachute system for meteorological rocket (PSMR) also shows that similar in topology canopy made of heat-resistant textile materials in principle can be operated in altitude range 60-100 km.

Of course, the specific weight load on the canopy ASPS ( $p = 3 - 9 \text{ kg/m}^2$ ) slightly higher than that of PSMR ( $p = 0.5 - 2 \text{ kg/m}^2$ ) but it only gives the stability of the system during braking and lowering the propulsion system.

Due to the different operating conditions, the structural arrangement, technology of tailoring and parachute deployment the surface of basic canopy for ASPS of  $500 \text{ m}^2$  was selected. It allows to confidently predict its behavior on the base of PSMR experience at least up to a speed of 2.5 M. At the same topology of these systems of geometric similarity ratio is only 1: 2.24. ASPS input scheme is shown in Fig.4.

ASPS starts at altitudes above 60 km at hypersonic speeds  $\approx 3 \text{ km/s}$  at a trajectory angle  $\theta \approx 17-30 \text{ grad}$  (Fig.4). Operational one and same parachutes which carry the stabilization and deceleration both rise to the top of the path, and the descent. The decrease rate of up to  $M < 1$ , and the transition to the vertical motion is carried to an altitude of about 45 km. The landing rocket boosters occurs at a rate of 7 to 15 m/s or a helicopter pick-up is in the air.

The most important aspect of the ASPS development was that of the thermal regime of the parachute.

## 2.3. ESTIMATIONS OF THE THERMAL REGIME OF THE CANOPY

A numerical model of the motion rocket booster with a parachute was developed. The data flight the payload of the meteorological rocket with parachute was used for test calculations.

Drag coefficient for parachute system and the structure of the flow near the canopy were determined.

For estimation the thermal regime the most heat-stressed region of the trajectory (immediately after opening the parachute) was considered with following parameters:

altitude  $H=4360$  m,  $M_o=5.62$ .

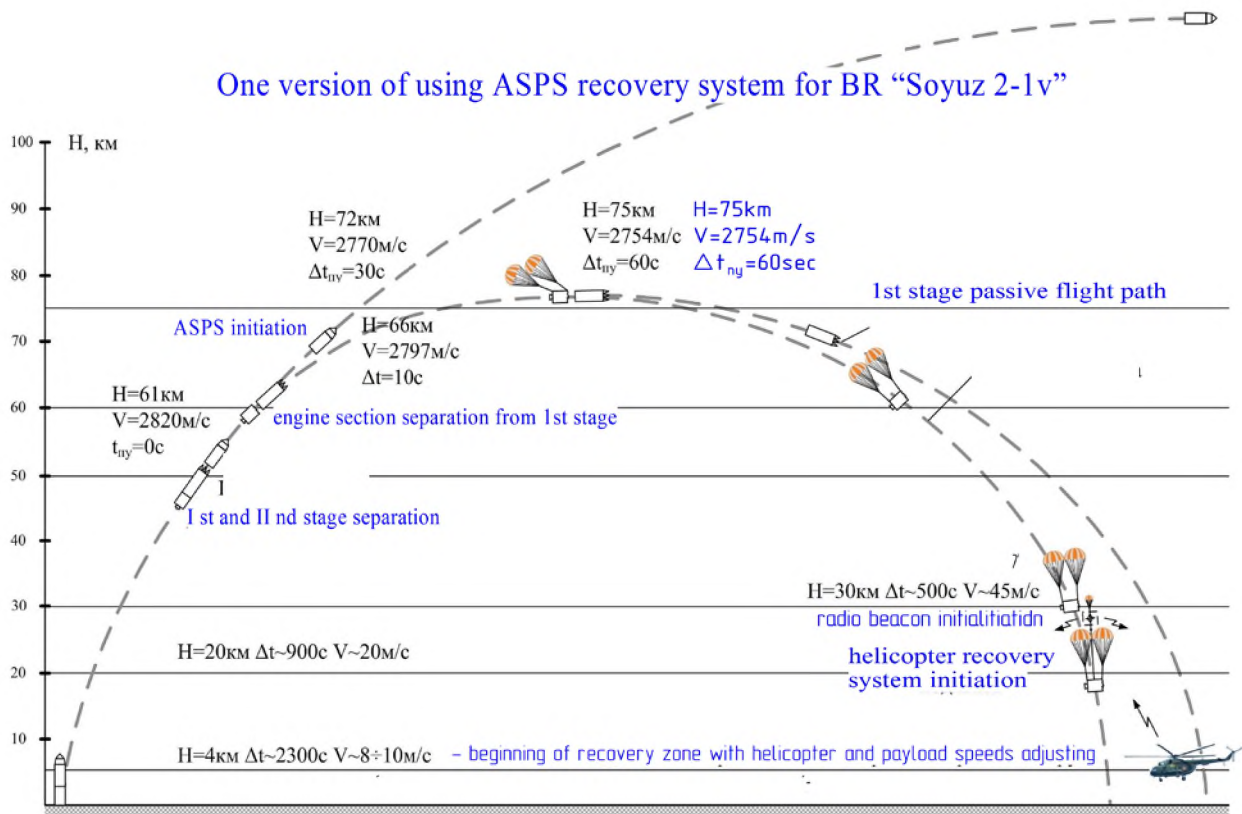

Fig.4. ASPS input scheme

Continual flow regime was determined as a continual and laminar. The canopy is considered to be rigid and impenetrable.

The results of heat flux calculation is given in Fig 5. On the inner and outer surface of the canopy shows contours distribution of heat flux to the cold surface temperature  $T_w = 300$  K.

Each contour specified number of heat flux ( $kW/m^2$ ) to which it corresponds. The pole part of the inner surface of the canopy is the least heat-stressed, heat flow is less than  $2 kW/m^2$ .

Heat transfer increases significantly when approaching the edges of the triangular holes (structural permeability) and reaches values of more than  $7 kW/m^2$ .

In most of the inner surface of the canopy heat fluxes ranging from 1 to  $10 kW/m^2$ . Estimation of the maximum heat flux at the free-edge streamlined canopy corresponds to  $250 kW/m^2$ . On the outer surface of the canopy substantial heat flux values are observed only near the edges of the canopy, the rest of the surface heat transfer is negligible.

Fig. 6 shows the result of the calculation of radiative equilibrium temperature. For the model calculations the emissivity of the surface of the canopy was taken  $\epsilon = 0,85$ . Radiated emissions modeled with only one side of the fabric. Estimate of the maximum radiation equilibrium temperature at the free-edge streamlined canopy corresponds to  $940^\circ C$ .



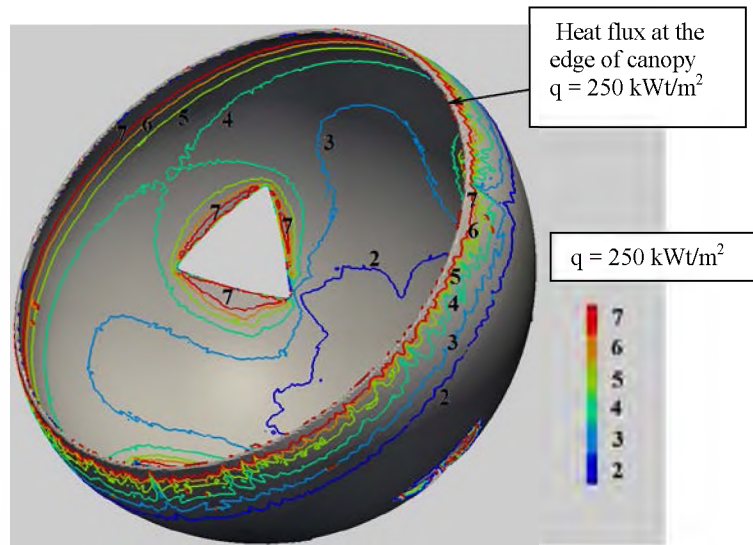

Fig.5. The distribution of heat flux on the surface of the canopy

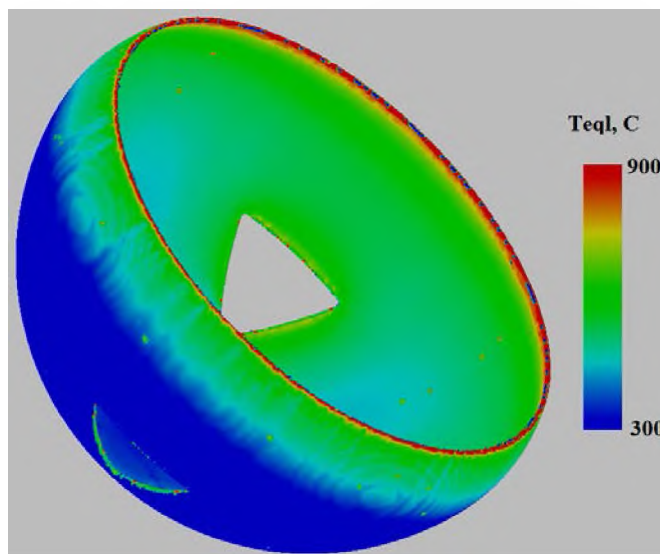

Fig.6. The result of radiative equilibrium temperature calculations for the canopy

#### 2.4. STUDY AND SELECTION THE HIGH TEMPERATURE, HEAT-RESISTANCE TISSUE FOR PARACHUTE.

It is known that silica materials are excellent high temperature insulation and can continuously be used without changes in the properties at a temperature above  $1000^\circ\text{C}$  and briefly at higher temperatures.

It should be noted that for fiber glass fabrics and carbon fabric in technical references practically is no data on the tensile strength at temperatures above  $300^\circ\text{C}$ . Therefore, studies were conducted on the tensile strength of images silica and quartz fibers in the temperature range from  $20$  to  $1300^\circ\text{C}$ .

The laboratory bench Instron 5965 with radiative heating was used (Fig. 7), equipped with a symmetrically located alundum tube with an inner diameter of 5 mm. The test sample was placed on the axis of alundum tube for a few minutes subjected to heating to the predetermined temperature. Some results of the evaluation studies of tensile strength textile threads obtained on the bench Instron 5965 are presented in Fig.8.

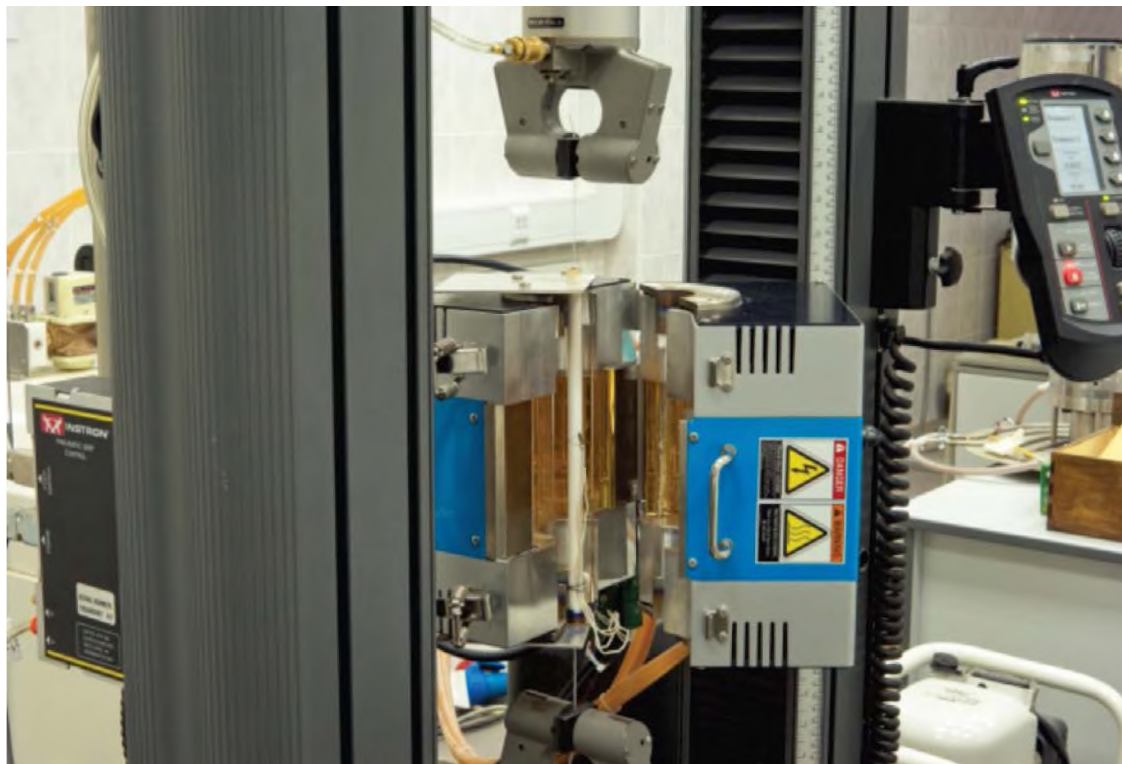

Fig.7. Instron 5965 with radiative heating

It was shown that the tensile strength of the threads of silica and quartz fibers at 1200° C comply with requirements imposed on them by the modes of loading ASPS when braking engine bay of the first stage of the "Soyuz-2" weighing 4.4 tones when entering at a speed of up to 3 km/s, 80 km altitude and trajectory angle 24° on the basis of calculating the parameters of motion of RB-ASPS and calculate the temperature at the point stagnation.

The results of laboratory research of heat-resistant silica and quartz textile materials under high temperature confirmed principle possible to create ASPS for saving the first stage or rocket engine with hardware

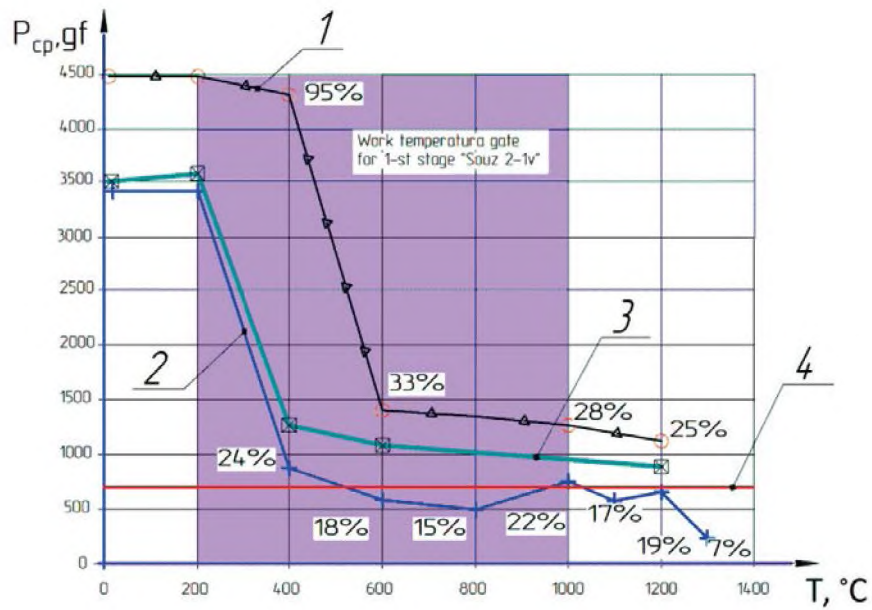

Fig. 8. The results of test on thread of textile and the design criteria of strength to the threads of textile for ASPS to “Soyuz-201b”. Table of symbols:  $P_{cp}$  is tensile strength in gf; Line 1 – for quartz thread; Lines 2,3 – for silica threads; Line 4 – design criteria

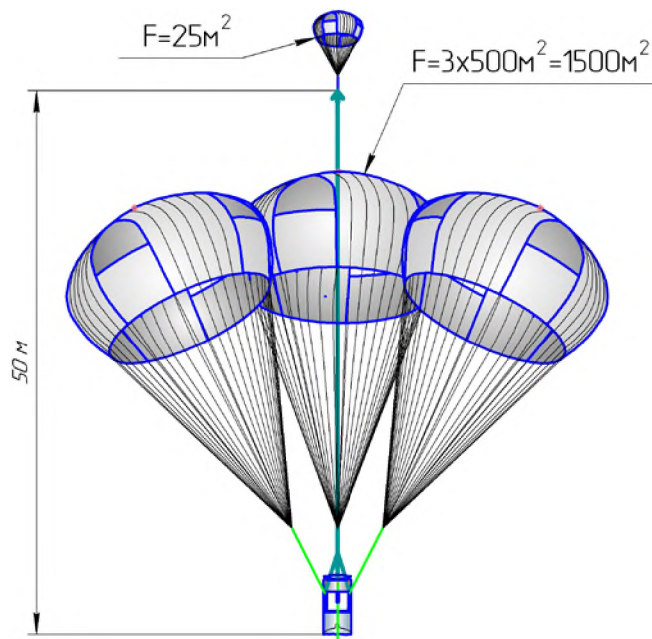

Fig.9. Thirdly canopy parachute system for saving booster rocket weighting 4350 kg providing landing speed of 7.7 m/sec

### 3. CONCLUSIONS

It was proposed and developed a new well-grounded concept of parachute system application using high-temperature, heat-resistant silica and quartz textile materials (new in parachute building) already brought to a commercial level, which has led to the creation of a new class of aerospace parachuting systems - ASPS

This concept implies that stabilization, deceleration, descending, and landing of a 3.5 -11 ton buster rocket (BR) is performed with the same high-temperature textile parachutes, the ASPS initiated immediately after used rocket unit separation from BR.

The results of laboratory research of heat-resistant silica and quartz textile materials under high temperature confirmed principle possible to create ASPS for saving the first stage or rocket engine with hardware

At the altitude 40-45 km ASPS provides the descent velocity values less than Mach number 1 and about 30 minutes prior to landing that is comfortable for helicopter recovery

The next major steps to enable actual ASPS include: refinement and test high-temperature, heat resistant textile for application in parachute systems (1), ground and bench working off ASPS units (2), flight test the prototypes of ASPS on board of meteorological rockets (3).

## INITIAL AIRCRAFT SIZING – A CRITIQUE

**Anthony P. Hays**

California State University Long Beach  
1250 Bellflower Blvd, Long Beach 90840, USA

Email: [ahays@alum.mit.edu](mailto:ahays@alum.mit.edu) Web: [www.adac.aero](http://www.adac.aero)

**Key words:** Aircraft design, aircraft sizing

**Abstract:** *One of the first technical exercises for students enrolled in an undergraduate aircraft design course is to estimate the required takeoff gross weight of a notional aircraft to meet a given mission requirement. Textbook authors take different approaches to the procedure, and some of these approaches both hide the lack of reliability of input data and in addition may make it more difficult to understand the procedure, and in particular, the high sensitivity of the result to the input variables. Many students will eventually work in technical disciplines that support the design process, such as aerodynamics, propulsion, and structures and materials. They should be aware of the impact of improvements in technologies on the takeoff gross weight (and resultant cost) of the design they are working on.*

### 1. INTRODUCTION

Initial aircraft sizing is the determination of takeoff gross weight (TOGW) to perform the design mission. It is usually the first technical exercise in the design process. In the real world of both commercial and military design development, many design exercises will have been performed in developing requirements, but for college-level design classes, the requirements are usually defined by an independent organization, such as the American Institute of Aeronautics and Astronautics (AIAA). In Raymer [1], initial sizing is described in Chapters 2 and 6. In Nicolai & Carichner [2], it is described in Chapter 5. In other textbooks the process is also described in the early chapters. It is critically important that students fully understand this process, and the sensitivity of input variables (lift/drag ( $L/D$ ), specific fuel consumption (sfc), and empty weight fraction ( $W_e/W_o$ )) to the output value of takeoff gross weight. This sensitivity is a function of the type of aircraft being designed. If students have an image of the empty weight matching process firmly engraved in their minds, they will be much more likely to pay attention to the quality of their subsequent analytical work.

## 2. BACKGROUND

Initial aircraft sizing is usually based on “empty weight matching”, i.e., calculating TOGW by equating the empty weight required ( $W_{eR}$ ) based on a statistical analysis of empty weights of existing comparable aircraft, with the empty weight available ( $W_{eA}$ ) by flying the mission in a computer model (typically a spreadsheet) and subtracting fuel, crew, and payload weight from TOGW (commonly abbreviated as  $W_0$ ).

For the most part, textbook authors are in general agreement about calculating  $W_{eA}$ , using the inverse of the Breguet range equation, except that Schaufele [3] adds fuel fractions, rather than factors them, and this only works for very simple missions, so this procedure is not recommended.

More significant differences are in matching  $W_{eR}$  to  $W_{eA}$ . Textbook procedures may be grouped into three approaches:

- 1) Assuming a linear relationship between empty weight required and TOGW, in which case iteration is not required
- 2) Assuming a non-linear relationship between empty weight required and TOGW, and equating empty weight fraction available ( $W_{eA}/W_0$ ) with empty weight fraction required ( $W_{eR}/W_0$ ), solving iteratively
- 3) Assuming a non-linear relationship between empty weight required and TOGW, and equating empty weight available ( $W_{eA}$ ) with empty weight required ( $W_{eR}$ ), also solving iteratively.

The differences between methods 2) and 3) may appear to be trivial, but they can have a significant impact on the ability of students to appreciate the significance of using the correct inputs.

All the methods for calculating  $W_{eR}$  have an obvious difficulty. If students propose a novel concept (and that should be encouraged), then there are no existing comparable aircraft from which they can estimate the empty weight required for a given TOGW. Even for fairly well established concepts such a blended wing-body, or a box wing, a limited number of weights are available from analytical studies, but there are no weights available for operational aircraft. For a novel concept, students will have to make the best guess.

### 2.1. Linear Relationship Between Empty Weight Required and TOGW

Several aircraft design textbooks show the empty weight fraction ( $W_{eR}/W_0$ ) as a power function of  $W_0$ . If weights data are available for similar designs in the same weight class, this relationship can be expressed more simply as a linear relationship without a significant loss of accuracy. In this most simple form, there are some parts of  $W_{eR}$  that are proportional to  $W_0$  and some that aren't, or

$$W_{eR} = GW_0 + K \quad (1)$$

where  $K$  represents weight that is not proportional to  $W_0$  (such as the cockpit or flight deck and avionics), and  $GW_0$  represents everything else. We can compare these two methods using a spreadsheet. Take the equation in Raymer Table 3.1 and convert it to the form

$$W_{eR} = AW_0^{(C+1)}K_{vs} \quad (2)$$

where the constants are defined in the textbook. Plotting these in a spreadsheet produces a pair of curves looking something like Fig.1 for jet transports.

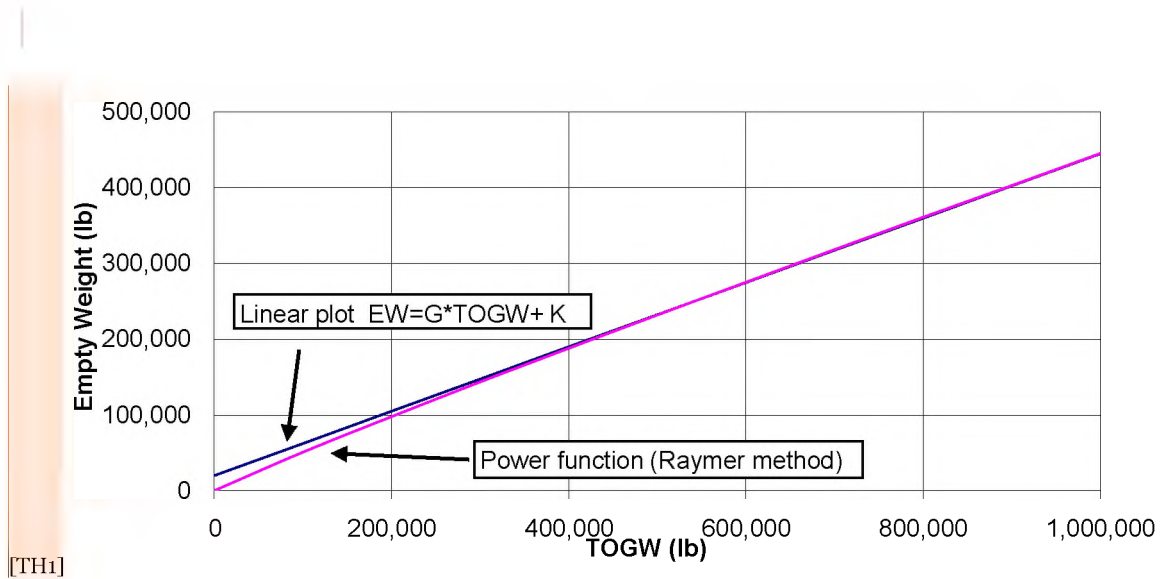

Fig. 1. Comparison of Linear and Power Function Weight Equations for a Jet Transport

For the straight line plot,  $K = 20,000$  lb. and  $G = 0.425$ . This seems reasonable that for aircraft above about 200,000 lb. the flight deck and avionics weigh about 20,000 lbs and everything else is proportional to  $W_0$ .

A benefit of using a linear equation is that the iterative procedure described in Raymer Section 3.6.4 is not required. However, in industrial-grade sizing programs the relationship between empty weight and takeoff gross weight is not linear, and iterative procedures must be used, so it is important for students to learn how to use them.

There are some important differences in takeoff gross weight definitions between military and commercial aircraft. For military aircraft takeoff gross weight may be defined as

$$W_0 = W_c + W_p + W_f + W_{e,A} \quad (3)$$

where  $W_c$  is the crew weight,  $W_p$  the payload weight,  $W_f$  the fuel weight (including reserves) and  $W_{e,A}$  the empty weight available. The payload (or fixed weight), using the Raymer definition, is defined as a combination of non-expendables (such as sensors and guns) and expendables (such as bombs, missiles, ammunition, troops and their equipment, and cargo).

For commercial aircraft the payload is defined as passengers, passenger bags (both checked and unchecked), and cargo (excluding cargo containers).

The takeoff gross weight is then defined as

$$W_0 = W_p + W_f + W_{oe} \quad (4)$$

where  $W_{oe}$  is the operating empty weight (OEW), which is

$$W_{oe} = W_e + W_{op} \quad (5)$$

where  $W_e$  is the empty weight, usually defined as the manufacturer's empty weight (MEW), and  $W_{op}$  is the weight of the operational items. Crew (pilots and flight attendants) weight is absorbed into the operating weight empty, but so have a significant number of other items, such as food and galley service equipment including carts, drinking water, plus cargo containers, cargo pallets, evacuation slides and life rafts, and numerous other items that add up to about 5-6% of OEW.

In Schaufele's [3] weight trend data for commercial aircraft (Fig.3.22 to 3.26), the weights shown are for operating empty weight ( $W_{oe}$ ). When online data is retrieved,

students must check carefully as to whether commercial aircraft empty weights are manufacturer's empty weight or operating empty weight.

To determine values of  $G$  and  $K$  in Eq. (1), students should plot values of  $W_{eR}$  and  $W_0$  for existing aircraft in a given class of aircraft using data that can be found online, using weight values for aircraft designs that are similar to the students' proposed design. For example, for commercial aircraft, if the students' configuration has engines mounted on the rear fuselage, the comparable existing aircraft should have engines similarly located. This should be done whichever method of sizing is used. Useful sources of data are:

- <https://www.wikipedia.org/>
- <http://www.airliners.net/aircraft-data>. When the empty weight is OEW, it is so stated.
- <http://www.aerospaceweb.org/aircraft/>

From Eq. (3), empty weight available may be written as

$$W_{eA} = -(W_p + W_c) + \left(1 - \frac{W_f}{W_0}\right) W_0 \quad (6)$$

where the fuel fraction ( $W_f/W_0$ ) is nominally independent of TOGW and is found by flying a notional aircraft on the design mission to determine mission fuel plus reserves. Taking Eq. (1) and (6) and solving for TOGW for the condition  $W_{eR} = W_{eA}$  produces

$$W_0 = \frac{K + W_p + W_c}{\left(1 - \frac{W_f}{W_0}\right) - G} \quad (7)$$

So why is this procedure not used more often? Possible reasons are:

- 1) over a large range of values of TOGW, the power function relationship is somewhat more accurate,
- 2) most design textbooks use power function relationships, so coefficients are more readily available, and
- 3) in an industrial-grade sizing program, weights are based on physical properties of the components, and the fuel fraction is not quite constant, because the airplane geometry changes slightly as its gross weight changes, in which case iteration is required.

Another way to estimate the values of  $G$  and  $K$  for a single existing aircraft (and by extension for similar designs in the same class) is by examining a detailed weight breakdown, and allocating empty weights as either proportional to TOGW, or independent of TOGW. If there is only one vehicle in the class (such as for the Lockheed SR-71) this may be the only way to go. However, the values of  $G$  and  $K$  are unlikely to be exactly the same in both methods. In the first method, the payload typically increases as TOGW increases, but in the second method it does not, so they can be renamed as  $G'$  and  $K'$ .

From Eq. (7) it is also possible to derive the weight growth factor<sup>[TH2]</sup>, defined as  $\Delta W_0/W_x$ , where  $W_x$  is an arbitrary increase in empty weight, and  $\Delta W_0$  is the resultant change in TOGW. The weight growth factor is

$$\frac{\Delta W_0}{W_x} = \frac{1}{\left(1 - \frac{W_f}{W_0}\right) - G'} \quad (8)$$

where  $W_f$  is the total weight of fuel available. The growth factor can vary from about two for a short-range transport aircraft or light aircraft, to about nine for a high-speed reconnaissance aircraft. This provides students with a qualitative estimate of the effect of advanced technology on TOGW. This exercise is somewhat of an approximation; in



reality the growth in  $W_0$  is also a function of the type and location of the arbitrary weight added. Quantitative effects are discussed in Section 3.

## 2.2. Equating Empty Weight Fractions.

Raymer [1, Fig.3.1] shows empty weight fractions ( $W_{eR}/W_0$ ) as power functions of  $W_0$  for sixteen classes of aircraft (shown as straight lines in Raymer's figure, although in reality the lines are not quite straight). Figure 2 shows curves for nine of these classes in a similar format to that of Raymer. Unfortunately the data points from which the curves are based are not shown in the book, so it is not possible to establish the level of confidence in the coefficients. Raymer's Table 3.1 provides values of  $A$  and  $C$  for the relationship  $W_{eR}/W_0 = AW_0^C$ , with an additional correction for variable sweep wings. This is followed by an example of a manual iteration to solve for a value of  $W_0$  that satisfies

$$W_{eR}/W_0 = W_{eA}/W_0.$$

A plot of  $W_{eA}/W_0$  is not shown. Manual iteration is continued to within 0.05% TOGW of the converged solution, which is much closer than is warranted by the estimated values of  $L/D$ , sfc, and  $W_{eR}/W_0$ . Although this procedure is valid, students will probably fail to recognize the sensitivity of the result to the input variables, and may have more confidence in the result than it deserves.

Why are the gradients of the lines in Fig.2 different for different classes of aircraft? A plausible explanation is that a single-engine general aviation aircraft has typically four seats, so the cabin size does not change much. Similarly, a high-altitude UAV typically has a relatively small and fixed weight reconnaissance payload. Jet transports, military cargo and bombers, and agricultural aircraft, can have an order of magnitude difference in payload between the smallest and largest airplanes in each class, and a change in cabin or cargo hold to accommodate the payload. For these latter classes, the cabin, or payload bay must grow in size and weight, so the empty weight fraction does not decrease so rapidly. This suggests that technology sensitivity studies using this method, mentioned later in this paper, may overestimate the change in TOGW for these classes of aircraft.

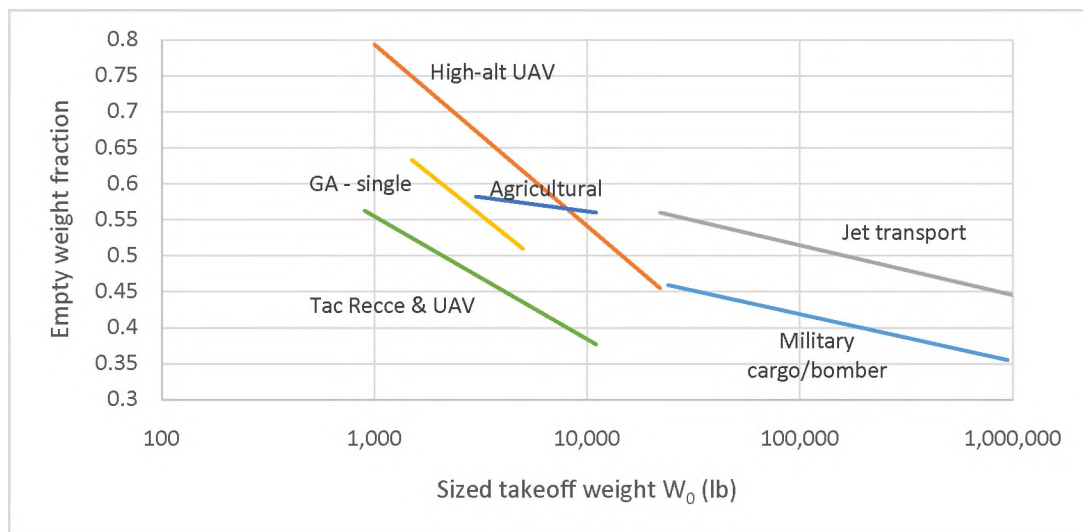

Fig.2. Empty Weight Fraction Trends

### 2.3. Equating Empty Weight Values.

Nicolai & Carichner [2, Fig.5.4] also show data plotted as empty weight ratios, except that a single equation is used for all classes of aircraft, and the vertical axis is logarithmic, which has the effect of compressing data points. The figure shows data points for three classes of aircraft (bomber and transport, light civil aircraft, and fighters). More importantly, in the example calculation of  $W_0$ , [2, Fig.5.5] shows lines of  $W_{eA}$  and  $W_{eR}$  (not non-dimensionalized) as a function of  $W_0$ , and their intersection at an acute angle. A similar figure is shown in [3], Fig. 3-27. It is this form of data presentation that must be engraved in the minds of students, because it shows that small differences in either calculation of  $W_e$  will make a large difference in the value of  $W_0$ . Usually non-dimensionalizing a design variable simplifies analysis and helps students understand the impact of that variable, but this happens to be an exception. (Another exception is the definition of induced drag coefficient, which leads students to believe, erroneously, that induced drag is inversely proportional to aspect ratio, as pointed out by MacLean [5, Sec. 8.3.5]).

Other textbook authors show  $W_{eR}$  versus  $W_0$  for different classes of aircraft, with data points. In particular Roskam [4] shows data for thirteen classes of aircraft, but there have been no updates to the data since 1985. Schaufele [3] shows data for eight classes of aircraft up to the publication date in 2000.

A positive attribute of showing data in the form of Fig. 2 is that it highlights differences between classes of aircraft. If data for aircraft empty weights are shown with logarithmic axes (which is the case in most textbooks) as shown in Fig. 3, then data becomes compressed. Presenting data with linear axes also presents a problem in that most data points are close to the origin, so there no ideal form of presentation. Nevertheless, illustrating the important principles of empty weight matching can best be done with linear axes, as the next section describes.

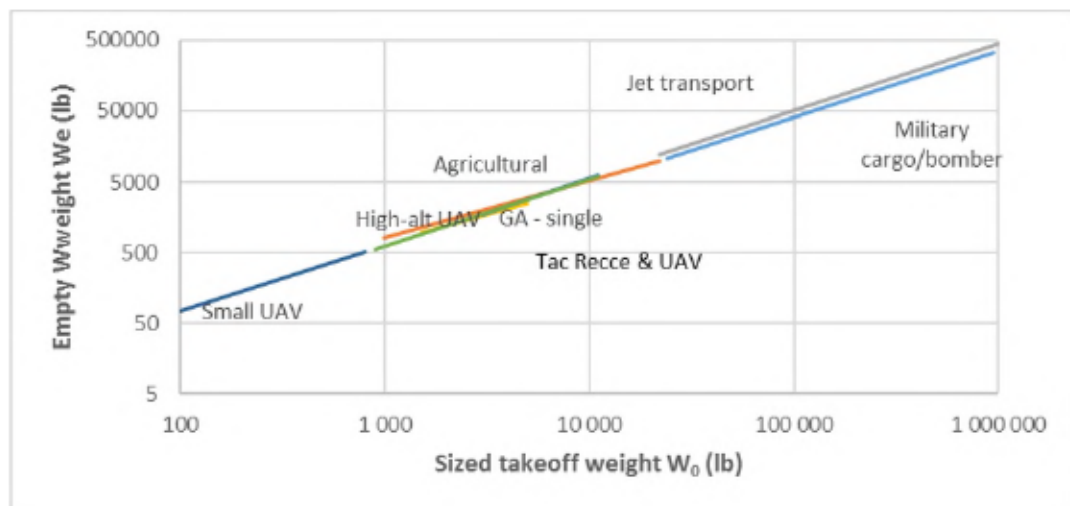

Fig. 3. Empty Weight vs. Takeoff Gross Weight

Students may be lulled into believing that in Fig. 2, the value of  $W_{eR}/W_0$  for an aircraft in a given class of aircraft lies on or close to its curve, so that if other input parameters are close to being correct, the value of TOGW will be close to that of more detailed analysis. If data from Schaufele [3] are plotted, they show that there is wide dispersion of the

points, and for two of the selected classes, the gradients of the trend lines are of a different sign from those of Raymer. Students must recognize that this method is very approximate.

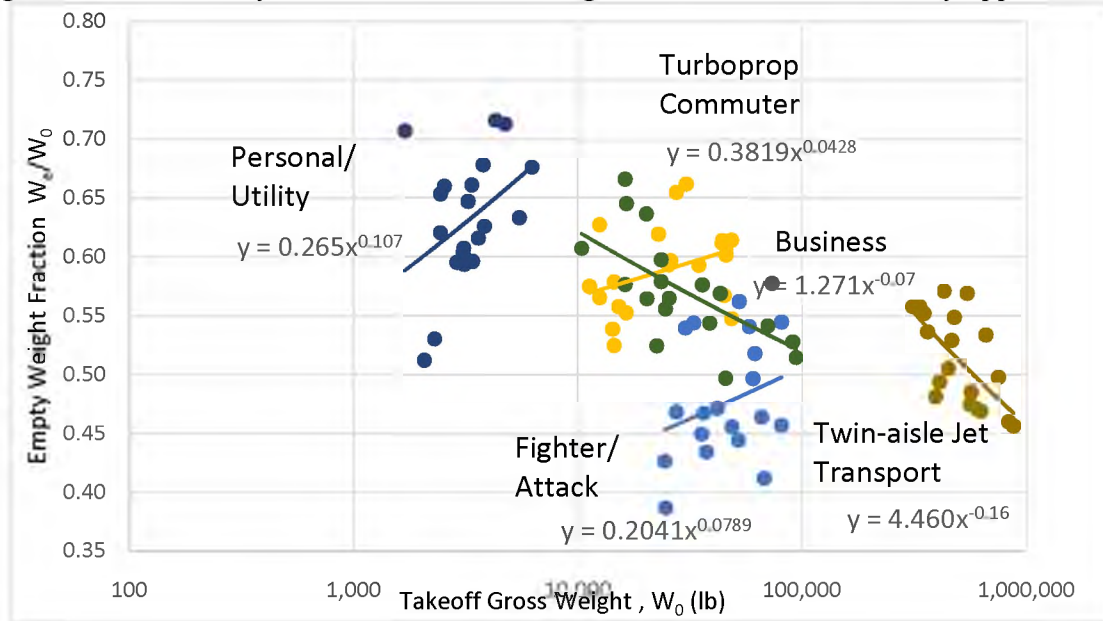

Fig. 4. Empty Weight Ratios using Schaufele data

### 3. PREFERRED APPROACH

Students must understand the significance of Figs. 5 and 6, which are derived from Ref. [2, Fig. 5.5]. They are also a graphical representation of Eq. 1, where the gradient of  $W_{eR}$  is  $(1 - W_f/W_0)$  and the gradient of  $W_{eA}$  is  $G$ . They illustrate that small changes in  $W_{eR}$  or  $W_{eA}$  will make a large change in  $W_0$ . Unless the students' initial estimates of  $L/D$ , sfc, and empty weight required are reasonably accurate, then the estimate of TOGW is likely to be significantly in error. The figure also shows that if the fuel fraction is small and the payload fraction large, then the intersection angle between  $W_{eR}$  and  $W_{eA}$  becomes larger, so that the sensitivity of TOGW to  $L/D$ , sfc, and empty weight ratio becomes smaller. In general, short-haul aircraft do not have the same level of advanced technology as that of long-range aircraft with a small payload fraction. Fig.6 shows that if the payload is negligibly small, and crew (and hence weight of cockpit) can be eliminated, then a very large reduction in TOGW can be achieved for a given mission range. For example, in 2003 an aircraft flew across the Atlantic from Newfoundland to Ireland. Its communication/navigation system included an autopilot, GPS, satellite-based telemetry, and air/ground communications (for local pilots to control the aircraft for launch and landing). The airplane, named TAM-5, weighed 5 kg (11 lb.), and had an empty weight of 2.7 kg (6 lb.) [6]. Flight duration was 38 hours 23 minutes. Fuel burn rate was about 1275 km/l (3000 miles/gal).

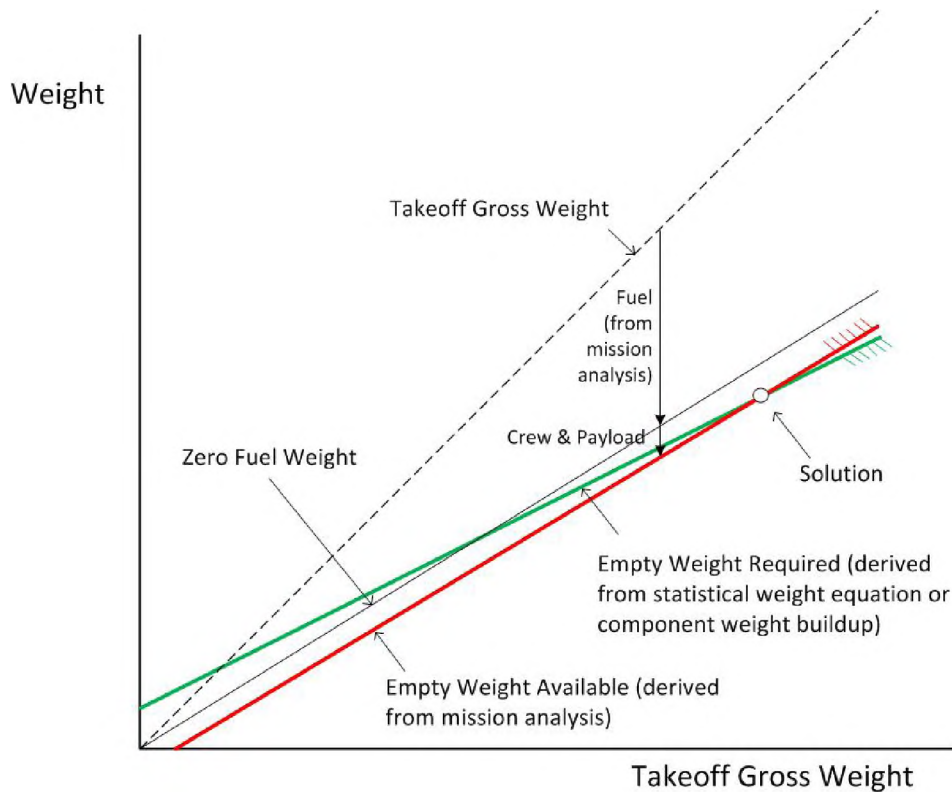

Fig. 5. Equating Empty Weight Required to Empty Weight Available

Spreadsheets have been used for initial sizing and constraint analysis since their introduction to personal computers in the 1980s [7]. In practice, the sizing procedure can conveniently be performed using Microsoft Excel, and an iterated solution obtained using the Solver add-in. For the author's class, a spreadsheet is made available that must be modified by the students to meet the stated design requirements. This may be found at [8]. This spreadsheet can size an aircraft to a given mission requirement, and generate the intersection points on a payload-range plot, but for the initial sizing exercise, only the sheet for determining the TOGW to perform the mission is used.

Almost all the aircraft in the databases to determine empty weight trends use aluminum structures. In Nicolai & Carichner's sizing example for an Advanced Composite Lightweight Fighter, a somewhat arbitrary empty weight reduction factor for composite structure of 0.84 is assumed. Both Raymer (in Section 15.4), and Nicolai & Carichner (in Section 20.2.3) have suggestions for weight reduction factors by structural group (e.g., wing, tail, fuselage, etc.). If the students plan on using composite structure (as is increasing likely) these weight reduction factors must be introduced to students at the initial sizing stage.

In the spreadsheet in Ref. [8], for a commercial aircraft, students can enter the estimated weight reduction factors by structural group. The spreadsheet estimates the weight breakdown by structural group for the calculated empty weight, and applies the weight reduction factor to that weight.

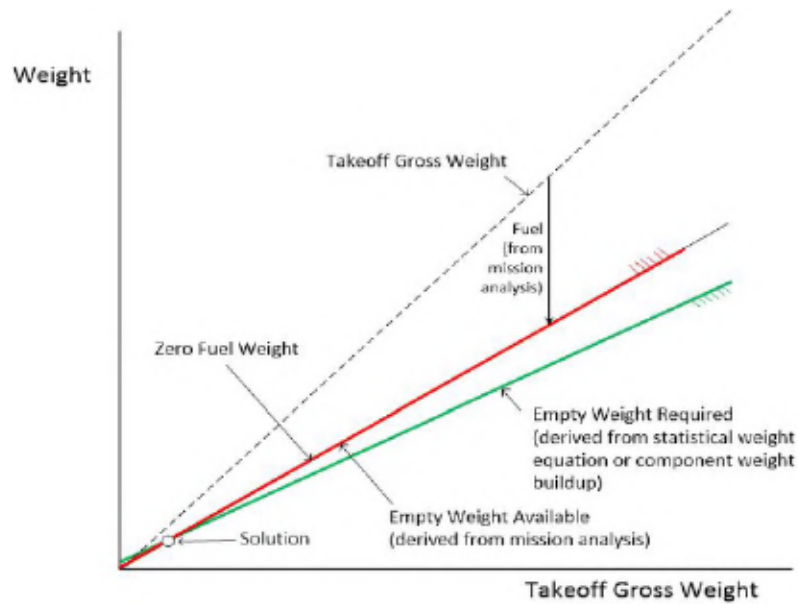

Fig.6. Elimination of Crew and Payload

#### 4. CONCLUSIONS

In an undergraduate aircraft design course, calculating the TOGW of an aircraft to perform a specified mission may appear to be a fairly simple exercise. But it is important that students not only understand the process, but also appreciate the sensitivity of the input variables ( $L/D$ , sfc, and ratio of  $W_{eR}/W_0$ ) to TOGW.

#### REFERENCES

- [1] D.P. Raymer, Aircraft Design: A Conceptual Approach, 5<sup>th</sup> Edition AIAA, 2012
- [2] L.M. Nicolai, and G.E. Carichner, Fundamentals of Aircraft and Airship Design, Volume 1 – Aircraft Design, AIAA, 2010
- [3] R.D. Schaufele, Elements of Aircraft Preliminary Design, Aries Publications, 2007
- [4] J. Roskam, Airplane Design, Part 1 Preliminary Sizing of Airplanes, Roskam Aviation and Engineering Corporation, 1985
- [5] D. McLean, Understanding Aerodynamics, Wiley, 2013
- [6] Anon, Wikipedia [https://en.wikipedia.org/wiki/The\\_Spirit\\_of\\_Butts%27\\_Farm](https://en.wikipedia.org/wiki/The_Spirit_of_Butts%27_Farm)
- [7] A.P. Hays, Spreadsheet Methods for Aircraft Design, AIAA Paper 89-2059, August 1989
- [8] A.P. Hays, <https://www.adac.aero/design-data>
- [9] A.P. Hays, W.E. Beck, W.H. Morita, B.J. Penrose, R.E. Skarshaug, and B.S. Wainfan, Integrated Technology Wing Design Study, NASA Contractor Report 3586, August 1982

**INFORMATION ABOUT THE AUTHOR**



Tony Hays started work in the aerospace industry in 1962 as an apprentice at Bristol Siddeley Engines Ltd. (later absorbed into Rolls-Royce). He earned a B.Sc. from Bristol University in 1965 and an M.S. from MIT in 1971. He has worked for numerous aerospace-related companies in the U.K., Canada, and the U.S. Most of this work was in the area of aircraft advanced design. He has taught classes in aircraft conceptual design at Northrop University, University of California San Diego, California State University Long Beach, and Nanjing University of Aeronautics and Astronautics.

## PIEZOELECTRIC MOTORS FOR MICRO AIR VEHICLE

P. Vasiljev<sup>1,2</sup>, D. Mazeika<sup>1,2</sup>, S. Borodinas<sup>1,3</sup>, J. Qiu<sup>1</sup>

1 – Nanjing University of Aeronautics and Astronautics, Nanjing, China

2 – Lithuanian University of Educational Sciences, Vilnius, Lithuania

3 – Vilnius Gediminas Technical University, Vilnius, Lithuania

Email: [Piotr.Vasiljev@leu.lt](mailto:Piotr.Vasiljev@leu.lt); [Dalius.Mazeika@vgtu.lt](mailto:Dalius.Mazeika@vgtu.lt)  
[Sergejus.Borodinas@vgtu.lt](mailto:Sergejus.Borodinas@vgtu.lt); [Qiu Jianmin@nuaa.edu.cn](mailto:Qiu Jianmin@nuaa.edu.cn)

**Key words:** Micro Air Vehicle, Piezoelectric Motor, Radial-Bending Vibration.

**Abstract:** *Piezoelectric motors for micro air vehicle are presented in this paper. A new design concept of disc type piezoelectric actuator used for small size rotary type ultrasonic motor has been proposed to drive the propellers. Radial-bending type hybrid vibrations of the special disc is employed to drive a rotor. Stator of the actuator has special waveguides in the center that are aligned to the tangential direction of the contacting surface of the rotor. The waveguides are used to transform radial vibrations of the disc into rotational vibrations of the contacting ring. Bending vibrations of the disc is employed to obtain axial vibrations of the contacting surface. Elliptical motion of the contact points is obtained by superposition of the both vibration modes. Two actuators with regular beam waveguides and quadrilateral shape waveguides were analyzed. Both piezoelectric actuators are bimorph type and consist of a steel disc with threaded waveguides and two piezoceramic rings. Numerical and experimental investigation of the piezoelectric actuators was performed to validate operating principle and to analyze vibrations of the contact points. Electrical and mechanical output characteristics of the piezoelectric actuators were measured. Results of investigation were analyzed and discussed.*

### 1. INTRODUCTION

Micro Air Vehicles (MAV) are widely used in both civilian and military purpose[1]. Some of the potential missions for MAVs are visual reconnaissance, situational awareness, damage assessment, surveillance, biological or chemical agent sensing, and communication relay. In addition to these military missions, there are several commercial applications such as search and rescue, border patrol, air sampling, police surveillance, and field research. One of the most important problem for further development of MAV is how to reduce their size and weight which allow MAV to meet more specific requirement. The main components determining their weight and size are motor, control system, and power supply system. It will be a fully challenging work to development a tiny MAV once reduce the dimensions of those components. Following problems appears such as power efficiency of driving engine drops, control difficulty increased, insufficient time of flying.

In a word, basic technical route for future MAV design should be focused on three aspect, create more powerful motor with high power efficiency for driving, development of stable and reliable control system, develop new type of battery which higher energy density. It's a

multidisciplinary and comprehensive research task. After overview of MAVs with their mass less than 10g which developed by companies or labs such as “Picoflyer”[2], “Micro Elicottero”[3], and etc. What they have in common is a short flying time, none of them can last longer than 20 minutes. One of the widely recognized reason is power consumption of the motor. Almost all of their driving engine used DC motor. However, power efficiency of DC motor drops rapidly after miniaturization. To solve this problem we developed a new type piezoelectric motor, that has higher efficiency than DC and can be used for MAV. We mainly focused on mechanical part of MAV in this paper and provide several designs of piezoelectric motors which could be used for MAV engine. First priority of our work is to guarantee that the motor is powerful enough to drive propellers when dimension of the motor are minimized. Small piezoelectric ultrasonic motors can generate a large output torque and to achieve high efficiency [4, 5]. Also they have such advantages such as simple design, lightweight, good controllability of position and velocity, high resolution of displacement. However, the small strain are obtained from the piezoelectric effect, therefore various design and operating principles of the actuators with displacement amplifiers were suggested [7-10].

Usually small size piezoelectric actuators operate based on a standing wave or inertial principle [4, 7]. Relatively small vibration amplitudes of piezoelectric element are amplified using elastic structure so sufficient torque of the motor is obtained.

Small size standing wave rotary motor was developed that operate applying longitudinal vibrations of the plates [7]. It has quite simple design, however a disadvantage of this motor is the non-reversible operation principle. There are a standing wave plate or cylinder type reversible ultrasonic motor developed where reverse motion is achieved by exciting different electrodes of changing phases of excitation signals applied on different electrodes [4, 11]. The inchworm mechanism was utilized for small size rotational piezoelectric motor [12]. The stator of the transducer consists of six multilayered bimorphs that bend and generate sufficient longitudinal deformation to perform elliptical trajectory of the driving tip.

This research focuses on development of a novel design compact bimorph disc type piezoelectric actuator for small size rotary ultrasonic rotor that can be readily manufacturable. However the main goal of a new actuator development was to achieve high rotation velocity of the rotor. Both numerical simulation and physical prototypes were used to verify operating principle and output characteristics of the motor. Results of numerical and experimental investigation are discussed.

## **2. DESIGN OF THE ACTUATOR**

Design of piezoelectric actuator is based on bimorph disc with the special waveguides in the center part of the disc. The waveguides are aligned to the tangential direction of the contacting surface of the rotor. Radial-bending type hybrid standing wave vibrations of the disc are excited and employed to drive a rotor.

The waveguides transform radial vibrations of the disc into rotational vibrations of the contacting ring while vibrations of B30 bending mode of the disc is employed to obtain axial vibrations of the contacting surface. Superposition of these two vibration modes allows to achieve elliptical motion of the contacting surfaces.

Two designs of the actuator were proposed (Fig. 1). Both proposed actuators operate based on the same principle but have different configuration and number of the waveguides i.e. twelve and sixteen. Actuators are named as No.1 and No.2, respectively. Such configurations were chosen in order to investigate influence of the waveguide shape and amount into the output characteristics of the ultrasonic motor. Both actuators consist of a steel disc with the waveguides and PZT-8 ring glued on the top surface of the ring. It must be mentioned that



fabrication price of the actuator is low. Steel disc can be manufactured by CNC laser cutter machine.

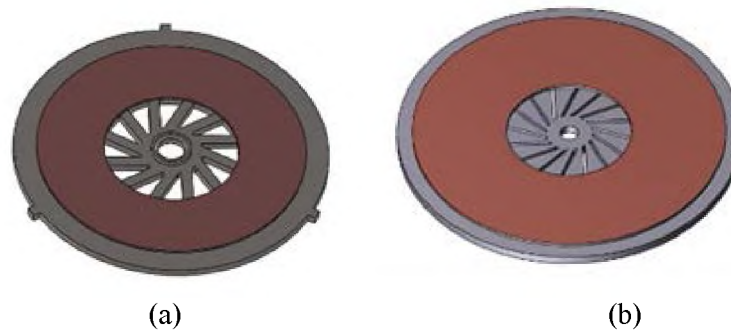

Fig.1. Principle design of the actuator: 12 waveguides (a), 16 waveguides (b)

Outside diameter of the actuator No.1 and No.2 is 23 mm (Fig. 1a) and 22 mm (Fig.1b) respectively while thickness of the both actuators is 0.6 mm. Dimensions of the piezoceramic rings are 20x8x0.2 mm and 20x10x0.2 mm respectively. Dimensions of the actuators were optimized in order to match vibration frequencies of the 1st radial mode and B30 bending mode of the stator. Single channel harmonic signal is used to excite PZT ring.

It should also be noted that design of the actuators can be modified by changing number of waveguides or adding one additional piezoceramic ring with the opposite polarization. Additional ring must be glued at the bottom surface of the disc. In this case, electrodes of the top piezoceramic ring must be divided into two circular parts by ratio  $D_{out}/D_{electrode} = 1.54$  (Fig.2). Dividing line of the electrodes is determined by the nodal circle of the B30 bending mode of the disc. Two harmonic signals with shifted phases by  $\pi$  are applied on different electrodes and are used to excite hybrid vibrations of the modified actuator.

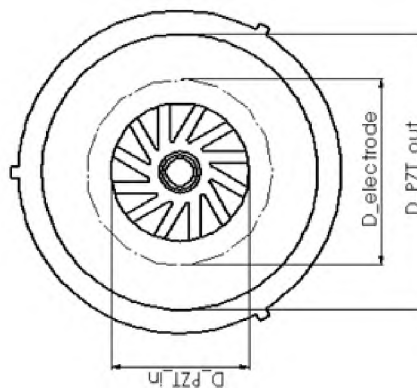

Fig.2. Electrode topology when two PZT rings are used

Numerical simulation of the both actuators was performed to validate operating principle and to compare trajectories of the contact point motion. Numerical modelling based on the finite element method was performed to confirm operating principle of the actuator. FEM software COMSOL Multiphysics was employed for the modelling and simulation. Finite element model of the actuator was built using three-dimensional free tetrahedral finite elements. No mechanical constraints were applied in the model. The following materials were used for FEM model: PZT-8 was used for modelling piezoceramic rings, steel X20Cr13 was used for the disc parts.

Geometrical parameters of the disc and waveguide were adjusted in order to match the 1st radial mode and B30 bending mode of the disc actuator. Modal shapes of the actuators used to drive a rotor are presented in Fig. 3. It can be seen that contacting surface have rotational and axial vibrations as it was expected.

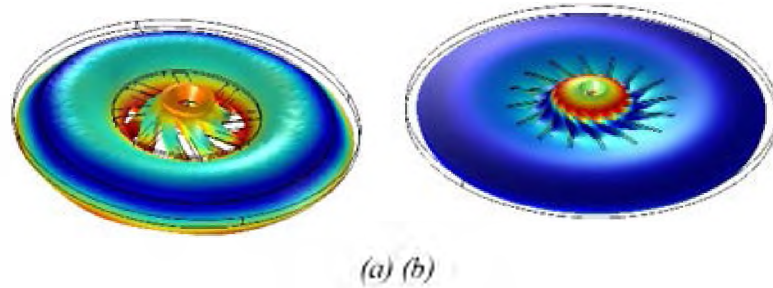

Fig.3. Modal shapes of the actuators at resonant frequencies 97.3 kHz and 100.9 kHz

Harmonic response analysis was performed with the aims to find out the actuator's response to sinusoidal voltage and to compare vibration amplitudes of the contact points when different number of the waveguides is used.

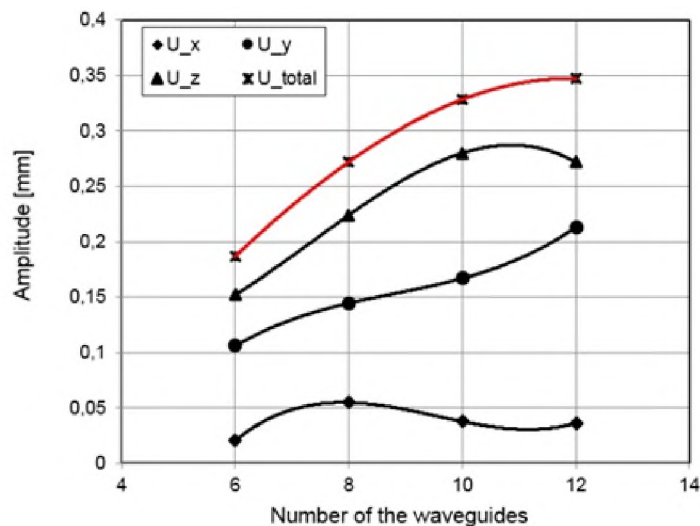

Fig.4. Dependence of the vibration amplitude from number of waveguides

The actuator No.1 with two piezoceramic rings was chosen for investigation when number of the waveguides were changed from 6 till 12 with the step 2. Excitation scheme of the electrodes were used as shown in Fig. 2. Harmonic signal of 50V was applied for simulation. Results of calculated amplitudes in xyz directions are presented in Fig.4. It can be seen largest vibrations amplitudes are achieved when actuator has 12 waveguides.

Contact point trajectories of the actuator No.1 in yz plane were investigated as well (Fig.5a). It can be seen that trajectories have elliptical shape and length of the major and minor axes depends on the number of the waveguides. The largest length of the major axis is obtained when number of waveguides is equal to 10 however largest ratio between major and minor axes is when number of the waveguides is 12.

Numerical simulation of the contact point trajectories of the both actuators was performed when just one piezoceramic ring was used. Vibrations of the both actuators were simulated at their resonant frequencies. Contact point trajectories in yz plane are shown in Fig.5b. It can be

noted that the both trajectories are closed to the straight line. Trajectory length of the actuator No. 2 is 1.36 times larger than the trajectory length of the actuator No.1 therefore larger rotation velocity of the rotor will be obtained.

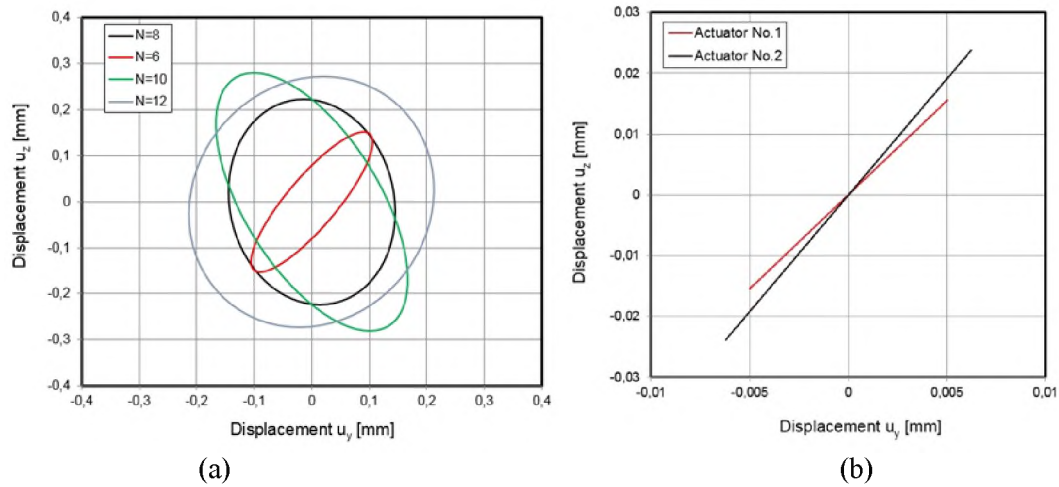

Fig. 5. (a) Trajectories of contact point motion in and yz planes of the actuator No.1 ;  
(b) Trajectories of contact point motion in yz planes of the both actuators

### 3. RESULTS OF EXPERIMENTAL MEASUREMENTS

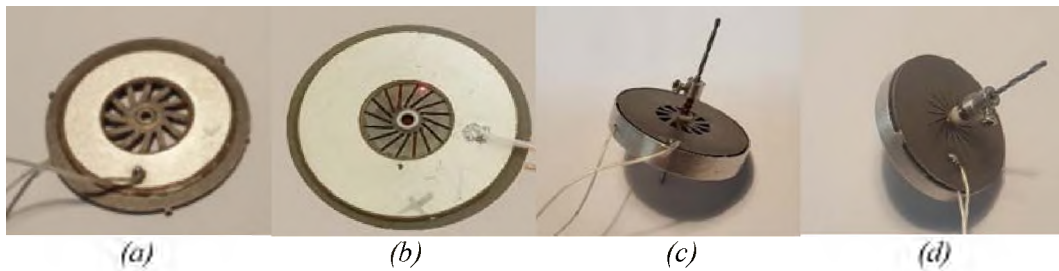

Fig. 6. Prototype actuators (a, b) and prototypes of piezoelectric rotary motors (c, d)

The aim of experimental study was to validate operating principle of the actuator and to perform measurements of mechanical output characteristics. The both prototype piezoelectric actuators were made (Figs. 6a, 6b). Materials mentioned in the previous section were used for prototype fabrication. The weight of the actuator No.1 and No.2 is 2.1 g and 2.2 g, respectively. A special holder with the bearing was designed for each actuator. Cone type rotor was fabricated from alumina. Alumina ring was glued on the top surface of the actuator in order to increase contact stiffness between rotor and actuator. Preloading of the rotor was performed using spring. Prototype piezoelectric rotary motors are shown in Figs. 6c, 6d.

The impedance-frequency characteristic of the actuators was measured in frequency range of 95-105 kHz. Impedance analyser Agilent 4294A was used for the measurement. Operating resonant frequency of the actuator No.1 and No.2 was found at 98.57 kHz and 98.44 kHz, respectively (Fig. 7a). The error between the measured and calculated frequencies does not exceed 2.43% and mainly comes from the FEM simulation, such as the inaccuracy of the material properties and not considering the glue layer.

Rotation velocity of the both piezoelectric motor was measured as well. Non-contact laser tachometer Monarch PLT200 was used. (Fig. 7b). represents dependence of the rotation

velocity from excitation voltage. Measured velocity is presented as discrete points. Analyzing results it can be seen that the rotation velocity has almost linear dependence from the input voltage and achieves maximum values of 2330 rpm and 3880 rpm for the actuator No.1 and No.2, respectively. It must be noticed that difference between velocities mainly comes because of the dimensions of piezoceramic ring and configuration of the waveguides.

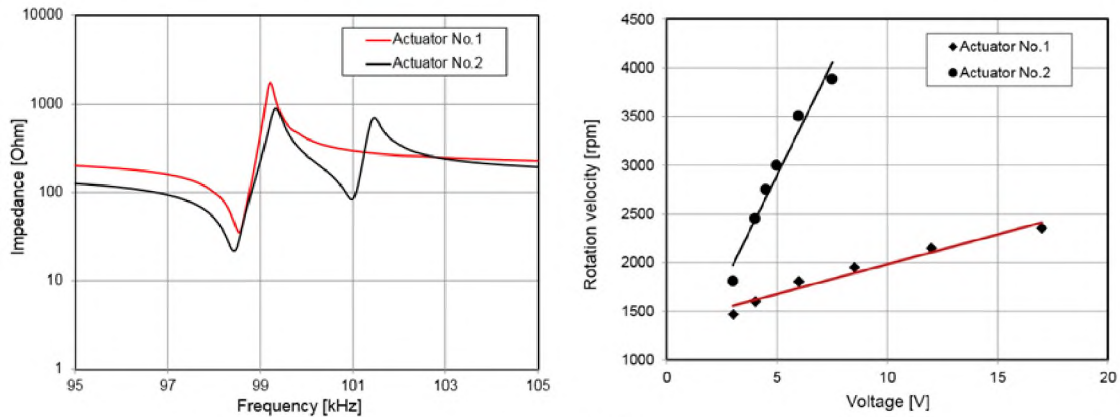

(a) (b)

Fig.7. (a) Measured impedance versus frequency (b); Measured rotation velocity versus input voltage

#### 4. DISC TYPE MOTOR USED IN MINI HELICOPTER

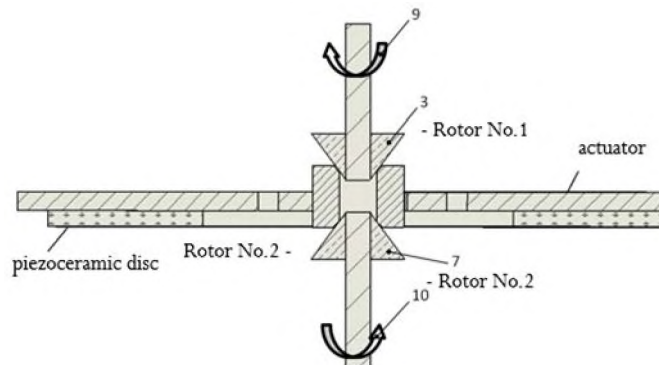

Fig.8. Schematic diagram of single motor drive two rotors rotate in different direction

Disc type piezoelectric actuator can also achieve two output motions by using hybrid mode. The schematic diagram of single motor used to drive two rotors in opposite directions is shown in Fig.8. The hybrid mode including first mode of radial vibration, bending vibration mode of the disc, first longitudinal mode of waveguides and twisting vibrations of the cylinder. Hybrid mode of the actuator excited by unsymmetrical position of piezoceramic disc, top and bottom surfaces of the contact cylinder produce elliptical trajectories. However, motion of the contacting surfaces has opposite direction because of the different phases of multimode vibrations which is a unique advantage for micro helicopter design. Such property of the motor does great help to reduce the weight of MAV. Fig.9b and Fig.9c shown the disc motor driving double propellers rotate in inverse direction and locate in same and opposite side of the plate body.

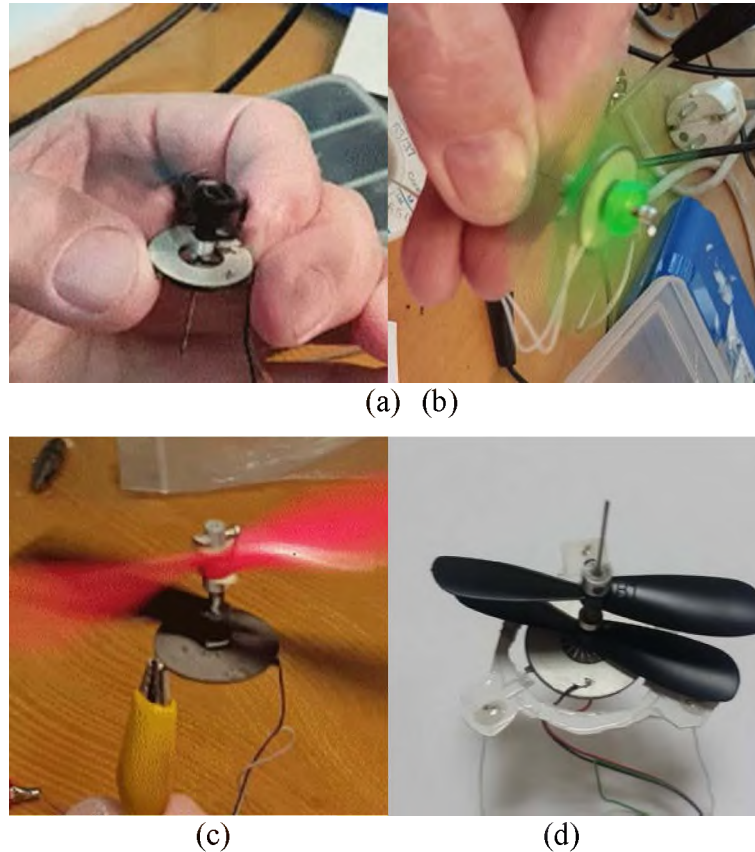

Fig.9. (a) Disc type motor for single propeller. (b) Disc motor for double propellers in opposite side ; (c) Disc type motor for double propellers in same side. (d) Prototype of micro helicopter

## 5. CONCLUSIONS

Novel design concept of disc type piezoelectric actuator for small size rotary type ultrasonic motor was proposed. Rotation of the rotor was achieved employing radial-bending type hybrid vibrations of the special disc with the waveguides. Results of numerical simulation and experimental study validated the operating principle of the actuator. Vibrations amplitudes and trajectories of the contact points depend on number of waveguides of the disc. Maximum rotation velocity of 2330 rpm and 3880 rpm was achieved for the actuator No.1 and No.2, respectively. Structure configuration of the micro helicopter by making use of disc type motor has been proposed and the possibility of such idea also proved by experiment test.

## REFERENCES

- [1] Grasmeyer J, Keennon M. Development of the Black Widow Micro Air Vehicle[J]. Aiaa Aerospace Sciences Meeting & Exhibit, 2001.
- [2] <http://www.ohgizmo.com/2006/03/28/picoflyer-worlds-smallest-rc-copter/>
- [3] <https://www.ebay.com.hk/itm/Micro-Elicottero-Robbe-Arrow-210-irofly-x-iphone-S2527/132732926482?hash=item1ee77fba12:g:Oq0AAOSwTM5Y3Nxi>
- [4] Uchino K., Giniewicz J. Micromechatronics. CRC press, 2003.
- [5] Ch. Zhao, Ultrasonic Motors: Technologies and Application, Springer, Beijing, 2010.

- [6] Morita T. Miniature piezoelectric motors, *Sensors and Actuators*, Vol. 103, Issue 3, 2003, p. 291-300.
- [7] Y. Suzuki, K. Tani, T. Sakuhara. Development of a new type piezoelectric micromotor. *Sensors and Actuators A*, 83 (2000), pp. 244-248.
- [8] C.L. Sun, K.H. Lam, H.L.W. Chan, X.Z. Zhao, C.L. Choy. A novel drum piezoelectric-actuator. *Applied Physics A*, 84 (2006), pp. 385–389.
- [9] H. Fang, L. Liu, T. Ren. Modeling and design optimization of large-deflection piezoelectric folded cantilever microactuators. *IEEE Transactions on Ultrasonics, Ferroelectrics, and Frequency*. 53(1) (2006), pp.237-240.
- [10] Ch. Yang, S. Liu, X. Xie, C. Livermore. Compact, planar, translational piezoelectric bimorph actuator with Archimedes’ spiral actuating tethers. *Journal of Micromechanics and Microengineering* 26 (2016), pp. 1-10.
- [11] A. Iino, K. Suzuki, M. Kasuga, M. Suzuki, T. Yamanaka. Development of a self-oscillating ultrasonic micro-motor and its application to a watch. *Ultrasonics*, 38 (2000), pp. 54-59
- [12] M. Bexell, S. Johansson. Characteristics of a piezoelectric miniature motor. *Sensors and Actuators A*, 75 (1999), pp. 118-130.

### Authors



Piotr Vasilev



Dalius Mazeika



Sergejus Borodinas



Jianmin Qiu

## ONLINE LEARNING IN AERONAUTICAL ENGINEERING EDUCATION AT SOME AMERICAN UNIVERSITIES

Stephane Tambwe<sup>1</sup>, Oleksiy Chernykh<sup>2</sup>, Dmytro Tiniakov<sup>3</sup>

1,2,3 – Nanjing University of Aeronautics and Astronautics

College of Civil Aviation

29 Jiangjun Avenue

Nanjing, 211106, Jiangsu, China

e-mail: 1 – 2489165194@qq.com

2 – alex@nuaa.edu.cn

3 – tinyakov\_dm@mail.ru

**Key words:** Online course, online learning, distance education, aeronautical engineering.

**Abstract.** *Online courses are becoming more popular, not necessarily because the learning is better, but rather due to convenience. The purpose of this paper is to demonstrate how the learning process happens, how it can be applied when it comes to learning the aeronautical engineering, and at what cost. As an example, there were five universities in the U.S.A. compared offering their detailed description, admission conditions, graduation requirements, teaching statistics. They are the LeTourneau University, the North Carolina State University, the Embry-Riddle Aeronautical University, the Eastern New Mexico University, and the Hampton University. The studying process, including forum discussions, personal portfolio management, assignments, and examination, has also been described. Suggestions on how to organize self-learning have been provided.*

### 1. INTRODUCTION

Distance or online learning is a mode of study that allows students to study most or all of a course without attending at a campus-based institution. Distance can refer to both material and interaction. Distance learning provides access to learning when the source of information and the learners are separated by time and distance, or both.

During this type of education students communicate with the faculty and other students via e-mail, electronic forums, video-conferencing, chat rooms, bulletin boards, instant messaging and other forms of computer-based interaction.

The programs often include an online training system and tools to produce a virtual classroom. The tuition fees for distance learning vary from institutions to programs or countries. It is certain that the student saves expenses related to accommodation and transportation, because one can maintain one's current living expenses. Distance learning is also a great solution for people that already have a job, and still want or need further education.

There are three primary advantages of online learning:

- **Accessibility:** a course is open to a student 24/7 during a semester. A student only needs access to the internet to log in.

- Flexibility: a student can arrange learning around one's life's schedule. Or, add an extra class to one's on-campus schedule.
- Affordability: No need for commuting costs to campus, or for resident hall expenses.

## **2. ONLINE COURSES IN AVIATION**

An online class in aviation could focus on safety, communication, technology, navigation, ground support, aircraft systems, flight theory, physics, simulation, maneuvers, security, meteorology, aviation emergency, or air law. Depending on the goal students have in mind, they could choose a course that focuses on the abstract theory of flight, the concrete skills of piloting, the science of a ground crew, or other areas of knowledge related to aviation. The course could be centered on private piloting or commercial airlines.

While a piloting license almost always requires students to complete practical flight training, the skills students learn in an aviation course can help them prepare for flight schools. An aviation class may also teach valuable skills, such as staying calm under pressure, hospitality, or special awareness.

Aviation course costs vary depending on a country and a school. Students should contact the school of their choice to find out the price and whether scholarships are available to them.

By taking a course in aviation, you may be able to start your way toward a career as an avionics technician, ground staff member, commercial or transport pilot, cabin crew member or coordinator, dispatcher, in-flight medic, or navigator. You may also be able to pursue a private pilot's license. Many career paths in aviation do not involve piloting; a warm personality and a course in cabin crew training could lead to a position as a steward or stewardess, or a knack for communications and a course in dispatching could lead to a job at a flight terminal.

## **3. TESTS, EXAMS AND ASSIGNMENTS**

Online studies are usually divided into four main parts: forum discussions; maintaining a personal portfolio; writing assignments; preparing for exams and a final exam itself (MCQs). Students will need to go through each of these sections in order to pass their course. A final mark is usually calculated at the end of the term over one's performance. An example would be 20% on the performance in discussions, 30% for the assignment, 30% for the portfolio and 20% for the final exam.

### **3.1. Forum discussions**

The main subject is spread among various topics. For example, if the main subject is Creative Writing, this is divided into plot, structure, narrative techniques, language etc. Similarly, the subject chosen by a student will also be divided into other smaller discussion topics.

To be able to make high-quality contributions to discussions, a student has to go through various websites and online journals to get relevant information which others have not discovered, which he/she should present in own words.



A supervisor will be following the student's comments every 2 or 3 days and he or she will point out mistakes. This will be visible to all the students of the group. That's why it is important to write the text, save it and check for mistakes before submitting.

The marks are given for the total number and quality of discussions that a student had during a course. That means the more a student is active the better the score will be. Discussions can be a bit time consuming, but, the student will notice that the new information he/she is gaining through the forum is enormous.

### **3.2. Maintaining a personal portfolio**

When a student discusses a topic in the forum, he/she can enter key learning points in a personal portfolio. Such a portfolio represents personal reflections on what one has learned in the discussion.

It shows to an examiner how much knowledge a student has gained and how he/she will use it in daily practice. In general, a supervisor will check student's entries every week and will comment on the material.

### **3.3. Writing assignments**

For each course, a student needs to complete one assignment on a topic which will be given to him by a supervisor. Usually, a student can choose from several topics provided, e.g. a choice of 3 or 4 topics. As opposed to one's portfolio, in most cases a student will receive feedback only at the end of the term, when results are announced.

What's always a good idea is to start working on an assignment as soon as possible. A student could be doing this by adding to it every day until one completes the subject.

### **3.4. The exam**

Finally, there will be an online exam, also known as the MCQ (computer-administered Multi-Choice Question examination). Exam dates will be announced some time before and a student usually gets a 48-hour window to sit for an exam.

The great side of online studies is that a student will have open book exams, meaning he/she may use any material available. Of course, using own notes is a huge advantage, but he/she might want to quickly search online for some additional facts. The questions will cover the same topics discussed in the forum.

In general, the MCQ will be a score of correct answers out of 20 in total. For example, a student may be expected to get 12 out of 20 to pass. Of course, each university would set its own passing grades and rules.

## **4. APPLICATION OF ONLINE DEGREE IN DIFFERENT INSTITUTIONS**

Different universities might have specific courses which can be found online, not all the universities have the possibility to give a degree after taking courses online. But here we will give details on some of the best institutions in the United States which, apart from allowing a student to get a degree after taking courses online, offer aeronautical studies. The institutions are given further.

#### **4.1. LeTourneau University (LETU)**

An interdenominational Christian university in Longview, Texas, LETU offers online aviation degree programs in aviation science and aviation management. For the past five years, National Intercollegiate Flying Association has designated LETU's aviation programs as the best in the nation.

Each accelerated aviation program requires 120 credit hours, including 42-48 hours of major courses, 30 general education hours, 30 elective hours, and 12 hours of theology and vocation courses. LETU students must maintain a GPA of 2.0 or better.

The aviation science program requires courses in aviation management, aviation safety factors, financial analysis, and business ethics. Graduates often pursue careers in airport management, aircraft maintenance management, and aviation operations coordination.

The aviation management program includes courses in aviation human factors, aviation safety, airport operations and management, and air transportation systems. Students in this program can choose to pursue a concentration in maintenance, air traffic control, or professional piloting, though only the maintenance concentration is available online. Many graduates pursue careers in airline operations, airport operations, and maintenance management.

Each online course lasts three to seven weeks and students typically take one course at a time. Professors assign coursework each Monday, with deadlines each Sunday. Full-time students complete the entirely online programs in two years. LETU accepts transfer credit and awards credit for military experience.

#### **4.2. North Carolina State University (NC State)**

Founded in 1887 as a school for agriculture and mechanic arts, NC State offers a bachelor's of science in aerospace engineering that prepares students to design, manufacture, and analyze space systems and aircraft. Students complete coursework in aerodynamic design and performance, aerodynamic structures, rocket and air-based propulsion systems, and engineering materials and dynamics.

The degree requires 127 credit hours. Students complete a two-semester capstone course with two project options: students can design and fly a unique, remotely controlled aircraft or design, build, and operate a space system, such as a satellite, remotely controlled space probe, or moon-rover vehicle.

Students earning the aviation bachelor's degree online can choose the accelerated format to earn both a bachelor's and master's degree in aerospace engineering in five years. NC State also offers a direct path from the bachelor's program to the doctoral program in aerospace engineering. NC State students must maintain a GPA of 2.5 or above and earn a grade of C or better in each required course. NC State invites sophomores and juniors with a GPA of 3.5 or better to participate in a program-specific honors program. Honors students must maintain an overall GPA of 3.25 or better to graduate with honors.

#### **4.3. Embry-Riddle Aeronautical University (ERAU)**

Located in Daytona Beach, Florida, ERAU offers an online bachelor's degree in aviation; the Bachelor of Science in aeronautical science curriculum is designed for military members and active professionals in the aviation industry.

The fully online program requires 120 credits and takes most students 3 years to complete. Students customize their degree through more than 500 aviation course options. The curriculum covers topics in general aeronautics and applications, general aeronautical science, airframe systems and applications, aircraft electrical systems theory, private pilot operations, and airman knowledge test preparation.

Each student works with a faculty member to formulate and complete an aviation maintenance capstone project over a two-month period. Graduates pursue careers in air traffic management, meteorology, safety, and business. Available minors include air cargo management, emergency services, and unmanned aerial systems.

ERAU awards credit — up to one quarter of the degree's requirements — for prior aviation experience. ERAU considers all aspects of an applicant's qualifications, including previous experience. The school also offers a combined bachelor's to master's degree in aeronautical engineering for students interested in earning both degrees in 5 years of full-time study.

#### **4.4. Eastern New Mexico University (ENMU)**

Located in Portales, ENMU offers two bachelor's degrees in aviation science: a bachelor's of science in aviation science and a bachelor's of applied arts and science (BAAS) in aviation science.

Each program requires 120 semester hours, including 38 general education hours, 28 major hours, and 19 hours of required complementary courses. Students customize the curriculum through electives. Students in both programs complete a senior seminar and core coursework in economics, computer skills, spreadsheets and data analysis, and statistical methods.

The bachelor's in aviation science degree requires courses in aviation history, flight theory, and FAA regulations. The BAAS requires courses in aviation law, airport operations, and contemporary aviation issues. Transfer students in this program can apply up to 64 credits earned at another accredited institution towards their degree. Up to 58 of those credits can be used to satisfy the program's technical emphasis area requirement.

Students take a general education assessment after completing 55 to 75 hours. Students must maintain a GPA of 2.0 or better. All program requirements are available fully online. Applicants to the BAAS program must have aviation industry experience, an FAA certificate or license, or at least 30 transfer credits.

#### **4.5. Hampton University (Hampton U)**

Located in Virginia, Hampton U is a historically black university that was founded in 1868. The school offers a range of online programs, from certificates and associate degrees all the way through doctoral degrees. The school's Bachelor of Science in aviation management, airport administration program combines aviation skills with a liberal arts foundation. The 122-credit program includes courses in aviation foundations, airport systems, weather and climate, flight safety, airport operations, aviation history, and homeland security.

During each of the first six semesters, students complete a one-credit, pass-or-fail aviation seminar. The school delivers its program asynchronously through the Blackboard platform. Students complete a three-credit practicum during their final semester. Graduates often pursue airport and airline management positions.

Hampton U offers financial aid, scholarships, and veteran’s benefits. All online students pay the same flat tuition rate, regardless of residency. Prospective students must check the school's state eligibility list to ensure their state of residency is among the 28 states in which Hampton U offers its programs. Applicants must have a high school diploma or GED and must submit an essay on their professional goals along with official transcripts. Transfer applicants must have a GPA of 2.0 or better. The school offers credit for military and corporate training, transfer credits, and work/life experience.

**4.6. Comparison**

Table 1. Summary comparison

Name of University	Number of Online Degree programs	Total credit to graduate	Duration of the program	Numbers of Online Students	Tuition Fees per programs
LeTourneau University	16	120 credits	2 years or more	1604	\$9,585 ~ \$12,825
North Carolina State University	37	127 credits	1 year or more	2750	\$3,171~ \$11,347
Embry-Riddle Aeronautical University	48	120 credits	3 years or more	12857	\$8,570 ~ \$9,000
Eastern New Mexico University	30	120 Credits	2 years or more	4178	\$11,693 ~ \$12,408
Hampton University	24	122 Credits	3 years or more	4646	\$12,580 ~ \$25,442

**5. CONCLUSION**

As we can see the evolution of technology can also move into the education area, this is why it is important for at least each university to start including online teaching in their programs. It doesn’t have to be global directly, even commencing with students on campus, encouraging them to do assignments or even quizzes online. From that, students will develop ability to learn faster even if teachers don’t talk about certain topics in class. Since we live in a medium where the internet is taking over in every area, it’s important for the future of aeronautics to recruit students from younger age by making some free classes accessible online, where they would have brief introduction on each department of aeronautics and astronautics, and see the benefits of being an aeronautical engineer. For those who have already advanced, they can always have access to some topics which could be important in the career they are going to pursue or in some adjacent specific research areas.

To finish, it is also important how to get the most out of online courses, and we can put that into 5 factors, which are:

- Know your why,
- Establish a good learning environment,
- Be organized / use the resources,
- Communicate Your Boundaries,
- Schedule and stick to a specific time to work on the course.

## **REFERENCES**

[1] <https://courses.edx.org>

[2] <https://www.udemy.com/>

[3] <https://www.coursera.org/>

[4] <https://www.onlinestudies.com/>

[5] <https://www.distancelearningportal.com/>

[6] <https://online-learning.tudelft.nl/>

[7] <https://alison.com/>

[8] <https://www.collegetuitioncompare.com/online>

[9] <https://www.aiaa.org/>

[10] Alexander, S. [2001], "E-learning developments and experiences." Education + Training Vol. 43(4,5), pp. 240-238

### Authors



Stephane Tambwe



Oleksiy Chernykh



Dmytro Tiniakov

### INFORMATION ABOUT THE AUTHORS

**Stephane Molongo TAMBWE** is currently a second-year master student at the Nanjing University of Aeronautics and Astronautics in the College of Civil Aviation where he is doing Airworthiness Technology and Management major. At the age of 23 years he graduated in Aeronautical Engineering (Aircraft Design and Engineering) and the graduation thesis topic was on “Non-destructive methods used for crack detection during initial and continued airworthiness management”.

**Oleksiy Chernykh** has completed his PhD at age of 27 years old at the National Aerospace University of Ukraine, Kharkov city. He is an Assistant Professor of Department of Civil Aviation Engineering (Nanjing University of Aeronautics and Astronautics, College of Civil Aviation). He has published about 10 papers in reputed journals, and reported 14 conference presentations.

**Dmytro Tiniakov** is an Associate Professor at the Department of Civil Aviation Engineering (Nanjing University of Aeronautics and Astronautics, College of Civil Aviation). Before, he also worked at the National Aerospace University "Kharkiv Aviation Institute" in Ukraine. The idea to develop online learning at the Nanjing University of Aeronautics and Astronautics has originally come from him. One of his present research projects is “The analysis of the sources of aircraft noise and development of solutions to reduce the noise in accordance with ICAO requirements”.

## AIRCRAFT FEATURES WITH AMPHIBIOUS' CHASSIS

Victor Morozov<sup>1</sup>, Gabriel Andriamanantena<sup>2</sup>

1 – Nizhny Novgorod State Technical University,  
“Aerorick” Enterprise, Ltd, Nizhny Novgorod, 603035, Russia  
e-mail: [vpmorozovnn@mail.ru](mailto:vpmorozovnn@mail.ru)

2 – Nanjing University of Aeronautics and Astronautics, College of Aerospace Engineering,  
29 Yudao St., Nanjing 210016, P.R.China  
e-mail: [tyga26@qq.com](mailto:tyga26@qq.com)

**Key words:** air cushion landing gear, design, analyzing of aircraft, air amphibians

**Abstract.** *Creation of aircraft without airfield use as the chassis of the device allowing to land on water, ground surfaces is analyzed. The focus is on aircraft with air cushion landing gear.*

### 1. INTRODUCTION

Amphibious vehicles are vehicles that are capable of moving in different types environments, which basically means that they can move on a solid surface (ground, snow, ice), on water and in the air. Amphibians are usually classified in two types which are land and air transport vehicles.

Air amphibians are aircrafts that differ from ground amphibians by much greater cruising speed, starting from the ground or from water it takes no more than 3-5% of the time and covers 0.1-0.05% of the distance from the air route. The main part of the route air amphibians spend in a state of flight in the air.

So by amphibious aircraft, we can basically understand the property of the aircraft based to steer, to take off and to land both on the water surface and on land airfields. Amphibian is not synonymous with patency, it is determined by two-medium basics (amphibios, in Greek, leading a double lifestyle).

Conditional synonym of permeability for amphibians seaworthiness is defined by the maximum wave's height up to which is possible to takeoff from water. One of the main features of the air amphibious is its Takeoff and Landing Device (TLD).

The chassis is a type of TLD, which means the Totality of all elements of the aircraft designed to ensure the transition of the aircraft from the Parking position on the ground to the flight position in the air, and Vice versa, as well ensuring the necessary movements of the aircraft on the ground near the airfield. A simplified classification of TLD:

- TLD providing a change of lifting force;
- TLD providing the change of the longitudinal acceleration;
- TLD providing traffic on the runway.

Under the TLD changes the lift force (TLD of the first kind) refers to all kinds of devices that creates a vertical force, whether it is a powerful mechanization of wings, spoilers, or a helicopter rotor.

TLD changes in longitudinal acceleration (TLD of the second type),it includes all types of aircraft devices, except for the main engines for creating acceleration on takeoff or braking on run (booster engines, powder accelerators, spoilers, brake parachutes, etc., except wheel brakes).

TLD ensure movement on the runway (TLD of the third type),it precisely includes chassis and can be differentiate from the traditional as contact and contactless.

The definition of "contactless" chassis was first introduced by Aircraft designer Robert Bartini in the mid-1970s. Today we know two types of non-contact chassis

- air cushion chassis (ACC)
- and magnetic cushion chassis (MCC).

American engineers for deck aviation have been facing the problems of MCC for a long time. "Non-contact chassis" differs from conventional types of chassis in the way that it has more uniform distribution of loads from the reaction of the support surface to the aircraft structure, approximately an order of magnitude lowers the level of pressure on the surface of the airfield and in some ideal cases, guarantees gap between the aircraft chassis and the airfield surface.

## 2. MAIN PART

### About air amphibians

Air amphibians, in turn, can be divided into three groups:

- Seaplanes amphibian,
- Ground effect vehicles (Ekranoplans) amphibian,
- Aircraft with air cushion landing gear (AACC).

The first subclass of amphibious seaplanes is widely known . nowadays , there are practically no examples of "clean" seaplanes (except for float ones) in the world that do not have wheel landing gear for landing on runways of a ground airfield.

Russia has traditionally been a leader in the development of seaplanes, which is associated with outstanding scientific and technical achievements of the leading design in school of Russia Company TANK them. G. M. Beriev. The most modern Russian seaplanes amphibians include Be-40 and Be-200, Fig.1. Currently, only developed in Russia and there are about a dozen light amphibious sea planes in operation , such as Be-103, LA-6, LA-8, Che-22, Corvette and others.



*a*



*b*

Fig.1. Amphibious seaplanes, boat type: *a* – A-40; *b* –Be-200

The second subclass is amphibious wig. In order to significantly improve the performance of patency, R.E. Alekseev developed a pneumatic chassis, together with a blower ( air cushion under the wing),it allowed the new generation of ekranoplans not only to go to the unequipped shore without concrete slips, but also to take off from a hard surface, such as snow and ice. The



most typical example of amphibious ekranoplan of new generation is "boat-ekranoplan" "Volga-2", which was produced by a small batch at the Nizhny Novgorod aircraft factory "Sokol" – Fig.2,*a*. It was created as a small 8-seater ekranoplan at the same time as a flying model of a large passenger amphibious ekranoplan "Rocket-2", developed By R.E.Alekseev (Fig.2, *b*).

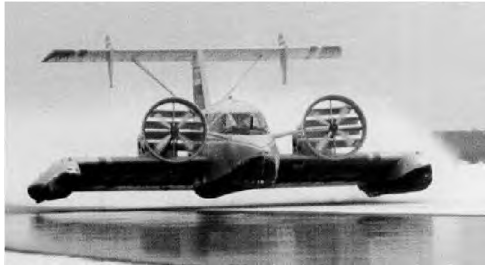

*a*



*b*

Fig.2. Amphibious ekranoplans developed at the ThKB SPK: *a* – a ground effect vehicle "Volga-2"; *b* – the river passenger winged "Rocket-2" (project)

A third subclass we have the aircraft with the landing gear on an air cushion (AACC) which appeared before the wig. For example, the experimental AACC UT-2 was created and tested in 1940. In the 1970 in the USSR carried out a research work on AACC on the basis of an An-14. In 1970, research ballscrews on converted aircraft were conducted, Fig.3. A significant step forward in this direction is considered to be built at the Nizhny Novgorod aircraft plant "Sokol" multipurpose AACC "Dingo" (Fig. 3, *b*). This aircraft differs from other experimental aircraft in a way that it originally built a multi-purpose aircraft project "around the chassis on an air cushion" and at the initial stage of design takes into account the reliability, safety and features of ACC.



*a*



*b*

Fig.3. Aircraft with air cushion chaise: *a* –Lake-4; *b* – Dingo

### About air cushion chaise

Air cushion (AC) inlanding gear is the most radical and at the same time the most structurally complex type of landing gear for the class of AIRCRAFT in question. Unlike contact types, the ballscrews is practically not connected with the hardness of the soil. The positive qualities of ACC can be listed as listed next :

1. the ability to operate aircraft with ballscrews on unpaved airfields in the entire range of soil strength from "zero" liquid state to concrete and asphalt runways.
2. The ability to land on natural sites with a variety of surface types (soil, sand, pebbles, turf, swamp, snow, ice, water, silted ponds and any combination of these surfaces.)

3. The ability to take off and land on snow strips with any thickness of fresh snow and any of its condition (from fluffy to ice crust).
4. A significant increase in the height of the surmounted irregularities (from 30-50 cm for light AACC and up to 1.5 -2.5 meters of heavy transport one's).
5. Overcoming of ditches and cracks of the big sizes, (several times exceeding the admissible sizes of cracks for the ski chassis),
6. Possibility of landing on water with unknown depths, with shallows and small rapids.
7. Possibility of access from the water to the shore without a special concrete slip.
8. Possibility of year-round operation on reservoirs, in the summer and in the winter, including, during formation and thawing of ice.
9. The possibility of landing on water bodies in flood conditions, including floating ice floes, small debris, individual small logs, etc.
10. Highest level of environmental ACC, leaving almost no track, and are vulnerable not Deplete the soil like tundra moss, etc.
11. High energy consumption and excellent shock absorption characteristics of ACC, which in turn reduce the risk of exceeding the permissible overload when landing on unfamiliar sites.
12. A significant reduction in concentrated loads on the airframe during landing, increasing the overall life of the airframe, compared with the wheel chassis, when operating on unpaved airfields.
13. Less dependence on the strength of the crosswind during landing (greater weather minimum).
14. High operational flexibility (ability to perform transport tasks in a variety of home-based scenarios).

AACC have "omnivorous" and "super conductivity" properties, which dramatically expands the conditions of the home and gives the aircraft a unique operational flexibility. Ultimately, the ACC leads to a significant reduction in operating costs in regions with low density of airfield infrastructure, or where its maintenance is not economically achievable .

Aircraft ball screws allow the provision of transport without considerable additional cost of creating local airfield infrastructure.

In the apt words of British designer Thomas D. Earl, (developer of the first North American AACC acquire the properties "trifile", i.e., your vehicle can equally be operated in air, on earth, in all its various manifestations and water. )

However, ACC also has its significant drawbacks:

- the complexity of the design;
- significant additional costs for the creation of this type of TLD;
- significant impact on the aerodynamics of the aircraft, causing problems with stability, balancing and reducing aerodynamic quality;
- The higher cost of ACC compared to wheeled chassis;
- High maintenance operating costs;
- Reduced service life of equipment and engines due to the harmful effects of dust formation initiated by ACC.

#### **Classification AACC on the scheme create an air cushion**

There are several schemes of ACC characterized by the way they form the AC:

1) AC formed by jet from nozzles (Fig.4), it is characterized by supplying air to the air-cushion chamber through the nozzles, which is a peripheral, closed-loop air-cushion device. The jet of air is supplied to the chamber through aligns of nozzles, which located around perimeter of the air-cushion chamber at an angles. Peripheral jet maintains overpressure by momentum "seal", which is a consequence of the equilibrium between the pressure differential across the jet and the

centrifugal forces in the curved jet airflow. Pressure in the cushion is maintained by this air curtain seal. Theoretically, this kind of scheme has minimal energy costs compared to other air-cushion schemes, but it requires long air ducts and complex devices to seal gaps between the cushion and ducts, which significantly increase the weight of airplane. With the existence of flexible skirt, the long and complex ducts through the entire structure has vanished.

2) AC formed by flow, it is different from the nozzle scheme in the way that the air is guided under the air-cushion dome, mainly from the bow toward the stern of the dome (tail section of a plane). The air-cushion zone is formed by elastic skirt, or rigid shields, fence (without front fence), sides and tail part. Flow from the nose area of the aircraft is beneficial to simplify the design of the air ducts, according to the expert; it is possible to reduce the overall drag of the air-cushion system. Fig.5 shows two forms of this scheme.

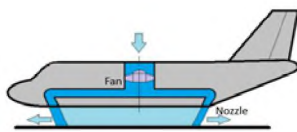
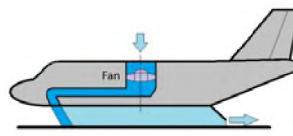
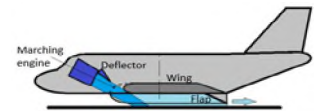

Fig.4. AC formed by jet from nozzles



*a*



*b*

Fig.5. AC formed by flow: *a*-using air curtain; *b*-jet from the engine

3) AC is formed by plenum chamber (Fig.6), it is characterized by supplying air through one or more holes located directly on the dome of the chassis, and differs from the way that peripheral jet uses to maintain overpressure, plenum chamber uses flow restriction. Such a scheme which is simpler and more convenient in layout.

4) AC is formed without chamber (Fig.7), it is also called air lubrication, in which air comes out from a pneumatic balloon through hundreds or thousands of openings under the base of a balloon, there is not clear definition to this kind of AC. But, there are several patents about its elastic skirts located in the bottom, which are used to reduce friction by supplying compressed air through a number of holes in the bottom of the bags. Based on this scheme, various trolleys are created to move heavy load.

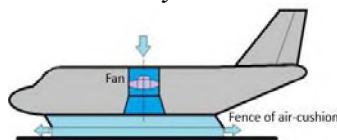

Fig.6 AC formed by plenum chamber

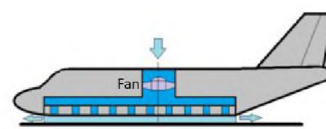

Fig.7 Air lubrication scheme

It should be noted that the boundaries of the distribution of AC are conditional. Ball screw can ensure the landing forces throughout the range of the "hardness" of the soil, however, the most efficient area of use are sites with a range of hardness –  $0.0 \leq \sigma_G \leq 0.6$  MPa.

In the range  $\sigma_G \leq 0.4-0.5$  MPa relative mass of the AC close to the ground "ground" the wheeled chassis, and at lower values of hardness of the soil relative mass of the ball screws may be even less than the mass of the wheeled chassis. This position is shown in Fig.8, where the axis of the abc is a parameter similar to the strength of the soil, and the ordinate - the relative weight of the chassis. The schedule of Fig.8 shows that when the hardness of the bearing surface of the soil decreases, the relative weight of the wheel chassis capable of operating the aircraft under these conditions increases significantly (red dependence), while the mass of the ballscrew remains approximately at the same level (blue dependence).

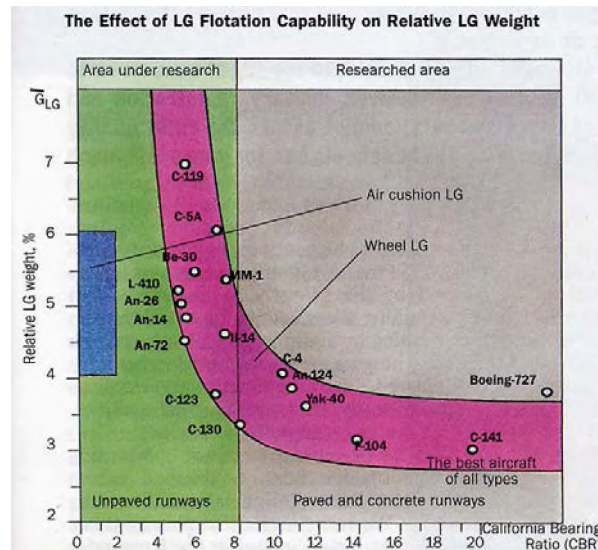

Fig.8. The dependence of the relative weight of the chassis on the bearing capacity of the airfield surface (according to the criterion-CBR.) Here the area orange is wheeled chassis, blue is ACC.

A critical analysis of the aircraft with the landing gear on an air cushion  
 Analysis of existing aircraft projects with air cushion landing gear allows to identify two groups of aircraft with ACC:

- Experimental aircraft, based on which the ballscrew is installed on conventional aircraft with a wheeled chassis, or seaplanes. This group includes the UT-2 with ball screws, EN-714 EN-14III, La-4 ball screw c, XC-8A Buffalo.

- Experimental aircraft in which the ballscrew was initially organically part of the structure when it was created. This group can be divided into three subgroups:

- The first subgroup airfoil and for aerodynamic, (PR. 903 “LUN”, PR. 904 “Eaglet”, CM-9, ELA-01, “Volga-2” and others),

- The second subgroup experimental aircraft designed to research and demonstrate new ideas (Superlight FV “Search” “Demonstrator”, Filimonov’s FV, AACC “Chirok”),

- The third subgroup is the AACC, created in accordance with the aviation rules for active entry into the commercial air transport market (AACC “Dingo”, “Froggy”, MIG-TA4, “032” and others).

It should be noted that the aircraft of the first group, mainly studied the principle of motion and made conclusions about the feasibility of this principle chassis. The experimental study of ACC was accompanied by a large number of problems related to the principle of formation of the AC, and the effectiveness of a particular node or unit. These problems were comprehended and solved. In most of the experimental aircraft of the first group, the performance of the hovercraft chassis was proved. The positive sides of the aircraft of the first group are obvious [13].

Let us now focus on those shortcomings that could serve as a brake for the introduction of the idea of ACC into practice. Almost all existing types of ACC are characterized mainly by the way of adaptation of the glider to the requirements of coordination with the ACC, the design of the elastic fence and are grouped around the design solutions of the three AACC. Let us consider these solutions as the most typical, typical for aircraft with ACC in their groups. As standard AACC we will take the design of three aircraft:

- AACC "Lake-4", (here are XC-8A, and "Chirok"),

- AACC An-14SH,
- AACC "Dingo", (MiG-TA-4, "Demonstrator", "Froggy").

#### **General conclusions on XC-8A.**

The main negative aspects of the Canadian project of the AACCXC-8A can be identified as follows:

- Non-compliance of the prototype AIRCRAFT requirements in coordination with the ACC, (primarily on transverse stability),
- Poor design of the elastic fence, captivating its external simplicity, but has a number of negative factors leading to a large amount of negative consequences,
- Lack of consideration of the impact of dust and moisture formation on the reliability of the units of systems and engines.

Additional consequences of the above shortcomings were:

- Low permeability of the fence on uneven,
- High costs for repairs and maintenance items of ACC, (repair shells, smartiest elements of elastic (flexible) air cushion guard (EACG) at low temperatures, the complexity of the adjustments and cleanings 40 channels air supply,
- Low reliability of elastic fence construction,
- An overall increase in structural mass of 2000 kg,
- Significant reduction in aerodynamic quality.

The General conclusions of bell's management on the practical use of XC-8A with ACC were negative. Nevertheless, the consequences of this work are still evident in various projects.

#### **General conclusions on theAn-14SH.**

The main disadvantages of the construction AACC An-14SH include:

- The unsuitability of the prototype aircraft for the installation of ACC,
- The complexity and low reliability of the elastic fence ACC An-14SH and the design as a whole,
- The neglect of the project AACC factor dust-moisture formation by the developers .

The problems revealed during the tests consistently led to the complication of ballscrew systems, to the raise in the complexity of maintenance and to a low reliability of the design. ACC An-14SH showed the estimated parameters of the cross, the resource shells of EACG was critically low. According to engineers, the repair of shells took a long time, access to many units was difficult, the selected material of the elastic fence was not sealed, and did not meet the requirements for flexible barriers of the AACC.

with AACC, unexperienced engineers faced an unexpectedly high harmful effect of dust, which was initiated by the air cushion. The pressure reduction in the RP chambers led to a corresponding (compared to the HS-8A) decrease in the transverse and longitudinal stability of the aircraft on the take-off and landing run. Open shell cones were easily torn when hitting the bushes and reinforcing bars.

The An-14SH experimental aircraft was actually an experimental laboratory. However, the opinion of pilots about the possibilities AACC since the testing An-14SH was high.

#### **General conclusions on AACC "Dingo"**

There are criticisms of the aircraft "Dingo", which include:

- Low weight return,
- Relatively low aerodynamic quality,
- Manageability issues

The relative weight of the empty aircraft "Dingo" is more than a similar indicator of dry-track wheeled vehicles, but less than that of amphibious seaplanes. Do not forget that in the aircraft "Dingo", in addition to the injection complex, implemented additional structural safety measures – separators to protect both engines from dirt, regular anti-icing system, sealing airframe compartments, which was a "fee" for reliable operation in extreme conditions.

The aerodynamic quality of the aircraft "Dingo" ( $C_L/C_D=11$ ) for aircraft of this category (even land) should be recognized as good.

The most important problem in the development AACC "Dingo" was the solution for the cleaning of the pneumatic cylinders. According to estimated calculations, in the retracted pneumatic cylinders aerodynamic quality of the aircraft is increased by 0.5-0.7. This leads to an increase in the range by 70 km, which is equivalent to an increase in the fuel supply by 42 kg.

### Design features ACC aircraft "Dingo".

The chassis on the air cushion of the Dingo aircraft was created in accordance with the principle of "early coordination", the essence of which was that the linkage of the main principle design and layout decisions on ACC with the Aero-hydrodynamic layout of the aircraft was carried out at the stage of concept formation. The Dingo is one of the first AIRCRAFT with ACC created in accordance with the aviation rules AP-23 and FAR-23.

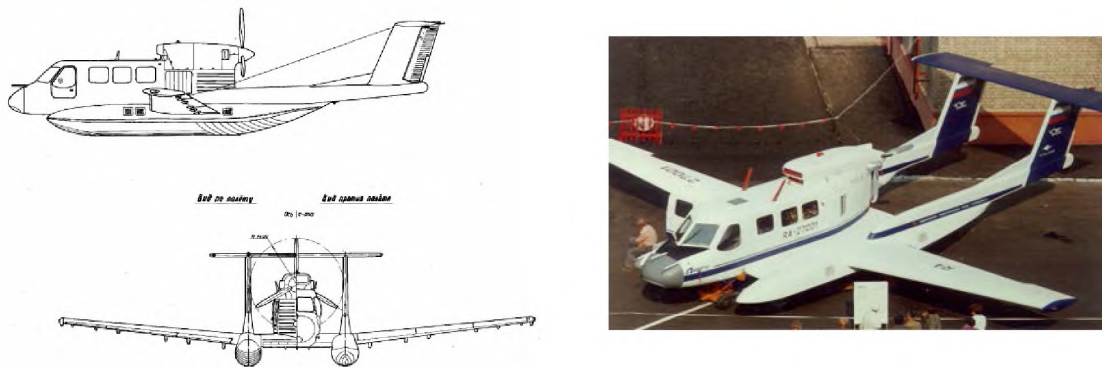

Fig.9. AACC "Dingo"

The Dingo aircraft is designed according to a two-girder scheme with a low wing and a U-shaped tail. The main power element of the aircraft is the center section, which is attached to all the units of the airframe: wing consoles, tail beams, fuselage and airballs are not removed, Fig.10. Pneumatic cylinders was a combination of solid tires with the redan's system and protective wear-resistant layer of rubber soles and a built-in camera. The tire of the air balloon was made taking into account the technology of ThKB PK. In the upper tail of the fuselage we have the main turboprop engine RT6A-65V with a pushing propeller, a diameter of 2.82 m.

In the lower compartment is a turbofan unit TVA-200, 250 HP designed to create an air cushion. The center section is limited in scope by pneumatic cylinders, performing the role of the side fences of the air cushion, support elements, shock absorbers, effectively absorbing vertical impact, pneumatic landing and floats during swimming. The air cushion is created under the center section by pumping air from the TVA-200 there with an overpressure of about 3.50 kPa, and is limited on the sides by airballs, and in front and behind by hinged elastic shields, retracted in flight to the center section, Fig.10

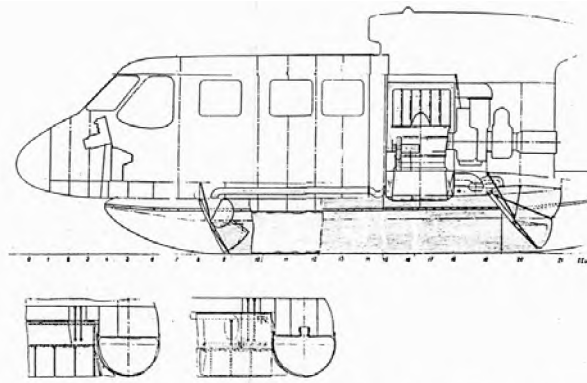

Fig.10. The layout of ballscrews "Dingo"

The center wing and consoles have sealed bulkheads that ensure the aircraft's navigation in case of damage of the air balloons, as well as any two adjacent compartments of the airframe structure. The layout of the aircraft protects the propeller from damage and contact with water and bushes. The engine air intakes are placed in the cleanest zone. In addition, all air intakes have special separators that protect the engines from foreign objects, dust, sand, dirt and moisture entering the air path.

Pneumatic ballony the chassis of the Dingo allows you to achieve;

- good hydrodynamic performance;
- good permeability, (low pressure in p/cylinder is 4 KPa.);
- good stability in all driving modes, both with the operating VP, and afloat;
- safe and efficient braking on all types of surface;
- parking on any ground, including swampy, deep snow, etc.;
- high resource shells ( much more than An14SH and CX-8A);
- high intensity chassis and efficient damping of the landing impact.

The most important condition for the construction of "Dingo" was the requirement of reliable operation in conditions of high dust moisture formation and low temperatures. To this end, all the main units of the aircraft are protected from dust and moisture, both engines, main and lift have built-in air intakes specially designed separators with heated inlet lips. The air intakes are placed in the cleanest zone. Fuselage cabin during movement on a runway inflates a small excess pressure, prevent-conductive dust in the salon. All sensors-receivers of static and full pressure are blown after take - off and have anti-icing heating. The aircraft is equipped with a mechanization of the wing, capable of operating in conditions of freezing of moisture and sand. Instead of the pre-wing, the wing has a special modified profile, ensuring the achievement of large angles of attack. The interior and windshields are heated with warm air, in addition, the windshields are cleaned with alcohol and wipers brushes (according to polar pilots, when flying in the tundra at low altitude, a green mush of midges flows through the windshield and alcohol cleaning is necessary for landing).

On the recommendation of technicians-operators of aircraft in the Northern regions of Russia, the constructors at Dingo abandoned the anti-icing system of the Goodrich type as unreliable, and used the usual thermal heating system of the sock. For the purpose of safe operation of "Dingo" in the Northern areas it is excluded hydraulic drive. Most of the ACC systems are duplicated, as well as aircraft control systems. Particular attention was paid to the onboard radio navigation and communication equipment, which allows the aircraft to go to the site even in bad weather, "see" it with the help of a locator and make landings. In order to ensure safety during a rough landing, each air balloon has two built-in safety valves that relieve excess

pressure during a vertical impact and “cut” the overload to the normalized level. For the same purpose, the left and right cylinders are looped, i.e. connected by a pressure equalizing nozzle.

The lodgment part of the center section is below the center section and is shaped like a ski with a raised toe, which ensures a safe emergency landing in case of damaged cylinder tires.

### 3. CONCLUSIONS

The aircraft "Dingo" is the FV. although it has its disadvantage that are solvable by raising enough funding and fixing the main problems, we can say that it is one of the most challenging and revolutionary landing gear ever made regarding its capacity to take off and land on any surface since not all the country in the world can afford necessary infrastructures for take off and landing, which sets out the principles that it may become the rule for future heavier, and hence more rational and cost-effective aircraft no airfield-based.

### Reference

- [1]. Y Liang, Theory & Design of Air Cushion Craft, [M], Elsevier, Oxford, 2005.
- [2]. David J. Perez, William A. Benner, Development of An Air Cushion Landing System, [R], AIAA 5th Aircraft Design, Flight Test and Operations Meeting, August 1973.
- [3]. Demeshko G.F., Designing of Amphibious ships on an air cushion, [M], Department of Shipbuilding and Aircraft Engineering, 1992. (In Russian)
- [4]. Kulbida V. E., Morozov V. P., Transport efficiency of non-aerodrome based aircraft, Moscow. “NIA-Priroda”. 1999. 92p. (In Russian)
- [5]. Features of designs of air amphibians (definitions, classification, history of development, design features), Works of NSTU named R. E. Alekseev, 2015. 75p. (In Russian)

### Authors



Victor Morozov



Gabriel Andriamanantena



## TEACHING OF RUSSIAN LANGUAGE IN THE FRAMEWORK OF SANDWICH PROJECT BETWEEN NATIONAL AEROSPACE UNIVERSITY “KHAİ” AND NANJING UNIVERSITY OF AERONAUTICS AND ASTRONAUTICS

**Olena Litvinova, Alina Matskevich, Natalya Sytnyk, Dmytro Toporets**

National Aerospace University KhAI, Ukraine,  
61070, Kharkiv, 17 Chkalova street  
e-mail: dean10@khai.edu

**Key words:** Aerospace Engineering, sandwich project, methodological guidelines, language training, program framework.

**Abstract.** *The objective of this paper is to share the experience of sandwich project within the framework of bilateral agreement between National Aerospace University "KhAI" and Nanjing University of Aeronautics and Astronautics. The measures were provided with attention paid to the specific group of graduates as prospective and aspiring aerospace engineers and related experts.*

### 1. INTRODUCTION

Long-lasting friendly ties exist between National Aerospace University "KhAI" (Ukraine) and Nanjing University of Aeronautics and Astronautics (China). In the distant 50s of the 20th century KhAI specialists assisted in the creation of the Nanjing Aviation Institute (the former name of the university), which was established on the basis of aviation technical school. In those times NUAA had only four faculties, and the number of students did not exceed 3000 people. Nowadays it is one of the largest universities in China with more than 20 thousand students. In 2008 NUAA became a member of the research universities of the People's Republic of China.

### 2. MAIN PART

In 2007, an agreement was signed between universities to open joint education in the framework of the so-called sandwich project. In accordance with the agreement between NUAA and KhAI organize training of bachelors and masters among the citizens of the People's Republic of China on curricula of majors, the list of which is approved by the Cabinet of Ministers of Ukraine. Accepted students, recruited by NUAA according to the existing rules of state recruitment in China, receive the right to study at both universities at once.



Fig. 1. Chinese Students with KhAI teacher of Russian Language at NUAU



Fig. 2. NUAU representatives at KhAI

The total period of study is 6.5 years. Training is planned and conducted by both parties. The first two years of the bachelor's program students are trained in China. Part of the academic subjects, including Russian language, and special educational lectures are read by the teachers of KhAI University. The next two years students are trained in Ukraine. Master's program is divided into two stages: the first stage lasts 1.5 years at KhAI (during this period all requirements of the Ministry of Education of Ukraine are fulfilled), the second stage lasts one year in China (during this period all the requirements of the NUAU are fulfilled).

Students who successfully complete their studies receive relevant degrees from both universities.



Fig. 3. Chinese Graduates with KhAI degrees

The training of the Russian language in the framework of this project is a combination of traditional and innovative approaches to learning that takes into account the specifics of learning outside the language environment, national, mental and psychological characteristics, while using the basic knowledge of students in the field of language and culture that they acquired at home. The total class hours for the Russian language in each semester account for 128 hours. Despite the existing differences in methodological approaches, Ukrainian and Chinese colleagues have managed to develop uniform training requirements and methodological guidelines. The evaluation system in China is 100 points, which, in our opinion, allows us to evaluate the knowledge gained by the students. Control in the form of written works is carried out at the end of each semester. As a result of the semester control a student either continues their studies in this group or drops out. The number of students in the end is reduced to 15-17 candidates who really can continue to study at KhAI University.

Experience has shown that after the second semester, the students demonstrate receptive language skills, i.e. the ability to read and translate, answer questions on this text, and perform grammar exercises. Naturally, the forms of work at the next stage become more complicated and after the third semester the students are already able to independently write their own statement at the micro-text level, using not only simple but also complex sentences. The goal of the tasks at this stage is to improve the skills and abilities of the situational use of the learned linguistic and speech models.

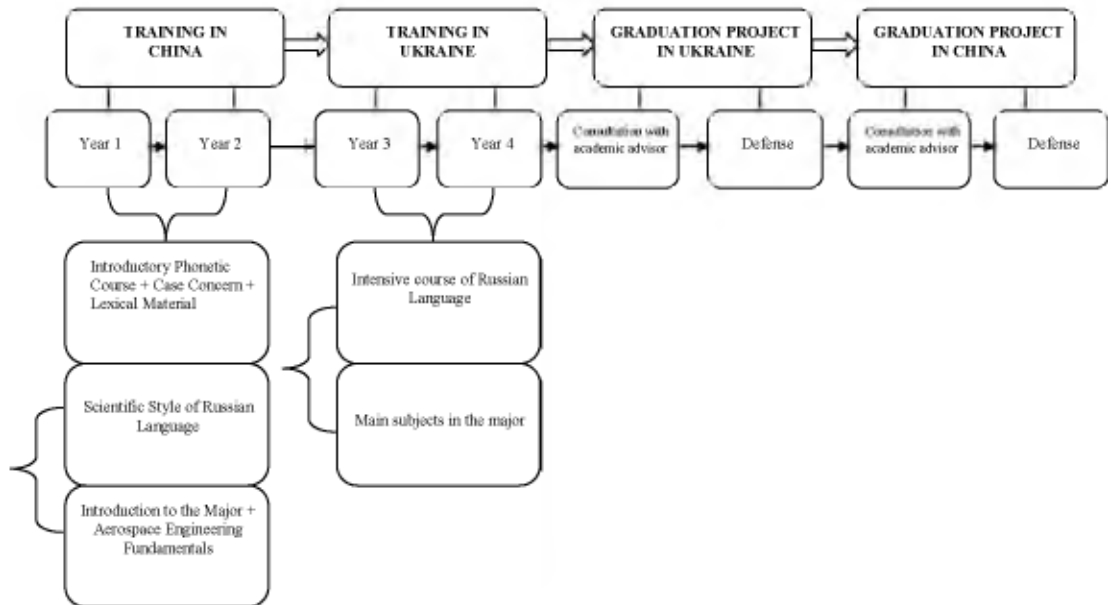

Fig. 4. Program Framework for teaching Russian language to Chinese students



Fig. 5. Chinese students trained at KhAI

Particular attention shall be given to the development of lessons on teaching the scientific style of speech on the basis of the adapted material of lectures by subject teachers. This is based on familiarizing and studying the reading of the text, various types of work that are aimed at developing skills of professional speech in the field of educational and professional communication. It should be noted that some tasks may cause difficulties for students, but their expediency is justified by the fact that teachers begin to read technical lectures in Russian in the fourth semester, after which students continue their education in Ukraine.



Fig. 6. Chinese students with teacher of Russian Language at KhAI

### 3. CONCLUSIONS

To sum up, it should be noted that participation in this project is not only interesting, but also fruitful. Currently KhAI teachers are working on creating a textbook on the scientific style of speech for Chinese students who are trained within the framework of this sandwich project.

#### Authors



Olena Litvinova



Alina Matskevich



Natalya Sytnyk



Dmytro Toporets

## CIVIL AIRPLANE RATIONAL DESIGNING ON THE BASE OF AERODYNAMIC REQUIREMENTS

Clifton Read<sup>1</sup>, Dmytro V. Tiniakov<sup>2</sup>

1 – Executive Wisdom Consulting Group, Brisbane, Australia

e-mail: [cliftonread@y7mail.com](mailto:cliftonread@y7mail.com)

2 – Nanjing University of Aeronautics and Astronautics

College of Civil Aviation

Jiangjun Ave., 29

211100, Nanjing, China

e-mail: [tinyakov\\_dm@mail.ru](mailto:tinyakov_dm@mail.ru)

**Key words:** Aircraft design, training methodology, aerodynamic requirements.

**Abstract.** *The paper contents some recommendation for the adjusting of training methods of an aircraft design, which based on the aerodynamic requirements. The wide using of different examples with real structural solutions promote to the concentration of the training material and increasing of student audience attention. The real-life engineering has many samples about how aerodynamic requirements influence to the aircraft view. Some of engineering variants, used by designer for new airplane can decrease of aerodynamic performance of an airplane. If they were applied without correct analysis of possible influences on its aerodynamic performance, it will decrease lift-to-drag ratio, etc. This influence requires additional expansive aerodynamic researches, but if a designer will base on the previous experience (statistical data), it is possible to find more rational solution, which compensates the negative influence in general or decreases the cost for additional research. So, to adjust the training process and improve the students designing experience, it is needed to add in learning process examples of previous airplanes structures with comments about their influence on the aerodynamic performance.*

### 1. INTRODUCTION

The problems that are present before the lecturer of courses, which relate with designing, testing, etc. of aircraft, were detail describe in [1]. One of the specific for airplane parameters selection is providing best aerodynamic performance with keeping all another their specifics (like take-off weight, strength, manufacturability, etc.) at highest possible level or in certain limits. Aircraft are very sensitive to the aerodynamic loads. From the one side the lift must be higher, from another side the drag must be smaller. All of these collisions and specific can be simplified or partially solved at the preliminary design stage.

So, for students it will be useful for understanding to know some principles of an airplane designing that provide certain aerodynamic performance (like lift-to-drag ratio, etc.)

Also, the analysis of these examples will be interesting for engineers, which tasks relate with designing for understanding solutions that present at old aircraft with high operational efficiency, which was proofed by time.

## 2. EXAMPLES AND THEY ANALYSIS

As it is known, the structure should provide the certain values of factors drag coefficient  $C_D$  and lift coefficient  $C_L$ , lift-to-drag ratio  $K$ . That is why the surface of the units must have the least roughness, doesn't change its original shape under loading and has no buckles. The fasteners, which have projection on the surfaces blown by air stream should not project or sink down concerning external contours of units.

The units and devices used only at certain modes of flight (take-off and landing), in non-working condition should influence as little as possible  $C_D$  and  $C_L$ . The units of aircraft, flying at high speeds, should be pressurized for preventing spillover of air owing to non-tightness which breaks smoothness of a stream and promotes its separation. The various access doors and hatches necessary for checking and servicing should be placed in zones of increased pressure, but in no way in zones of rarefaction. The members, which do not carry aerodynamic load should be removed from the surfaces flown by air stream, and owing to impossibility, they must be closed by fairings.

Requirement of aerodynamic perfection consists in a choice of external shapes and relative position of aircraft units, which allow to obtain the specified characteristics with minimum power expenses (fuel). These tasks are solved during aerodynamic and general designing of the airplane. The task of the designers, developing a structure directly, consists in providing required quality of external surfaces, i.e. real design solutions should not substantially increase a parameter  $C_D \times S_w$  and reduce factor  $C_L$ .

The requirements of aerodynamic perfection are next:

- the coefficient of lift force of  $C_L$  must be as possible higher;
- the coefficient of drag of  $C_D$  must be as possible smaller;
- the lift-to-drag ratio must be as possible higher;
- the location changes of the focus  $\Delta F_x$  at the modes of flight change must be as possible minimum;

To satisfy to the aerodynamics perfections requirements it is possible by the rational choice of external shapes and relative aircraft unit's location.

There are some examples that can be used in training the course "Aircraft Design".

### *Example 1. Aspect ratio influence*

Dependences of lift coefficient on the angle of attack of  $C_L = f(\alpha)$  is shown in Fig. 1 [1,2,3,4].

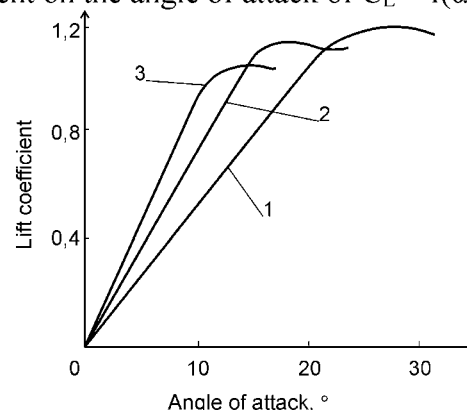

Fig. 1. Dependence of  $C_L$  from the attack angle for various values of the aspect ratio: 1 – aspect ratio 2.5; 2 – aspect ratio 4; 3 – aspect ratio 10

As it is seen, than aspect ratio higher than  $C_L$  higher for the same angle of attack. But, also it is shown that with growing of the aspect ratio the critical attack angle decreases.

If the Fig. 1 shows two opposite influence of the aspect ratio to  $C_L$ , than from Fig. 2 [1,2,3,4], which shows the dependence of  $C_L$  from  $C_D$  (polar graph), clear seen, that lift-to-drag ratio grows at high degree with the aspect ratio growing.

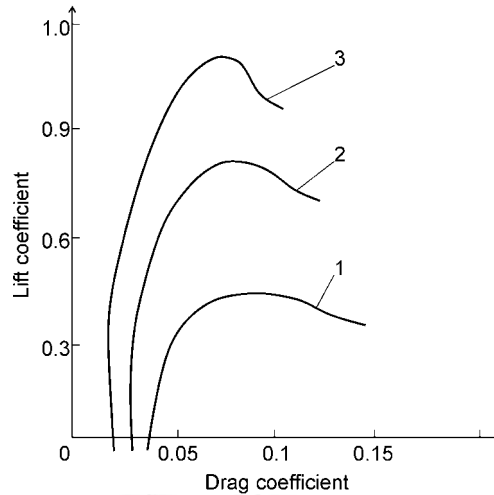

Fig. 2. Dependence of  $C_L$  from  $C_D$  for various values of the aspect ratio:  
1 – aspect ratio 2.5; 2 – aspect ratio 4; 3 – aspect ratio 10

From here it is clear understand why gliders (Fig. 3) have so high value of the aspect ratio (maximum is near 50). This way proposes for a designer good ability for the lift increasing and drag decreasing.



Fig. 3. Two seats glider has aspect ratio 20

But, if the specific load on a wing will grow (for airplanes with powerplant), wings with high aspect ratio have negative features – low stiffness, that create conditions for its weight growing. So, for the cargo category aircraft (Figure 4) there is limit for the aspect ratio – 12. For example new Boeing company project B777X. It has folded wing (Figure 4). Why? Because for the providing best aerodynamic performance designers of the Boeing company increased wing span to 71.8 meters, that provides aspect ratio 11.04. But for the good taxing at usually airports they proposed complex, very expansive structural solution – folded wing, that provide decreasing of the wing span to 64.8 meters.



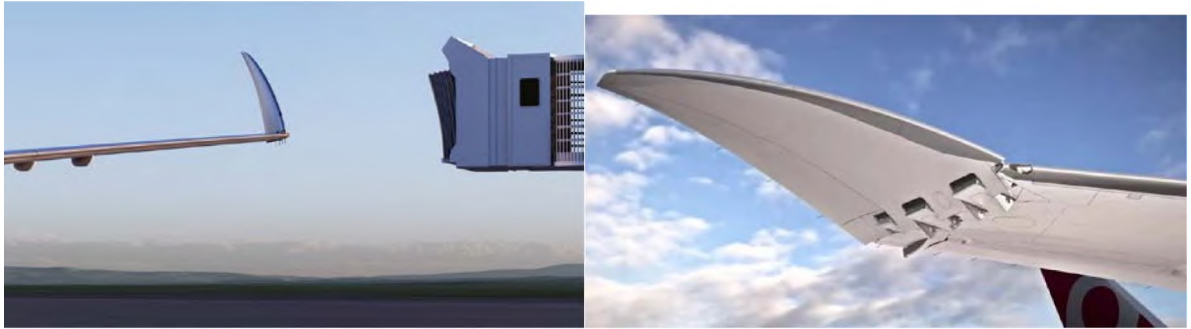

Fig. 4. Boeing B777X and its folded wing tip [5,6,7]

It is seen that aviation engineers try use different ways for the aspect ratio increasing.

**Example 2. Swept angle influence**

The biggest part of aviation specialist know that low speed airplanes have straight wing with swept angle about  $10^\circ$ , airplanes with subsonic flying speed have swept angle wing with angle smaller then  $40^\circ$  and supersonic airplanes usually have delta-wing with swept angle near  $70^\circ$ .

The explanation of this specific is very easy – then the flying speed is near sonic speed, than higher wave drag, at the supersonic airplanes, the wave crisis is present. The image of what happen near the sonic speed is present in Fig. 5 [1,2,3,4].

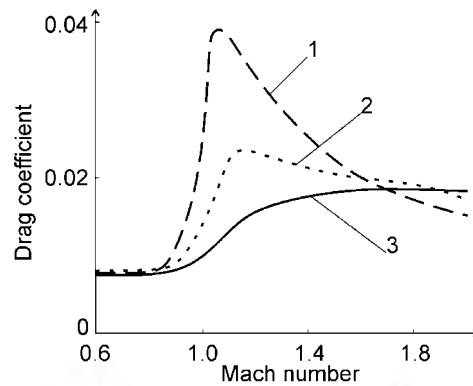

Fig. 5. Dependence of  $C_D$  from Mach number for different values of swept angle:  
 1 – elliptical wing with swept angle  $0^\circ$ ; 2 – delta wing with swept angle  $60^\circ$ ;  
 3 – swept wing with angle  $60^\circ$ .

In Fig. 6 [1,2,3,4], the dependences of the lift coefficient from the swept angle are present

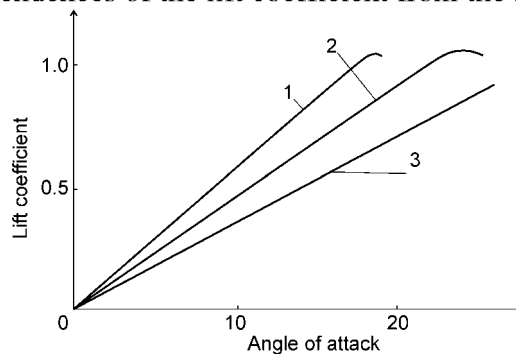

Fig. 6. Dependence of  $C_L$  from the angle of attack for different values of the swept angle for the wing with aspect ratio 2.5:1 – swept angle  $0^\circ$ ; 2 – swept angle  $45^\circ$ ; 3 – swept angle  $60^\circ$

As it seen from these Figures with the growing of the Mach number the  $C_D$  grows to. For its decreasing, a designer must increase the swept angle. But, automatically in this case will decrease and  $C_L$ .

As result at the supersonic speed,  $C_D$  is higher than at subsonic speed and  $C_L$  is smaller, so total lift-to-drag ratio is low (See Fig. 7 [1,2,3,4]).

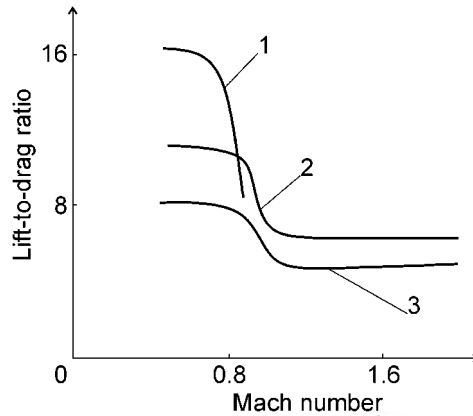

Fig. 7. Dependences of the lift-to-drag ratio from the Mach number:  
1 – swept angle 10°; 2 – swept angle 60°; 3 – swept angle 85°

This event has name Wave crisis. It is start from transonic speeds and will increase effect with higher speeds.

But, as it is shown in Figure 7, the low swept angle cannot provide any lift-to-drag ratio at the transonic and higher speeds. So, designers must use this way (increasing swept angle), because only it can provide smallest decreasing of the lift-to-drag ratio.

As examples we can take DC-3 – famous airplane before World WAR II, B737 – more popular passenger airplane in the modern time and Concord – one of the supersonic passenger airplane [5,6,7].

DC-3 has 11°50` swept angle at ¼ chord line, B737 – 25° at ¼ chord line, Concord – from 60° till 80° at leader edge. As it seen that with the speed growing and the wing swept angle grows too.

Additional way to provide maximum aerodynamic performance is using of the wing with variable swept angle. But, this way add additional structural weight, that is have negative affect to the economic efficiency of civil commercial airplanes. So, this structural solution is seen at military supersonic aircraft (Figure 8) [6].

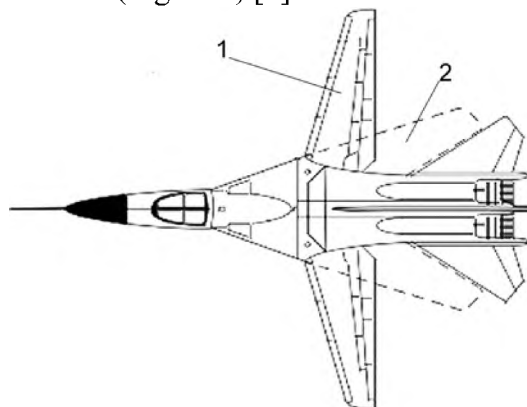

Fig. 8. Supersonic fighter with the variable swept angle wing:  
1 – subsonic configuration; 2 – supersonic configuration

**Example 3. Shape and relative thickness of airfoil**

This is parameter, which influence not only on aerodynamic performance, but on structure, strength, operational, etc. features. But, here it will be explain only its aerodynamic effect.

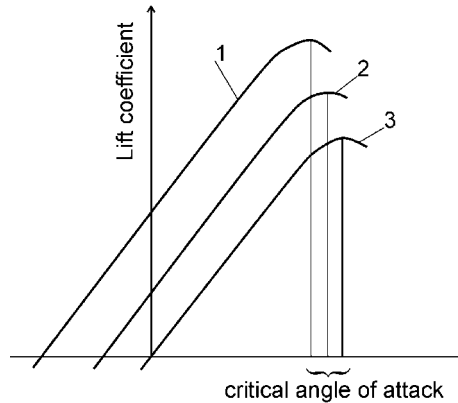

Fig. 9. Influence of airfoil shapes on the lift coefficient and critical angle of attack: 1 is an airfoil of large curvature; 2 is an airfoil of small curvature; 3 is a symmetric airfoil

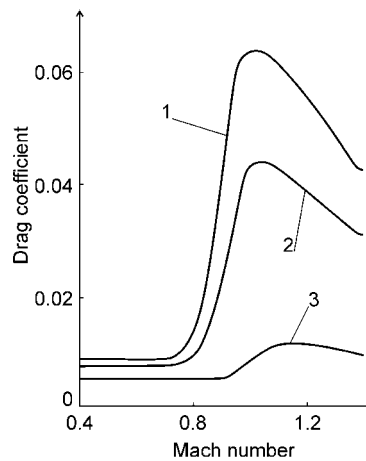

Fig. 9. Influence of airfoil thickness on the drag coefficient and critical Mach number: 1 – relative thickness 10%; 2 – relative thickness 8%; 3 – relative thickness 4%

The airfoil shape has substantial influence on lift properties of airfoil. What more curvature of airfoil, the higher lift coefficient  $C_L$  (Fig. 9) [1,2,3,4]. The critical angle of attack decreases at the same time.

Reduction of relative thickness gives the reduction of the drag coefficient  $C_D$ , and growth of  $M_{cr}$  (Fig. 10) [1,2,3,4]. It resulted in the wide use of wings with thine airfoils on supersonic aircraft.

We can take same airplanes for example: DC-3 has airfoil NACA 2215 with maximum specific thickness 15 %, Boeing B737 – BAC 449 with specific thickness 15.4%, Concorde has only 3% specific thickness [5,6,7].

**3. CONCLUSIONS**

In proposed examples students can see designer’s means about improving of aerodynamic performance. Different structural solutions of aviation companies show that engineers take a final decision not only under effect of the direct task, but also under influence

all other factors – like manufacturing specifics, traditions of the designers school, materials availability, etc.

But, all of these solutions have only one task to improve aerodynamic quality of an airplane. Efficiency of them depends from different factors and each company have own way. So, for students it will useful to learn all wide range of structural solutions for providing certain aerodynamic performance.

## REFERENCES

- [1]. Barnes W. McCormick, Aerodynamics, Aeronautics, and Plight Mechanics, Wiley, New York, 1979.
- [2]. Holjavko V. Aerodynamic Characteristics of Aircraft. Kharkov: Hark. aviac. in-t, 1998.
- [3]. Corning, Gerald. Supersonic and Subsonic Airplane Design. Published by the author. 1960.
- [4]. John D. Anderson, Jr., A History of Aerodynamics and Its Impact on Flying Machines, Cambridge University Press, New York, 1997.
- [5]. Glauert, H. Elements of Aerofoil and Airscrew Theory. 2nd edition; Cambridge University Press; 1983.
- [6]. 777X Wing Tips [Electronic resource].  
<https://cn.bing.com/images/search?q=777X+Wing+Tips>
- [7]. Уголок неба. Большая Авиационная энциклопедия [Electronic resource].  
[www.airwar.ru/index.html](http://www.airwar.ru/index.html)
- [8]. Wikipedia [Electronic resource]. <https://www.wikipedia.org/>

## Authors



Clifton READ



Dmytro V. Tiniakov

## VIRTUAL REALITY AS AN ONGOING CHALLENGE FOR AVIATION INDUSTRY

Fares Elsherbiny<sup>1</sup>, Oleksiy Chernykh<sup>2</sup>

1 – University of Politehnica, Bucharest, Romania.  
Faculty of Aerospace Engineering  
Str. Pajurei nr.12  
Bucharest, Romania  
e-mail: faris.elsherbiny.1@gmail.com

2 – Nanjing University of Aeronautics and Astronautics  
College of Civil Aviation  
29 Jiangjun Avenue  
Nanjing, 211106, Jiangsu, China  
e-mail: alex@nuaa.edu.cn

**Key words:** virtual reality, civil aviation, flight training, flight simulator, equipment, device, interactive, haptic feedback, human biology.

**Abstract.** *Virtual reality is an ever-growing mechanism of entertainment currently expanding and being used more and more by average everyday technology enthusiasts. However, engineers or more specifically aerospace engineers have been using this technology in aviation for a long time. This article briefly speaks about the advantages, disadvantages, the major players and technologies being used. Both commonly utilized, such as cockpit flight simulators, and recently newly introduced, such as Google Glass, Aero Glass, HoloLens, virtual reality equipment has been mentioned. The implementation of virtual reality in flight training has obviously been controlled by safety regulations among which FAA's 14 CFR 60 has been noted. The article also raises concerns on interaction between a human and virtual reality which fact forces authors to conclude with challenging questions of its present utilization limitations.*

### 1. INTRODUCTION

Augmented reality has been used in engineering in various applications, across multiple minor and major applications for different technological support, aid, research and development. In modern day times however, a new type of virtual reality has been developed and grown much ahead. Being the concept of virtual reality, it is an interactive computer-generated reality or experience which takes place in a simulated environment using sensory or haptic feedback of a visual and auditory stimulus. Modern day concept of virtual reality strongly stands on the usage of the entertainment industry, however engineers know no such statement as “an idea farfetched”. In recent years, engineers and companies alike have been developing and further growing the concept of using virtual reality across multiple platforms, departments and applications in the aviation industry which further fueled the process of modern-day usage of virtual reality in designing newer programs, systems and complete training routines based on the growing technology.

## 2. COCKPIT SIMULATORS

The most commonly known and perhaps the one most often used is definitely the use of cockpit simulators to train pilots for various flight licenses. Used mostly by the popular and famous international flight schools, flight simulators use an input designed for a very specific user base being beginner level flyers and aviators. Flight simulators are such a success that with the current investment being made in the field, the growth and yield return to manufacturers will be considered quite massive since the investment capital of both human resources, time and finances ranges in such an extent that the manufacturers are consolidating a double-digit exponential growth and vertical integration of training. The CAE Aviation Academy estimates 255,000 new airline pilots between 2017 and 2027 will be trained at a rate of 70 per day and assisting another 180,000 first officers blossoming to captains. The statistics made by the Canadian company CAE Inc. would not benefit them in any certain means if they are false since the company itself is definitely the great white shark of the industry with 70% of the market share owned and \$2.8 billion in annual revenue made only in manufacturing and training [1]. Regardless of such a business presence, companies like Thales Training & Simulation's and L3 commercial training solutions ltd. continue to viciously fight in the market over the remaining percentages and with CAE Inc. Flight simulators being considered some of the elaborate and complex virtual reality systems at the current time since they have the most responsive feedback from the apparatus towards the input of the user. This is implied using an artificially intelligent computer control system that control mechanically operating flexible motion simulators in response to the users input towards the haptic and visual projection on a screen. When the statistic schematics of how the handling procedures and trainings are broken down into multiple and various parts, the striking major observation is that skill transfer based on training on a simulator and leading to handling an actual aircraft are difficult to make, particularly where motion cues are concerned.



Fig.1. Super Jet international flight simulator FFS 1 installed by L3 CTS.

The major setback being that the aviation industry within itself tends to bias towards certain aircrafts, this projects on the subjective view of flight simulators particularly in pilots who are usually never used to giving an objective real assessment of situations nevertheless equipment or systems. The major belief to recent times was that the 6-degree-of-freedom (DOF) motion-based simulation got pilots to the closest proximity to flight control operations and aircraft responses to control inputs and external forces and gave a better training outcome for students than non-motion-based simulation. This was later referred to in handling manuals as the "handling fidelity", which in modern day became assessed by test flight standards of the likes of the numerical Cooper-Harper rating scale for handling qualities. Recent study shows that this specific factor, teaches students to get used to vibrations and unusual behavior of aircraft components and input commands which is majorly due to the higher financial investment in vibration or dynamic seats within flight simulators can be equally as effective in the delivery of training as large and expensive 6-DOF FFS (full flight simulators) devices [2].

### **3 . SAFETY REGULATIONS**

The fact that the world's major air traffic safety service providers, namely the United States Federal Aviation Administration (FAA) and European Aviation Safety Agency (EASA) offer different levels of licensing for differently qualified producers has created an intense business for manufacturers, which has in turn created a high quality finished product that is now regulated by these institutions. This is done using specific laws and regulation such as the FAA basic ATD (BATD) 14 CFR 60 used to provide the adequate training platform and design for both the procedural and operational performances tasks specific to the ground ops and flight training for private pilots, commercial pilots, air transport pilots, flight instructors and instrument ratings [3]. There is a bottom less pit of a list that involves the different levels of the trainings and licensing offered by each of the providers which is to be explained separately.

### **4. VERTICAL FLIGHT SIMULATOR**

Even though virtual reality has been implemented in depth and defined appropriately by multiple institutes, this was only a meagre introduction of virtual reality into aviation. The further expansion of which was dwelled into deeper by none other than NASA and its patented state-of-the-art vertical flight simulator (VMS). VMS is the world's largest and most powerful flight simulator located at the NASA Ames research center, to the south of San Francisco, CA, USA. Its simulation is that of a "catapult" or, in layman terms, a simple throw motion with an indent curve of 60 ft (+/- 30 ft) of vertical movement (heave). The motion of the heave itself uses a horizontal support beam of a 40 ft rail allowing a 20 ft space for movement. A classical 6-degree-of-freedom hexapod platform is mounted on top of the 40 ft beam, and a replaceable cabin mounted on the platform. The point of such complexity would be that using these interchangeable cabins allows us to simulate multiple air vehicles ranging from blimps, commercial and military aircraft to the Space Shuttle [4].

### **5. AERO GLASS**

The band wagon continues to haul in and capture the industry by storm since airlines and military users have tested juvenile virtual reality systems such as Google Glass in the case of

civilian flyers. Although Google Glass has been shelved, it set a positive footnote with companies of the likes of Japan Airlines, TAE Aerospace and Air New Zealand. To use virtual reality in their new next generation training currently conducted for engine mechanics and flight crew. Currently replacing blueprints/printouts and design layouts of cockpits and engine components with a descriptive immersive user interface that allows for easier usage and quicker access to data and parts that are to be changed, repaired or to keep maintained. An Aero Glass, which was a tool proposed for such training found its way to pilots. The Aero Glass has a headset that pilots can wear and view cockpit control information like altimeter readings, fuel pressure, heading and oil temperature within a display that sits in the glass portion of the headset. Aero Glass made headlines in October 2016 when Airbus BizLab selected their technology as one to help become transformed into a business proposition. The head-worn display concept has also received funding from the European Union's Horizon 2020 research and innovation program [5].

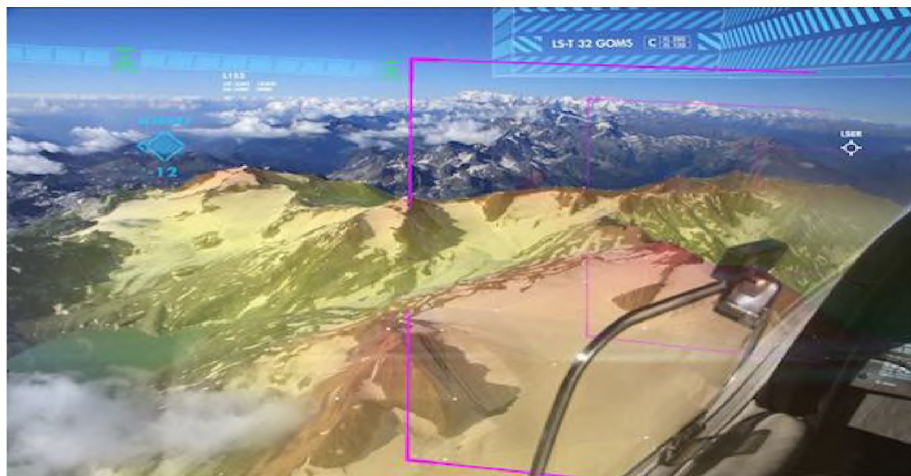

Fig.2. Screenshot of images produced by an Aero Glass.

## 6. HOLOLENS

These same high-end investors continue to meddle with virtual reality specifically using HoloLens. Microsoft describes its HoloLens headset as a “fully self-contained holographic computer” with an optical system that works with advanced sensors and a holographic processing unit (HPU). The HPU is a TSMC-fabricated 28 nm co-processor that has 24 silica product-based cores making use of around 65 million logic gates, 8 MB of SRAM, and an additional layer of 1 GB of low-power DDR3 RAM. That RAM is separate to the 1 GB that's available for the Intel Atom Cherry Trail processor, and the HPU itself can handle around a trillion calculations per second [5].



Fig.3. Final concept design of the Microsoft HoloLens.



## **7. OTHER WORK CURRENTLY BEING DEVELOPED**

Air New Zealand, in collaboration with the IT service-provider Dimension Data, is to beta-test the use of HoloLens for cabin crew personnel. The airline envisions a future where flight attendants wearing a HoloLens headset can display passenger information on the headset such as flight details, time since last served and even the emotional state of a passenger. Virtual reality continued to be used in a completely different rather than just pilots and engineers. Aircraft design companies continue to use virtual reality in material placement and 3-dimensional designs of newer aircrafts paving the way to a new path of completely different horizons and scope for preliminary aircraft design for aircrafts since it provides an all-important opportunity to “pre-build” and test aircrafts that possess relatively new designs or wilder new concepts in order to test them before investing further finances and resources to ensure a finer finished final aircraft. Perhaps, the most rudimental of the most known uses of virtual reality is training unmanned air vehicles and the design of human artificial intelligence interface to optimize usage of long-distance remote-control unmanned air vehicles. It has become a very strong base for military drones which has expedited rapidly the development of the systems for leisure unmanned air vehicles as well [5].

## **8. DISADVANTAGES OF VIRTUAL REALITY AND WHY WE SHOULD BE CAREFUL USING IT IN AVIATION**

However beneficial it may seem at the current time, virtual reality in aviation must progress further. A major bane would be the buffer time in human users that usually takes time to return to being fully able to operate and work more popular classic equipment. There is no solution at the current time for this issue for evading this buffer time since human biology is not fully evolved or at least comfortable with using immersive reality. This buffer time fools the human nervous system causing vital senses in the industry such as vision, auditory and touch to hinder due to either a delay in responses or confused reactions to reality and physically present equipment. This error is not one to omit. The aviation industry is the only type of transport that operates at minimal failure and accident rate, hence this error is not one companies are willing to deal with. Regardless to mention that the industry itself moves at an incredibly cautious pace with respect to both new technology, research and new training procedures, making moves forward with higher resources, chronological or personnel investment much more hindered than average as compared to other transport industries such as public transportation. The amalgamation of these previously mentioned drawbacks proves a quintessential result of the ever-important financial aspect. Since much more difficulty is being faced at the current time within the industry itself and the industry must possess a higher par to which virtual reality must operate and yield results, designing and manufacturing virtual reality devices or training programs for these specific industrial with minimum error and low failure rates comes at an incredibly high price tag. The unnecessary pump to the price tag makes most airline investors weary of investing in virtual reality systems to incorporate their usage in aviation.

## **9. CONCLUSION**

At the end of the day, pilots, engineers, designers, investors, airspace users and perhaps an average passenger with basic knowledge of the aviation industry must ask a question: Even though the industry in one way or another has used augmented virtual reality in one way or

another and managed to progress so far, why is there still taboo towards technology that evidently works? Technology that clearly helps? Are a few downsides worth the mass avoidance? – The future for virtual reality is definitely one of the brightest as of late and will assist in progressing multiple industries much further. Aviation has certainly joined the wagon. But will the industry up and above boost the usage of the technology to its maximum potential?

## REFERENCES

- [1] "Civil simulator manufacturer strategies compared" - Murdo Morrison (25 June 2018) on flight global.
- [2] "Transfer of Training from a Full Flight Simulator vs. a High-Level Flight Training Device with a Dynamic Seat" Andrea L. Sparko, Judith Bürki Cohen USDOT/RITA/Volpe National Transportation Systems Center, Cambridge, MA 02142, Tiau H. Go Nanyang Technological University, Singapore 639798. <https://rosap.ntl.bts.gov/view/dot/8949>
- [3] 14 CFR 60 – Flight simulation training device initial and continuing qualification and use. US-FAA - <https://www.gpo.gov/fdsys/granule/CFR-2012-title14-vol2/CFR-2012-title14-vol2-part60>
- [4] "Space Shuttle Landing and Rollout Training at the Vertical Motion Simulator" - Steven D. Beard, NASA Ames Research Center, Moffett Field, CA 94035 - <https://www.aviationsystemsdivision.arc.nasa.gov/publications/2008/AF2008096.pdf>
- [5] "9 Companies Using Augmented and Virtual Reality in Aviation" by Woodrow Bellamy III | August 24, 2017 - <https://www.aviationtoday.com/2017/08/24/9-companies-using-augmented-virtual-reality-aviation/>

### Authors



Fares Ibrahim Elsherbiny



Oleksiy Chernykh

### INFORMATION ABOUT THE AUTHORS

**Fares Ibrahim Elsherbiny** is a graduate of the Air Navigation section of the Faculty of Aerospace Engineering in the University of Politehnica, Bucharest, Romania. He wrote a very well detailed and structured thesis in his bachelors' presentation on the topic of 'trade-off study for a space sealed system' based on the photoprint mars capsule mission and is determined to start his master's degree with another successful paper published being the article on virtual reality in aviation. Throughout his years as a younger student he had attended multiple conferences and youth forums.

**Oleksiy Chernykh** has completed his PhD at age of 27 years old at the National Aerospace University of Ukraine, Kharkov city. He is an Assistant Professor of Department of Civil Aviation Engineering (Nanjing University of Aeronautics and Astronautics, College of Civil Aviation). He has published about 10 papers in reputed journals and reported 14 conference presentations.

## AT THE HELM OF AERONAUTICS

**Diane Uyoga**

Moi University, Kenya  
Head of Department, Aerospace Security and Logistics  
P. O. Box 7256-30100, Eldoret  
e-mail: dianecuyoga@mu.ac.ke

**Key words:** Air transport, safety, self-leadership, aviation, aerospace, aeronautics.

**Abstract.** *Flying as a mode of transportation is one of the safest means of movement from one destination to another. Accidents reported for air transportation cannot be compared to other modes of transportation. Aeronautics, astronauts and pilots have to be at the forefront to ensure that the spaceship and the aircraft are performing according to the expectations. Performance of a spaceship or an aircraft is not about the machines installed or that perfect design. Performance is about the person at the design room or at the drawing board. Performance also is about that person at the controls. Hence good leadership attitude is paramount to the safety of all air transportation. Every individual in the air transport chain is a leader. From the person who designs the spaceship or aircraft to the person who is in control of those spaceships or aircrafts need to have the kind of leadership attitude that put them ahead of their work. Leadership begins with the mindset, and that mindset leads the individual to be at the helm of all the activities that they do.*

### 1. INTRODUCTION

Air transport has seen a continuous rise in demand for it. Essentially, its popularity has been attributed to the fact that it is renowned to be one of the safest modes of transportation. Historical data concerning the safety of airlines show that the all accident rate (measured in accidents per 1 million flights) was 1.08, an improvement over the all accident rate of 1.68 in 2016 and the rate of 2.01 for the previous 5-year period (2012-2016) [1]. Air transport is regarded as the safest mode of transportation, in terms of passenger miles. Assertively, when it comes to a question about risks associated with long-range travel, suitable comparative statistic can be “deaths per billion passenger-kilometers”, hence the reason to name air travel as the safest form of long-range transportation, which clearly shows that the industry is doing something right about safety [2]. The most effective way to ensure and guarantee safety in the industry and maintain the status of the safest mode of transportation starts right at the drawing board, more so at aircraft design stage which evidently requires self-leadership.

## **2. MAIN PART**

### **2.1 Aircraft Design**

This paper focuses on the entire design of an aircraft, be it the systems or the parts that leads to an integration of expertise and amalgamates the skills required to put together the most rewarding and safest design. Designing an aircraft is a very complex engineering task that needs to be decomposed to different levels that are divided into three phases: the conceptual design phase, the preliminary design phase and the detailed design phase [3]. Tasks must be concurrent and coordinated in a way that will achieve an efficient design and its process [4]. Many design problems occur at different stages of aircraft design [5] which points to the importance of having self-leadership in order to accomplish tasks successfully and with minimal mistakes.

### **2.2 Leadership**

The past decade of research on leadership theories has greatly provided insight into the leadership styles and roles. Main focus on the stream of research is on the leadership styles and roles of people who are in the organisational sector, in other words “a made man”. The focus of such leadership models centers on the leader’s communication, creation and implementation of a vision[6].Leadership through the blended soft and hard skills achieved through human resources helps in managing the emotions, egos, and feelings of the people successfully [7]. Research on leadership has traditionally focused on designated leaders in organizations which centered on what personal traits and attributes make a good leader (e.g. intelligence, personality, value, and skills), and what kinds of leadership styles and behaviours (e.g. transformational and transactional leadership, dyadic exchange, adaptive leadership, and ethical leadership) are effective [8]. The behaviours of a leader are positively related to the effectiveness of the leader (for example, Hassan et al., (2013); Brown et al., 2005; De Hoogh and Den Hartog, 2008; Kalshoven et al., 2011; Kim and Yukl, 1995). Leaders facilitate sharing of knowledge as well as guiding mental shifts [9] towards greatest designs of aircrafts that are safe. Generally, there should be an improvement in the overall organizational behavior in terms of time of response [10] to aircraft design through self-leadership.

### **2.3 Self-Leadership**

Leaders lead a balancing act between learning from within which include self and awareness-raising and learning from without by use sources of learning that originate from outside a company [11]. Engineers and other aerospace professionals should have the right attitude and behaviour to ensure that their tasks are efficient and effective. This attitude does not have to start from the organisation, but it starts right with the people who have knowledge and skills to tackle their careers. If leadership is about achieving goals through others, then self-leadership is achieving goals through self. According to Rao’s 11Cs, it is ascertained that leadership can be cultivated by individuals by acquisition of the following characteristics; character, charisma, conscience, conviction, courage, communication, compassion, commitment, consistency, consideration and contribution. When a person has these characteristics self-leadership can be achieved and attained which ensures that, that aircraft design will be the safest.

This paper is built on the remarks raised by Janson & McQueen, (2007) that there is need for foundations to be laid for the development of a self-diagnosing tool to be used by leaders to expose elements linked with other belief systems and attitude about achieving success. Success is achieved when air transport is declared as the safest mode of transportation. Self-leadership can be achieved by acquisition of specific skills that enables a

person to be a leader of one self, to set their own goals and to achieve them successfully. For this reason, is air transport the safest mode of transportation because the engineers or other aerospace professionals engage in self-leadership?

This paper focuses on the attitude and behavior of people towards self and other people around them. It adopts leadership as the process of setting one's own goals, aligning energies and efforts towards achievement of these goals. Here, with focused energy and efforts it translates to successful tasks at the workplace hence being a leader in that particular task.

#### **2.4 Aircraft Design and Self Leadership**

The present research paper focuses towards the contribution to knowledge on self-leadership. It addresses the questions of does one become a leader of self? Does the self-leadership lead to expected results? This is formed from the knowledge that our brains form the basis for our actions and confidence in doing those actions [11]. Self-leadership is the quest for persons to excel through personal actions on assigned tasks that need to be carried out successfully. Therefore, the premise of this paper is that, before a person becomes effective in the assigned tasks, it starts with the attitude and behaviour that the person has.

There is an increased pressure to combine leadership attitudes and behaviour with specialist roles, research and practice discussions that are tending to focus on difficulties of the translation from being a specialist to being a leader in the tasks undertaken and the frequently-suggested incompatible nature of the professional and the leadership role for example: Pelz and Andrews, 1976; Raelin, 1986; Schein, 1996; Fincham, 1996; Mulec, 2006 more importantly a self-leader. Such difficulties have been found in a number of professions and industries, e.g. among design engineers in the aerospace industries[12]. Since human errors are considered to contribute to more than 70 per cent of aviation accidents [2]. This difficulty of not realizing self-leadership in aircraft design can be explained by the following accidents.

According to Tom Brokaw (2000) on September 8, 1994, a USAir Boeing 737 fell from the sky nosefirst and slammed into a wooded area near a small shopping center in Hopewell Township, PA. The aircraft shattered on impact and all 137 people aboard Flight 427 were killed. Reason: Investigators discovered that the Boeing 737's rudders can jam on rare occasions.

Just to name but a few of accidents that occurred due to faulty design as listed in Wikipedia (2018) are:

1. On February 1, 2003, the Space Shuttle Columbia disintegrated upon reentering Earth's atmosphere, killing all seven crew members. Reason: a faulty design.
2. On 3 March 1974, Turkish Airlines Flight 981 was a scheduled flight from Istanbul Yesilköy Airport to London Heathrow Airport, crashed into the Ermenonville Forest, outside Paris, killing all 346 people on board. Reason: a faulty design.
3. On June 12, 1972, American Airlines Flight 96 from Los Angeles to New York the left rear cargo door blew open en route between Detroit and Buffalo above Windsor, Ontario. Reason: a faulty design.

### **3. CONCLUSIONS**

Does a person who give the best designs or good test procedures possess the positive self leadership attitude and behaviour?

## REFERENCES

- [1] <https://www.iata.org/pressroom/pr/Pages/2018-02-22-01.aspx>
- [2] John Pourdehnad, Peter A.C. Smith, (2012) "Sustainability, organizational learning, and lessons learned from aviation", *The Learning Organization*, Vol. 19 Issue: 1, pp.77-86
- [3] AidanJungo, Mengmeng Zhang, Jan B. Vos, Arthur Rizzi, (2018) "Benchmarking New CEASIOM with CPACS adoption for aerodynamic analysis and flight simulation", *Aircraft Engineering and Aerospace Technology*, Vol. 90 Issue: 4, pp.613-626.
- [4] Kikuo Fujita and Shin'ichi Kikuchi (2003). Distributed Design Support System for Concurrent Process of Preliminary Aircraft Design. *CONCURRENT ENGINEERING: Research and Applications*. Volume 11 Number 2
- [5] Valeriy A. Komarov, Andrey V. Boldyrev, Anton S. Kuznetsov, Marina Yu. Lapteva, (2012) "Aircraft design using a variable density model", *Aircraft Engineering and Aerospace Technology*, Vol. 84 Issue: 3, pp.162-171
- [6] Kevin S. Groves, (2006) "Leader emotional expressivity, visionary leadership, and organizational change", *Leadership & Organization Development Journal*, Vol. 27 Issue: 7, pp.566-583
- [7] M.S. Rao, (2013) "Soft leadership: A New Direction To Leadership", *Industrial and Commercial Training*, Vol. 45 Issue: 3, pp.143-149
- [8] Ying Hong, Victor M. Catano, Hui Liao, (2011) "Leader emergence: the role of emotional intelligence and motivation to lead", *Leadership & Organization Development Journal*, Vol. 32 Issue: 4, pp.320-343
- [9] Politis, J.D. (2002), "Transformational and transactional leadership enabling (disabling) knowledge acquisition of self-managed teams: the consequences for performance", *Leadership & Organization Development Journal*, Vol. 23 Nos 3/4, p. 186
- [10] B. Soltanmohammad, S.M. Malaek, (2008) "A new method for design cycle period management in aircraft design process", *Aircraft Engineering and Aerospace Technology*, Vol. 80 Issue: 5, pp.497-509
- [11] Annick Janson, Robert J. McQueen, (2007) "Capturing leadership tacit knowledge in conversations with leaders", *Leadership & Organization Development Journal*, Vol. 28 Issue: 7, pp.646-663
- [12] Causer, G. and Jones, C. (1996), "One of them or one of us? The ambiguities of the professional as manager", in Fincham, R. (Ed), *New Relationships in the Organised Professions: Managers, Professionals and Knowledge Workers*, Avebury, Aldershot.
- [13] Katharina Mulec, (2006) "Positive professional leaders: aspects to consider in leadership development", *Leadership & Organization Development Journal*, Vol. 27 Issue: 1, pp.66-81

[14] Shahidul Hassan, RubináMahsud, Gary Yukl, Gregory E. Prussia, (2013) "Ethical and empowering leadership and leader effectiveness", Journal of Managerial Psychology, Vol. 28 Issue: 2, pp.133-146

[15] [https://en.wikipedia.org/wiki/List\\_of\\_aircraft\\_structural\\_failures](https://en.wikipedia.org/wiki/List_of_aircraft_structural_failures)



## OVERALL DESIGN AND ENERGY ESTIMATE OF HALE SOLAR-POWERED UAV

Mingjie Zhong<sup>1</sup>, S.V.Mrykin<sup>2</sup>

1 – Beihang University, School of Aeronautic Science and Engineering  
XueYuan Road, 37.

100083, Beijing, China

e-mail: zmjzhong@126.com

2 – Samara State University, Department of Aircraft Engineering

Moskovskoe sh., 34. 443086, Samara, Russia

e-mail: mvs101101@rambler.ru

**Keywords:** High altitude; Long endurance; Solar-powered UAV; Overall design; Flight profile

**Abstract:** *Based on André NOTH's design methodology of long-endurance solar-powered airplane, a modified methodology was developed with further considering high altitude, flying wing and sweepback. Meanwhile, a flight plan consisting of climbing to store energy in the daytime and gliding at night and combining with Li-battery are adopted. The method includes mass, power, efficiency and consumed energy estimations of each subpart, also adopts precise solar radiation intensity model, and evaluates the rationality of structure weight. Besides, continuous flight simulation of energy stored in batteries and both available and required power illustrate nearly fifth battery energy is saved during gliding that greatly reduced take-off mass.*

### 1. Introduction

High altitude, long endurance and solar powered UAVs (HLS-UAV) absorb inexhaustible energy from solar radiation and work at near space continuously. Due to its unique altitude and long endurance, it has broad applications in agricultural surveillance and atmospheric exploration, especially relay communication. Compared with terrestrial relay communication systems and satellite system, it not only has much broader coverage than the former one, reusable than the latter one, but also cheaper and more flexible than them.

Sweepback flying wing is a new layout adopted by solar-powered aircraft just recently. Well-known solar-powered UAVs, such as ERAST project, Zephyr and Solara, generally are conventional layout or straight wing looking like a rectangle, being weak in lift-to-drag ratio and lateral stability respectively. The "Helios" in ERAST project seriously crashed in 2003 because of nonlinear stability and control problema [1]. Therefore, sweepback flying wing both remains high lift and improves the stability with sweepback is a way to solve the problem. This configuration has already be verified by Aquila [2], which built by Facebook and accomplished its first full-scale functional check flight on June 28, 2016. Therefore, Aquila is used as the calculation model of the methodology.

In order to save energy during night for decreasing weight of Li battery and take fully advantage of solar energy, a flight profile gliding during night is considered, which can be

verified by analyzing energy simulation at the end. Therefore, referring to Aquila, it climbs to 27km during day and glides to 18km during night.

The article proposed a modified methodology to determine overall parameters for HLS-UAVs and the flight profile in conceptual design, and it is slightly different from the methodology developed by André NOTH[3] that has not considered operating at different altitude in near space and wing loading limitation of flying wing.

## 2. Solar irradiance model and Overall design method

### 2.1. Atmosphere and solar irradiance model

As operating at extremely high altitude for UAVs, considering tremendous atmospheric change is necessary. According to ‘U.S. Standard Atmosphere Air Properties’[4] and Federal Acquisition Regulation (FAR)[5], the comparison between sea level, 18km and 27km(Table.1) obviously shows that the density decreases dramatically from ground to 27km, which will have a huge impact on Reynolds number and level flight speed.

Table.1 Comparison of atmospheric parameters at different altitude

	Altitude/km	Density (kg/m <sup>3</sup> )	Pressure/ (10 <sup>5</sup> Pa)	Temperature/ °C	Viscosity/ (10 <sup>-5</sup> kg· s/m <sup>2</sup> )	Wind speed/ (m/s)
Day	27	0.028	0.017	-55.8	1.46	8.86
Night	18	0.115	0.072	-63.6	1.42	4.09
Ground	0	1.226	1.013	15	1.79	5

Solar irradiance model is one critical part in designing a solar UAV, because all energy and power whether for propulsion system or recharging battery come from the sun. Therefore, it's necessary to build a precise solar irradiance model. Many models are applied such as Wang Jian[6] and André NOTH[3], and simplified for flat surfaces without considering different angle between solar beam and different solar panels at different times. Thus, a precise model[7] is adopted, which is directly determined by date, pressure and time are

$$I_0 = \begin{cases} \frac{S_0}{(1 + 0.3m_a)} R^2, & t_{sr} \leq t \leq t_{ss} \\ 0 & , t \leq t_{sr}, t \geq t_{ss} \end{cases} \quad (1)$$

in which,  $S_0$  - solar const: approximately equal to 1353 kW/m<sup>2</sup> [8],  $R = \frac{1-E^2}{1+E \cos(78^\circ + \frac{\varphi_s}{\pi} 180^\circ)}$

,  $E = 0.0167$  - orbit eccentricity,  $\varphi_s = 2\pi \frac{D-81}{365.25}$  - latitude angle for the sun,  $D$  - number of days from the beginning of the year;

$$m_a = \frac{P}{P_0} \times \begin{cases} 0.121(\theta - 60^\circ) + 2 & , 60^\circ < \theta \leq 75^\circ \\ 0.658(\theta - 75^\circ) + 3.82 & , 75^\circ < \theta \leq 85^\circ \\ 2.48 (\theta - 85^\circ) + 10.4^\circ & , 85^\circ < \theta \leq 87^\circ \\ 4.43 (\theta - 87^\circ) + 15.36 & , 87^\circ < \theta \leq 88^\circ \\ 10.1 (\theta - 88^\circ) + 19.79 & , 88^\circ < \theta \leq 90^\circ \end{cases} \text{ - optical mass}$$

,  $P$  – atmospheric pressure at flight altitude,  $P_0 = 101325 Pa$  – standard atmospheric pressure,  $\varphi$  - flight latitude  $\theta = \arccos(\sin \varphi \sin \delta + \cos \varphi \cos \delta \cos \omega)$  - Zenith,  $\omega = \pi(1 - \frac{t}{12})$  - Sun angle by time and hour angle of the sun,  $\delta = e \sin \varphi_s$  - solar declination,  $e = 23.45^\circ$  - ecliptic inclination angle.

Therefore, a specific solar model (Fig. 1) in latitude  $39.91^\circ$  is built. Moreover, both of solar radiation variation during a day and maximum solar radiation intensity vary slightly with time and altitude (Fig. 2).

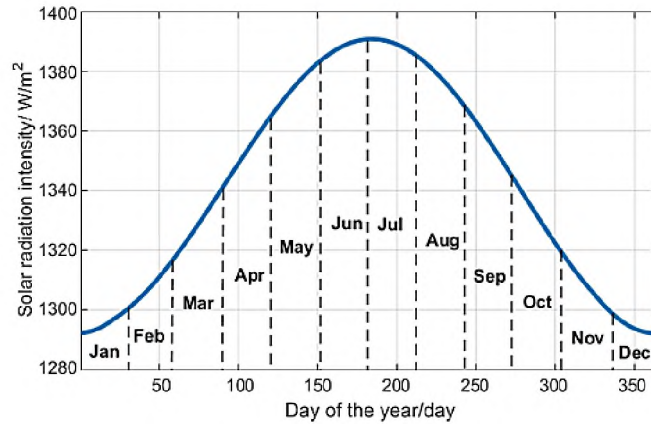

Fig. 1. Solar radiation intensity throughout the year

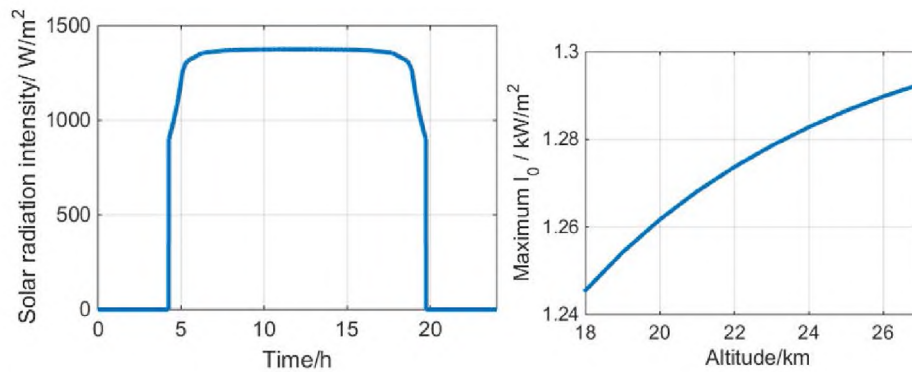

Fig. 2. Solar radiation during a day(left) and maximum solar radiation intensity(fight)

## 2.2. General Iterative Method

The methodology simply needs to input initial main parameters: take-off mass, wing loading, aspect ratio, lift coefficient and lift-to-drag ratio, then output configuration parameters, flight status, mass and power. The Fig. 3 shows very details of mass and power calculation and iteration of the HLS-UAV. Within the iteration, rationality of wing loading, airframe mass, cruising speed, required power and mass error are verified.

Take-off mass consists of avionics, payload, airframe and power plants:

$$m^0 = \sum m_i = m_{avi} + m_{pay} + m_{af} + m_{pp} \quad (2)$$

the power plants can be further divided into propulsion system, secondary battery, solar cells and MPPT. According to a large database of commercial motors[3] (Fig. 4), its mass can be got by Linear fitting:

$$m_{mot} = 6.31 + 3.4(P_{mot} / 1000 - 1.1037) \quad (3)$$

with the similar database[3], mass of brushless controller and MPPT are

$$m_{ctrl} = 0.02 + 0.026(P_{ctrl} - 1.1037) \quad (4)$$

$$m_{MPPT} = P_{MPPT} / 2368 \quad (5)$$

a method to calculate mass of prop was developed by Keidel[9]:

$$m_{prop} = 0.12 n_{bl}^{0.391} (d_{prop} \frac{P_{prop}}{1000})^{0.782} \quad (6)$$

in which,  $n_{bl}$  - number of blades;  $d_{prop}$  - diameter of propeller, m;  $P_{prop}$  - power of propeller, W.

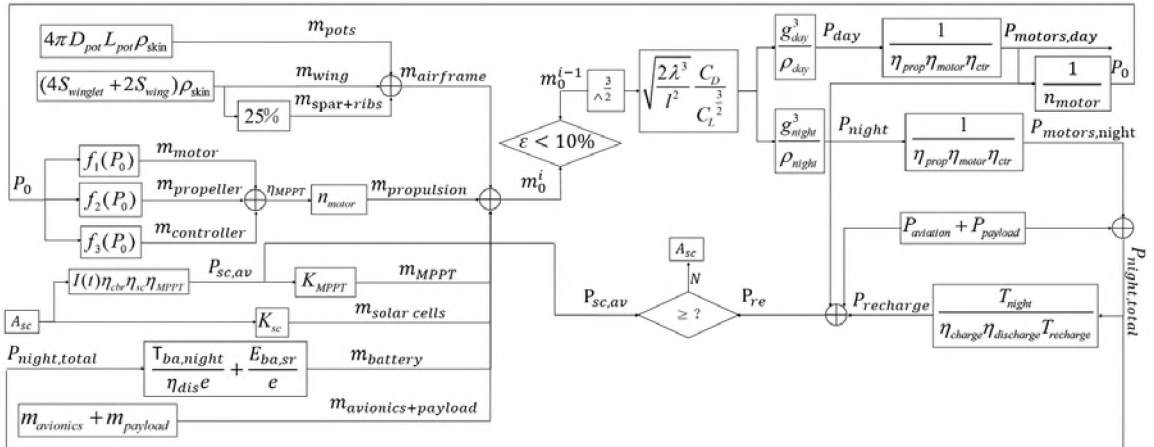

Fig. 3. Iteration idea of overall design

Besides, the airframe mass can be verified by equation which built from solar airplane database [3] only:

$$W_{af} = 0.022S^{1.55}\lambda^{1.3} \quad (7)$$

The power required mainly contains flight, avionics and payload:

$$P_{re} = \frac{P_{flight}}{\eta_{prop}\eta_{motor}} + P_{avionics} + P_{payload} \quad (8)$$

the energy transformation is clearly shown in Fig. 5, which also considers efficiency, flight profile and hybrid power

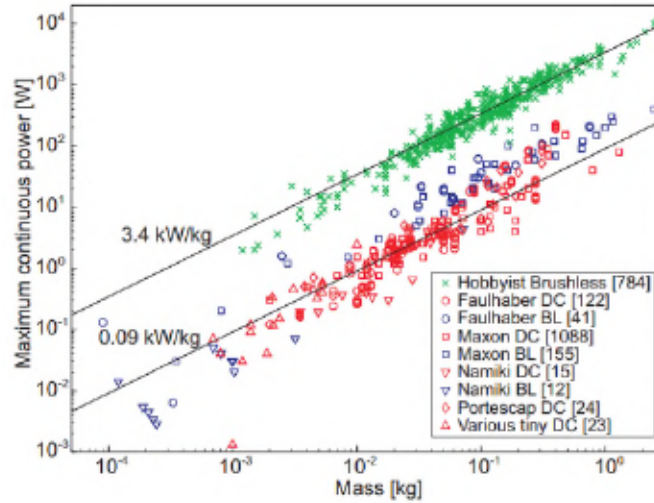

Fig. 4. Power to mass ratio of 2264 commercial motors from a large database[3]

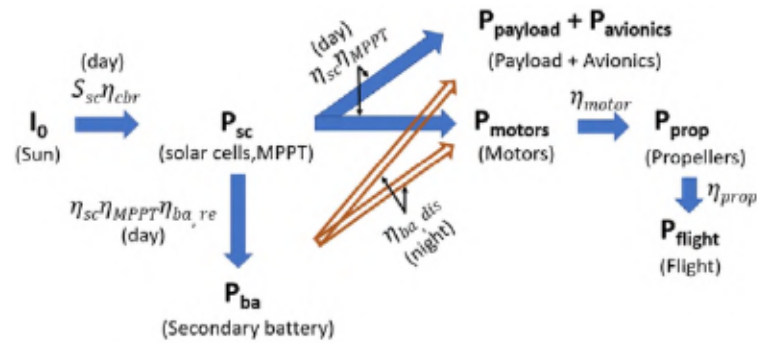

Fig. 5. Energy and power transfer

Efficiency of main subparts are critical to power calculation. Applying same method mass estimation[3], efficiency of motor is

$$\eta_{mot} = 0.3 + 3.15 \times 10^{-4} (P_{mot} - 10^{-2.9}) \quad (9)$$

and a well-designed MPPT should always be higher than 95%[10].

As for the efficiency of propeller, working in high-altitude means in low Reynold number, and will affect propeller efficiency a lot. Colozza A[10] developed an estimation methods for high-altitude flight (up to 30km), which shows that the efficiency is able to reach up to 85% (Fig. 6) over 27km high and specific flight status.

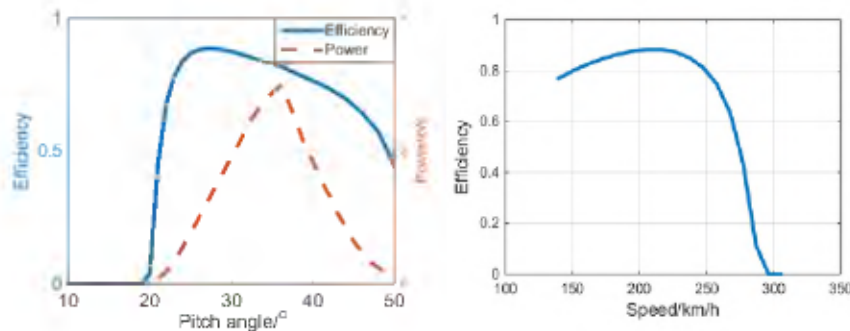

Fig. 6. Efficiency and power varies with pitch angle and speed

### 3. Results and discussion

Configuration (Fig. 7), dynamic parameters (Table 2), configuration parameters (Table 3), weight estimation (Table 4) and power simulation (Fig. 8) are obtained according to the methodology.

From the weight estimation (Table 4), airframe and power plant constitute the majority of take-off mass, which is similar to other solar airplanes. It demonstrates that Li-battery is one of the major issue for long-endurance solar airplanes now, which is supposed to be developed dramatically and widely used with the development of Li-battery in the future.

As the lower density at higher altitude, cruising speed and power for flight during night is nearly half of the day (Table 2). Meanwhile, according to power analysis (Fig. 8), gliding during night can save energy for nearly 2 hours, equal to almost one fifth energy in the Li-battery, which means a lot to the take-off mass. So that descending during night and climbing during day to transfer solar energy to gravitational potential is effective.

Solar energy between 12pm to 18pm and during gliding is wasted, as is shown in Fig. 8, thus decreasing solar cells or climbing to a higher altitude to make fully advantage of solar energy might be feasible. Moreover, recharging and discharging battery during sunset to make full use of solar energy will saving a great amount of battery energy.

According to all results of the weight, power and configuration parameters, it seems that the methodology is feasible for conceptual design, more further work can base on it and get all desired information very quickly. What's more, parameters input to the iteration can be adjusted to suite requirements.

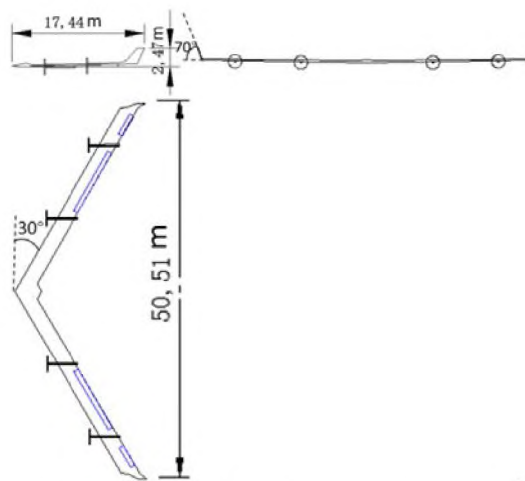

Fig. 7. Initial three views of airplane

Table 2. Main dynamic parameters

Take-off mass $m_0$	Wing loading $p_0$	Flight Power (day) $P_{flight,day}$	Cruising speed (day) $V_{day}$
400 kg	34 N/m <sup>2</sup>	5.85 kW	216.7 km/h
Lift coefficient $C_L$	Drag coefficient $C_D$	Flight Power (night) $P_{flight,night}$	Cruising speed (night) $V_{night}$
0.65	0.0163	2.93 kW	108.0 km/h

Table 3: Aircraft configuration parameters

$S/m^2$	Aspect ratio $\lambda$	Wingspan $l/m$	Wing chord $b/m$
114.4	21	49	2.334
Wing taper $\eta$	Dihedral angle $^\circ$	Lift-to-drag ratio $\frac{C_L}{C_D}$	
1	1.5	40	

Table 4: Results of weight estimation

No	Name	$m_i$ kg	$\bar{m}$	No	Name	$m_i$ kg	$\bar{m}$
I	AIRFRAME	198	0.45	III	AVIONICS	323	0.07
	POWER PLANT	184	0.42	IV	EMPTY AIRPLANE	414	0.94
II	Solar cells	10.7	0.02	V	PAYLOAD	25.0	0.06
	Li batteries	127	0.29	VI	TAKE-OFF MASS $m_0$	439	1.00
	Others	45.9	0.11	III	AVIONICS	323	0.07

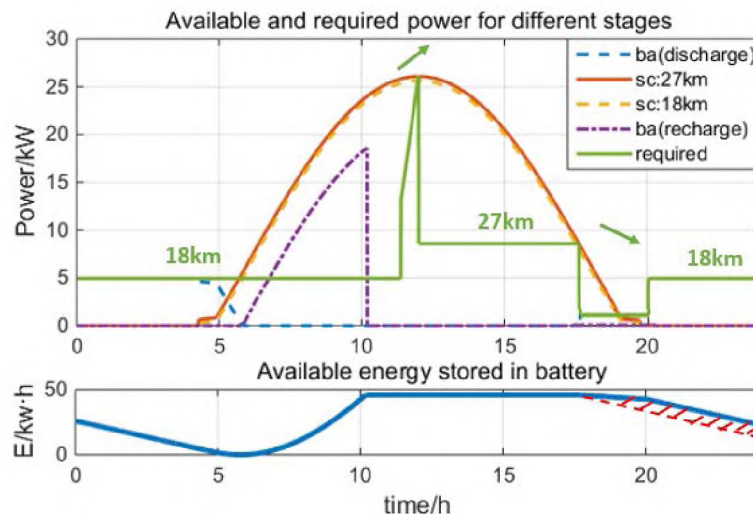

Fig. 8. Energy and power simulation during a whole day

#### 4. Conclusions

With simply inputting some parameter to the conceptual design methodology, basic parameters of a HLS-UAV with sweepback and flying wing configuration are got. It has nearly 50m wingspan, 30 degree's sweepback and wingtips, and is designed to fly between 18km and 27km high.

Meanwhile, a flight plan, climbing to 27km for storing energy in the daytime and gliding to 18km at night, for HLS-UAVs are verified to save nearly one fifth energy of Li-battery (almost 10kw · h in this example), which also saves a great amount of take-off mass.

#### References

- [1] Noll TE, Brown JM, Marla E et al (2004) Investigation of the helios prototype aircraft mishap. NASA Report.
- [2] Martin Luis Gomez, Andrew Cox, Flying Aquila: Early lessons from the first full-scale test flight and the path ahead [EB/OL]. <https://code.facebook.com/posts/268598690180189>, 2016-7-21.

- [3] Noth A. Design of solar powered airplanes for continuous flight [D]. Switzerland: ETH ZURICH, 2008.
- [4] Center N G D. US standard atmosphere (1976)[J]. Planetary and Space Science, 1992, 40(4): 553-554.
- [5] Authority F A. Federal Aviation Regulations Part 23 Airworthiness standards: Normal, utility, acrobatic and commuter category airplanes[J]. Refer Especially to Sections, 23(23.572).
- [6] Wang Jian. Conceptual Design and Energy Management System Optimization for a Blended Wing [D]. Nanjing University of Aeronautics and Astronautics, 2016.
- [7] Tverskoy P.N. (1951) Course on meteorology: atmospheric physics. Hydrometeorol Izdatelstvo, Leningrad (in Russian). L.: GIMIZ, 1962.- 700 p.
- [8] Goswami D Y, Kreith F, Kreider J F. Principles of Solar Engineering, Second Edition[J]. Crc Press, 2000.
- [9] Keidel B. Auslegung und Simulation von hochfliegenden, dauerhaft stationierbaren Solardrohnen[D]. Universität München, 2000.
- [10] Colozza A. High altitude propeller design and analysis overview[J]. Federal Data Systems Cleveland Ohio, 1998, 44135



## Questions of the Students Individual Competition for Aircraft Designing

### General list of questions

#### 1<sup>st</sup> Section. Common terms and topics

Put examples for your answer, which can prove it.

1. Explain how you understand the term – “aviation”.
2. Explain how you understand the term – “designing”.
3. Describe factors that determine an airplane external view.
4. Describe the principle of the airplane’s flight.
5. How can you design an aircraft that does not need runways.

#### 2<sup>nd</sup> Section. Aerodynamics. Put examples for your answer, which prove it.

1. List and write down the basic equations of hydrodynamics.
2. Explain the aerodynamic characteristics of the wing at low Reynolds Number velocities.
3. Describe required airplane performance at approach and landing time until full stop.
4. What is the effect of the atmosphere on the Shuttle descent and from what height
5. Describe how a pitot-static tube is used to measure airspeed

#### 3<sup>rd</sup> Section. Strength. Put examples for your answer, which can prove it.

1. Explain structural strength, stiffness?
2. List and describe main effects of aeroelasticity.
3. What is structural fatigue? Explain with description the main reasons for structural fatigue.
4. Flutter, ways to deal with flutter, give examples from personal observations of the flutter phenomenon.

#### 4<sup>th</sup> Section. Manufacturing. Put examples for your answer, which can prove it.

1. How do you understand term “cooperation” in industry?
2. Please explain term “configuration breakdown”. What is its aim for manufacturing?
3. Please describe the requirements for adapting component design to improve manufacturability in the aviation industry.
4. Explain the advantages and disadvantages of structures made of composite materials

#### 5<sup>th</sup> Section. Design. Put examples for your answer, which can prove it.

1. Please write down and describe the equation of an existing airplane.
2. What are different between concentrated and distributed forces in aviation?
3. Determine load-carrying structure in Figure 1. Name all structural members and write down their functions.
4. Please draw the skeleton diagram of a turboprop engine. Name its main parts and their functions. Explain the principle of this engine operation.
5. Please list and explain the design main features of an airplane can be modified at different phases of life from design concept to aircraft retrievalment.

## Questions of the Students Individual Competition

6. Please list and explain main stages of an airplane certification procedures.
7. What are the four forces of flight, and for an aircraft in steady, level flight, how are they related ?
8. Describe the concept of “balanced field length” when determining the required takeoff field length of a commercial aircraft
9. Describe the requirements of the pitching moment coefficient and longitudinal stability derivative coefficient for longitudinal static stability of an aircraft.
10. What are some of the advantages and disadvantages of a canard configuration, both from design and operational aspects?
11. Vortex generator have two primary purposes. What are they?
12. What is the purpose of wing flaps, and why are they often used on an aircraft?
13. Why is the tricycle landing gear preferred over the older tail-dragger type of landing gear, and what is the cause of the different characteristic that results in that preference?
14. All large commercial aircraft of recent design have the engines in nacelles located under the wing. Why is that preferred to having the engines located at other positions such as within the wing root (which gives less drag), on top of the wing, or at the rear of the fuselage (which allows more space for trailing edge flaps)?
15. Why are wings swept back, rather than forward? Give at least one reason.
16. Conditions: Two gliders, A and B, geometrically identical. Glider A weighs 500 kg, glider B weighs 600 kg. Both are flying at their speed for minimum glide angle. Starting from the same location in the air –
  - a. Which one will fly the furthest: A, B, or both the same?
  - b. Which one will reach the ground first: A, B, or both the same?
17. Please complete request for proposals for a civil aircraft of a certain purpose that, in your opinion, the need at the nearest future is highest. Prove the basis of your proposal. Do a base calculation and draw its sketch.
18. Determine the parameters, select the scheme and power plant unmanned AIRCRAFT for a flight at a distance of 10,000 km.

## Questions selected for the competition

**1<sup>st</sup> Section. Common terms and topics** (maximum points – 5). Put examples for your answer, which can prove it.

Explain how you understand the term – “aviation”.

**2<sup>nd</sup> Section. Aerodynamics** (maximum points – 10). Put examples for your answer, which prove it.

Describe required airplane performance at approach and landing time until full stop.

**3<sup>rd</sup> Section. Strength** (maximum points – 10). Put examples for your answer, which can prove it.

List and describe main effects of aeroelasticity.

**4<sup>th</sup> Section. Manufacturing** (maximum points – 10). Put examples for your answer, which can prove it.

How do you understand term “cooperation” in industry?

**5<sup>th</sup> Section. Design.** Put examples for your answer, which can prove it.

Questions of the Students Individual Competition

- 5.1. What are different between concentrated and distributed forces in aviation? (maximum points – 10)
- 5.2. What are the four forces of flight, and for an aircraft in steady, level flight, how are they related ? (maximum points – 10)
- 5.3. Please complete request for proposals for a civil aircraft of a certain purpose that, in your opinion, the need at the nearest future is highest. Prove the basis of your proposal. Do a base calculation and draw its sketch. (maximum points – 45)

**The questions authors**



*Anthony P. Hays*  
California State University Long Beach,  
California (USA)



*Dmytro V. Tiniakov*  
Nanjing University of Aeronautics and  
Astronautics, (China)

**Jury**

*Anatolii  
Kretov*

*Oleksiy  
Chernykh*

*Oleksandr  
Moliar*

*Dmytro  
Tiniakov*

*Anthony P.  
Hays*





## AWADE PARTICIPATION IN THE SEMINAR WORK OF READ-EWADE-2018

Pinqi Xia<sup>1</sup>, Anatolii Kretov<sup>2</sup>, Oleksiy Chernykh<sup>3</sup>, Dmytro Tiniakov<sup>4</sup>

Nanjing University of Aeronautics and Astronautics

29 Yudao St., Nanjing 210016, P.R China

1, 2 – College of Aerospace Engineering

3, 4 – College of Civil Aviation

e-mail: 2 – [kretov-ac@nuaa.edu.cn](mailto:kretov-ac@nuaa.edu.cn)

3 – [alex@nuaa.edu.cn](mailto:alex@nuaa.edu.cn)

4 – [tinyakov\\_dm@mail.ru](mailto:tinyakov_dm@mail.ru)

**Key words:** AWADE, READ, EWADE, seminar, Aircraft Desing.

**Abstract.** *This paper contents information about seminar READ-EWADE-2018 and participation AWADE in work of this seminar*

### 1. INTRODUCTION

On November 6-9, 2018, in Brno University of Technology in the Institute of Engineering (Czech Republic) the seminar of READ (Research and Education in Aircraft Design) and EWADE (European Workshop on Aircraft Design Education) was hold.

The member of the AWADE Organizing Committee Dr. Oleksiy Chernykh took part in this seminar.

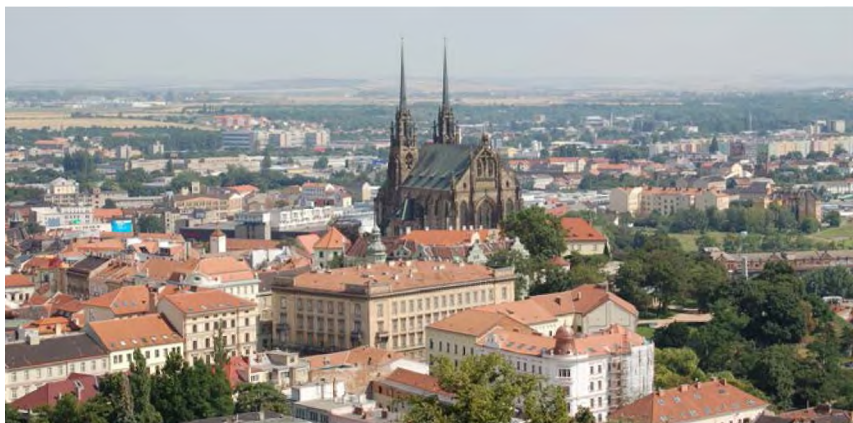

*a*



*b*

Fig.1. *a* – Brno is the one of the best city of Czech Republic;  
*b* – the building of the Institute of Engineering of Brno University of Technology

## 2. WORK PROGRAM OF READ AND EWAD 2018

7.11. 2018 WEDNESDAY							
8:00	9:00	REGISTRATION					
		Neo-baroque hall		Conference room A		Conference room B	
		Session	Authors/ Title	Session	Authors/ Title	Session	Authors/ Title
9:00	9:20		introduction and welcome speech				
9:20	10:20	Plenary Lecture	Milan Štápek GE Aviation Czech				
10:20	10:40	Coffee break					
		Session I-A	Student session - Aerodynamics and Flight Mechanics	Session I-B	Aircraft Design	Session I-C	Aircraft Systems and Security
		Chairman:	Tomasz Goetzendorf-Grabowski	Chairman:	Jaroslav Juracka	Chairman:	Jiri Hlinka
10:40	11:00	AERO-S	Pratik Meghani A 2D Aerodynamic Study on Morphing in the NACA 2412 Airfoil	DESIGN	Agnieszka Kwiek Conceptual Design of an Aircraft for Mars Mission	SYS	Luboš Janhuba, Rostislav Košťál and Jiri Hlinka Integrated Method utilizing Graph Theory and Fuzzy Logic for Safety and Reliability Assessment of Airborne Systems
11:00	11:20	AERO-S	Katarzyna Pobikrowska and Tomasz Goetzendorf-Grabowski Stability Analysis of the Experimental Airplane Powered by a Pulsejet Engine	DESIGN	Petr Augustin Simulation of Fatigue Crack Propagation in the Wing Main Spar Flange	SYS	Sebastian Topczewski, Antoni Kopyt, Przemysław Bibik and Marcin Zugał Development of an Automatic System for Helicopter Autopilot Performance Evaluation
11:20	11:40	AERO-S	Wojciech Szlachetko Simple Universal Nonlinear Longitudinal Flight Simulation with Avoiding of Static and Dynamic Divergence	DESIGN	Jakub Šedík Numerical Analysis of Magnetoelastic Rivet Joint and the Technique for Its Stiffness-Equivalent FF Substitution	SYS	David Štepec Diagnostic Parameters Determination of Aircraft Hydraulic System
11:40	11:50	Break					
11:50	12:10	AERO-S	Ugyen Wangchuk Finding the Optimum Active Laminate Flow Control Design Using Continuous Section for Airbus A320XLR	DESIGN	Miroslav Cervenka and Rostislav Košťál Layout Optimisation for Active Structure Health Monitoring	SYS	Antoni Kopyt, Przemysław Bibik and Grzegorz Świętoń An Implementation and Verification the Objective Assessment Tool for Pilots' Performance Measurement
12:10	12:30	AERO-S	Jakub Mlýnský A Review of the Analytical Methods used for Seaplanes Performance Prediction	DESIGN	Włodzisław Gronowicz Multidisciplinary Wing Design of a Light, Long Endurance Unmanned Aerial Vehicle	SYS	Stefano Diopoli Advanced Technologies and Methodologies for Engine Control Design
12:30	12:50	AERO-S	Grzegorz Szlachetko The Approximation Method in the Problem on a Flow of Viscous Fluid Around a Thin Plate				
12:50	13:50	Lunch					
13:50	14:20	Plenary Lecture	Zdobych Goni, Tolibekbek Mirzayev Stress, Strain and Displacement Analysis of Geodetic and Conventional Fuselage Structures for Future Passenger Aircraft				
		Session II-A	Aerodynamic and Flight Mechanics	Session II-B	Material and Technology in Aeronautics		
		Chairman:	Robert Popela	Chairman:	Ivo Jebacek		
14:30	14:50	AERO	Marco Evangelos Bencolini, Ubaldo Cella, Corrado Groch and Emiliano Costa Fast High Fidelity CFD/CFM Field Structure Interaction Using MBF Mesh Morphing and Modal Superposition Method	DESIGN-S	Viktor Karabut, Vitaly Dudnik and Ilya Zhuravskiy Preliminary Optimization of Composite Blades for "Blend" Light Helicopter		
14:50	15:10	AERO	Tomasz Goetzendorf-Grabowski and Jacek Mieloszyk The Influence of the Propeller Slipstream in 3D Panel Method	DESIGN-S	Frantisek Loffelmann and Jan Splichal Design Study of the Heat Switch Base Plate with Help of Topology Optimization		
15:10	15:30	AERO	Marek Pátek The Aerodynamic Design of the Aircraft in Tandem Wing Configuration	DESIGN-S	Peter Žubík and Michal Kováčik Composite Aircraft Joint Experimental Testing with Digital Image Correlation		
15:30	15:40	Coffee break					
16:00	16:20	AERO	Robert Kulhanek Identification of a Degradation of Aerodynamic Characteristic of a Paraglider due to its Flexibility from Flight Test	MAT-S	Igor Skawinski and Tomasz Goetzendorf-Grabowski FEM 3D Pricing Method Utility Assessment in Small RC Aircraft Design		
16:20	16:40	AERO	Jacek Mieloszyk and Andrzej Tarnowski Improvements in Conceptual Electric Aircraft Design	MAT-S	Matteo Pontecorvo Design of Manufacturing, Simulations of a Composite Paint and Heat Pipe		
16:40	17:00			SYS-S	Wojciech Szlachetko Fracture Aircraft-yllot Interaction Device for Spatial and Movement Guidance: a Research of the Encoding Possibilities of the Distance Information with Microscopic Feedback		
19:00	23:00	Social event- Rectorate atrium					

8. 11. 2018 THURSDAY								
REGISTRATION								
		Neo-baroque hall		Conference room A		Conference room B		
		Section	Authors/ Title	Section	Authors/ Title	Section	Authors/ Title	
9:00	10:00	Plenary Lecture	Stefan Klein Air Car	-	-			
10:00	10:30	Coffee break						
		Session III-A	<b>Aircraft Design Materials and Technology in Aeronautics</b>	Session III-B	<b>Student session: Aircraft Systems and Security Aeronautical Transport</b>			
		Chairman: Zdobyslaw Goraj		Chairman: Allan Nömmik				
10:30	10:50	DESIGN	Tomasz Katrňák, Jaroslav Juracka and Ivo Jebáček	MAT-S	Jakub Masek		Conference New Trends in Civil Aviation	
			Effect of Defects on Buckling of Stiffeners of Aircraft Structures		Thermal Conductivity of Cu7.2Ni1.8Si1Cr Copper Alloy Produced via SLM and Ability of Thin-Wall Structure Fabrication			
10:50	11:10	MAT	Radek Doubrava, Martin Oberthor, Milan	SYS-S	Łukasz Wolski			
			Verification and Numerical Simulation of Advanced Composite Inlet in Compliance of Airworthiness Impact Requirements		Beyond Visual Line of Sight UAV Communication System			
11:10	11:30	MAT	Ilmars Blumbergs, Martins Kleinhofs, Rafal Chatys and Alexander Panich	SYS-S	Marek Łukasiewicz, Przemysław Bibik and Konrad Łukasik			
			Destructive Process Models of Composite in Case of Coupled Environment Fracture Model		Precise Manoeuvre Guidance System for UAVs using Machine Vision			
11:30	11:50			TRAN-S	Anrieta Dudoi and Jonas Stankunas			
					Horizontal Conflict Resolution in Free Route Environment			
11:50	12:10			TRAN-S	Peter Kalavský, Róbert Rozenberg, Pavol Petriček, Vladimír Socha and Luboš Socha			
					Rope Procedures for Extraction and Insertion of Persons Used by Helicopter Emergency Medical Service			
12:10	13:10	Lunch						
13:10	14:10	Plenary Lecture	Blanka Lenczowski Airbus	-	-			
			New Product Design for Aerospace by Applying New Material Technologies					
		Session IV-A	<b>Aircraft Design - Research and Education (EWADE) Aerospace Education (REA/E)</b>	Session IV-B	<b>Aircraft Systems and Security Aeronautical Transport</b>			
		Chairman: Oleksiy Chernykh		Chairman: Luboš Janhuba				
14:10	14:30	EDU	Tomasz Rogalski	SYS	Pavel Zikmund		Conference New Trends in Civil Aviation	
			In-Flight Tests in Students Projects		Haptic feedback in Pilot-Aircraft Interaction			
14:30	14:50	EDU	Ingo Staack	SYS/DESIGN	Jan Splichal and Jiří Hlinka			
			Establishment of the Swedish Aeronautical Research Center (SARC) to Foster National Education, Research and Industry Cooperation		Modelling of Health Monitoring Signals and Detection Areas for Aerospace Structures			
14:50	15:10	EDU	Odile Tissier	SYS	Rostislav Koltsal, Luboš Janhuba and Jiří Hlinka			
			Project-oriented Education: from Engineering School to Engineering Jobs		Aircraft Leading Edges Minor Damages Detection Based on Thermographic Survey of Electrical Anti-Icing System			
15:10	15:30	EDU	Agnieszka Kwiek	TRAN	Allan Nömmik			
			Teaching Aircraft Design Through a Blended Learning Method in a Higher Education		Trends in Development of Aircraft for Regional Routes: Impact on the European Air Transportation System			
15:30	15:50	EDU	Pinqi Xia, Anatolii Kretov, Dmytro Tiniakov, Oleksiy Chernykh	TRAN	Miroslav Splichal			
			AWADE as the Asian Variant of a Workshop on Aircraft Design Education		Reduce Pilot Stress in the Landing Maneuver by Providing Accurate Height Information			
15:50	16:00	Coffee break						
16:00	16:20							
16:20	16:40	Students awards ceremony						
16:40	17:10	Closing Ceremony						
19:00	23:00	Formal/ Informal social evening						

The authors included this program of READ-EWADE-2018, believing that the seminar structure and some reports may be of interest to readers of our Proceedings.

### 3. Report of AWADE as the Asian Variant of a Workshop on Aircraft Design Education

In the seminar work READ-EWADE-2018 Asian Workshop was presented by the report “AWADE as the Asian Variant of a Workshop on Aircraft Design Education”. The presentation was consisted by two parts.

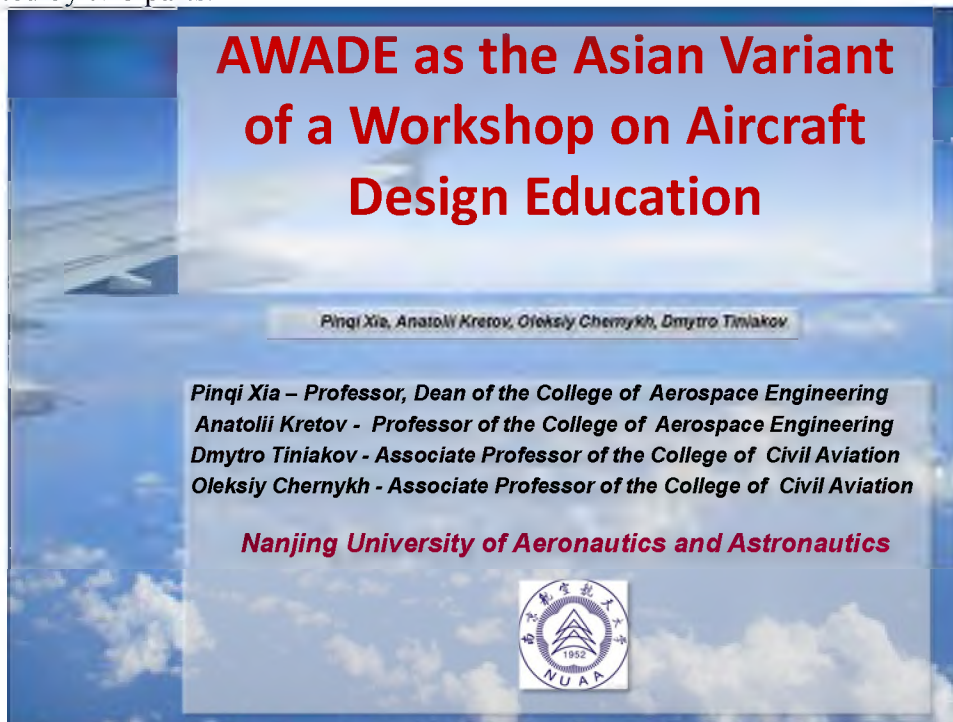

Fig.2. Title page of presentation prepared for READ-EWADE-2018

In the first part (presenter A.Kretoy) the history of creation of the Asian Workshop on Aircraft Design Education, tasks which were put before organizers of AWADE was showed. The program of AWADE-2018 also was considered, that was carried out according to the new formula including simultaneous carrying out of a seminar and student design competition with broad using of Skype conference format. This presentation was built on the Organizing Committee report “Brief history of Asian- and European WADE and program of AWADE 2018” (p.6-10)

The second part (presenter D. Tiniakov) was devoted to the analysis of curricula in areas related to training for the AD major. This part presentation was connected with reports:

*Dmytro Tiniakov* “The Major content of the Curricula on the Airplane Designing Direction in National Aerospace University KhAI” (p.89-03)

*ZhiJin Wang and Anatolii Kretoy* “About curriculums for the foreign Graduate Students Majoring in "Aircraft Design" of NUA” (p.62-68)

*Wen Chih-Yung and Sun Jingxuan* “Project-based Aircraft Design Education at the Hong Kong Polytechnic University” (p.33-41)

*Stephane Tambwe , and Oleksiy Chernykh, and Dmytro Tiniakov* “Online Learning in Aeronautical Engineering Education at Some American Universities (p.143-150)

*Lina Makarova* “Work Experience at the NUA Summer Lecture Program” (p.20-24).  
Aircraft Design Teaching Analysis and Optimization

The aim of the second part of presentation is to highlight present institutions offering courses in AD, compare curricula and provide optimal considerations for further teaching methodology

Pinqi Xia, Anatolii Kretov, Oleksiy Chernykh, Dmytro Tiniakov improvements fitting to Aviation Technology advances. Work on the second part of the presentation showed very important direction the improving the content of curriculum on AD.



Fig.3. Internet connection with READ-EWADE-2018

#### 4. CONCLUSIONS

1. Interaction between AWADE, READ, EWADE significantly expand the range of topical issues related to AD and significantly enrich the experience of all participants.
2. The wide use of Internet contacts in the conference requires improvement of the technical aspects of this cooperation.
3. The research direction about AD training is actual topic, which may help to provide unification of the curricula of different Universities.

#### REFERENCES

- [1] <http://ewade2018.aircraftdesign.org>.
- [2] <http://aircraftdesign.nuaa.edu.cn/AWADE/index.html>

#### Authors



Pinqi Xia



Anatolii Kretov



Oleksiy Chernykh



Dmytro Tiniakov



## A BRIEF REPORT ON THE RESULTS AWADE-2018

### AWADE Organizing Committee

AWADE-2018 was held in Nanjing University of Aeronautics and Astronautics (NUAA) on October 14-17. The Workshop was dedicated to 60th Anniversary of the flight of first Chinese jet JJ-1.

AWADE-2018 included work in two areas: Seminar and Student Design Competition.

26 works were presented at the Seminar. The number of authors was 49 from 13 countries (China, Russia, Ukraine, Germany, Romania, Lithuania, USA, Australia, Uzbekistan, Madagascar, Ghana, Congo and Kenya). During two working days, October 15-16, 4 sessions were held, where 25 reports were heard, including 11 in the format of Skype conference from other universities, one work was presented in the form of a poster report.



The following works were recognized as the best:

*Anthony P. Hays* (California State University Long Beach, USA). Aircraft Design for Reduced Carbon Emissions – as the most informative report on the perspective directions of the future development of aviation.

*Professor Valentin Khaliulin* (Kazan National Research Technical University, Russia) – for a series of presentations of Design and Manufacture of Power Components of Aircraft from Composites – which were made with the broad involvement of students.

*Professor Stanislav Gorb* (Department of Functional Morphology and Biomechanics, Zoological Institute of the University of Kiel, Germany). Structure and Properties of Dragonfly Wings: Composite Structure of Fibrous Material Supplemented by Resilin – as

the most original topic aimed at studying the achievements of natural structures

During the 4th session, in parallel with the Seminar, the personal Student Design Competition (SDC) was held in.

26 bachelor and master students from three universities: NUAA, KhAI (Kharkiv, Ukraine), KAI (Kazan, Russia) announced their participation in SDC. Each participant received eight questions on five topics of aircraft design each of which had the following maximum points:

A BRIEF REPORT ON THE RESULTS AWADE-2018

Section	Maximum points
1. Common terms and topics	5
2. Aerodynamics	10
3. Strength	10
4. Manufacturing	10
5. Design	
5.1	10
5.2	10
5.3	45
Total:	100

The winners were:

1. Vladislav Poliakov, bachelor 4 years, KhAI, Ukraine – 78.8 points;
2. Allan Dias, bachelor 4 years, NUAA, College of International Education – 74.4 points;
3. Hanna Nechyporenko, master 2 years, NUAA, College of Civil Aviation – 73.0 points.

The authors of the best presentations and the student competition participants were awarded the appropriate certificates.



The certificates of the winners of the individual student competition on aircraft design

## CONCLUSIONS

### **AWADE Organizing Committee**

Nanjing University of Aeronautics and Astronautics, College of Aerospace Engineering,  
29 Yudao St., Nanjing 210016, P.R.China

e-mail: [kretov-ac@nuaa.edu.cn](mailto:kretov-ac@nuaa.edu.cn)

### **Common Conclusions**

1. Work of AWADE for three years has shown the importance of this direction.
2. The use of modern computer technology can significantly expand the geography of participants and allows for various forms of the workshop with minimal financial costs and minimal loss of time.
3. Attracting students to AWADE has increased their interest to the aircraft design..

### **AWADE-2018 Conclusions**

4. The geography of the seminar participants has expanded: 26 works were presented at the Seminar. The number of authors was 49 from 13 countries (China, Russia, Ukraine, Germany, Romania, Lithuania, USA, Australia, Uzbekistan, Madagascar, Ghana, Congo and Kenya).
5. The number of reports related to the methodological problems of the organization of education in the field of aircraft design has increased significantly.
6. Ties with European associations in aircraft design continue to be strengthened. Along with EWADE appeared interaction with READ.
7. A new form of AWADE – a student competition – has been tested. 14 bachelor and master students from three universities: NUAA, KhAI (Kharkiv, Ukraine), KAI (Kazan, Russia) took part in personal Student Design Competition (SDC).
8. According to the wishes students, it is necessary in future to hold SDC at the team level in the format of aircraft design.



ASIAN  
WORKSHOP ON AIRCRAFT DESIGN EDUCATION



PHOTO GALLERY  
OF THE THIRD AWADE SEMINAR  
AND THE STUDENT DESIGN COMPETITION  
NANJING

OCTOBER 14-17

2018



Asian Workshop on Aircraft Design Education  
**AWADE 2018**  
Nanjing University of Aeronautics and Astronautics  
(NUAA), 14-17 October 2018

<http://aircraftdesign.nuaa.edu.cn/AWADE/index.html>

## ASIAN WORKSHOP ON AIRCRAFT DESIGN EDUCATION 2018



# ASIAN WORKSHOP ON AIRCRAFT DESIGN EDUCATION 2018



# ASIAN WORKSHOP ON AIRCRAFT DESIGN EDUCATION 2018

## Plenary report: Aircraft Design for Reduced Carbon Emissions

How Tony Hays sees  
the future of aviation

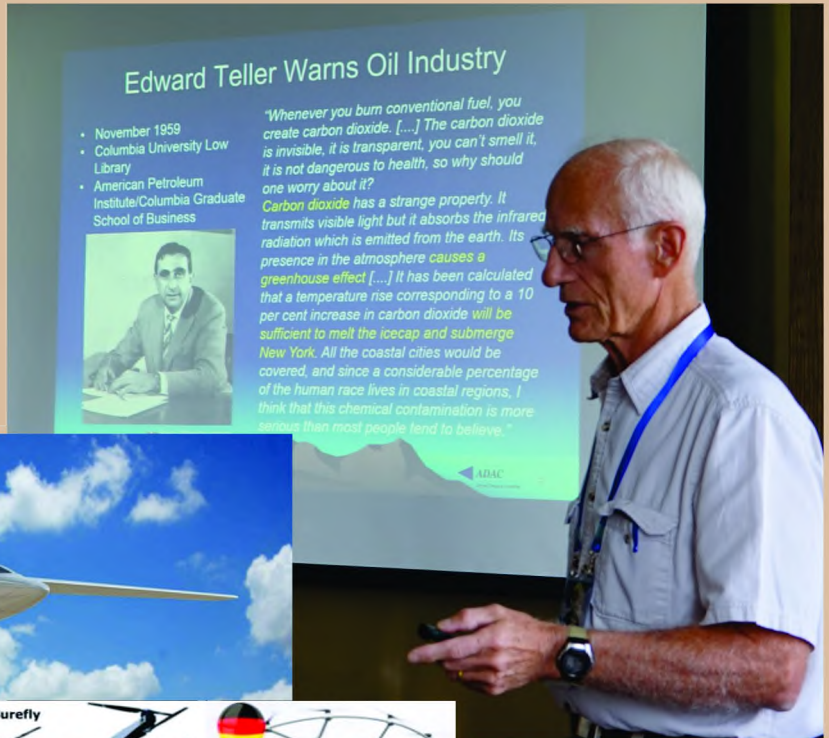

# ASIAN WORKSHOP ON AIRCRAFT DESIGN EDUCATION 2018

**How to Improve  
the Summer  
Lecture  
Program?**





# ASIAN WORKSHOP ON AIRCRAFT DESIGN EDUCATION 2018



Presentation from Australia: Flight on a Passenger Plane as the Process to Study the Aviation Basics



# ASIAN WORKSHOP ON AIRCRAFT DESIGN EDUCATION 2018



**Presentation from Hong Kong:  
Project-based Aircraft Design Education at the Hong Kong Polytechnic University**



THE HONG KONG  
POLYTECHNIC UNIVERSITY  
香港理工大學  
DEPARTMENT OF MECHANICAL ENGINEERING  
機械工程學系



# ASIAN WORKSHOP ON AIRCRAFT DESIGN EDUCATION 2018

A new word in the English language  
**"Ekranoplan"**

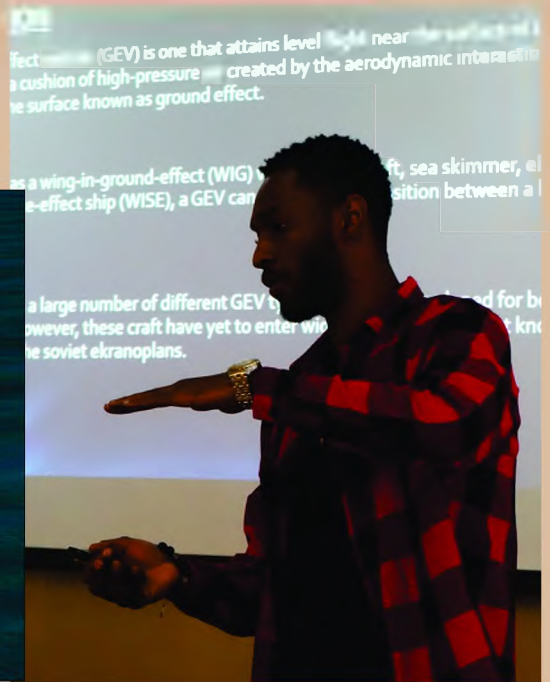

The most important problem in aviation structures is

**"Rigidity"**

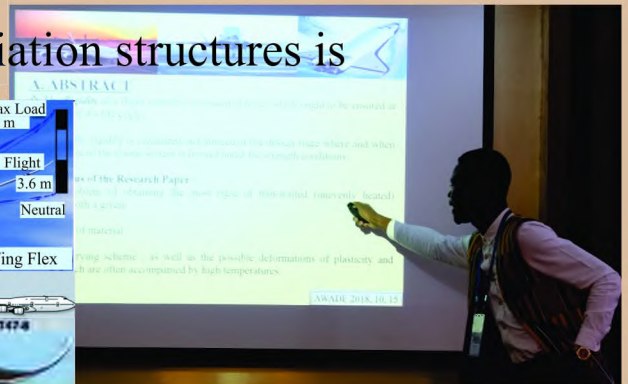

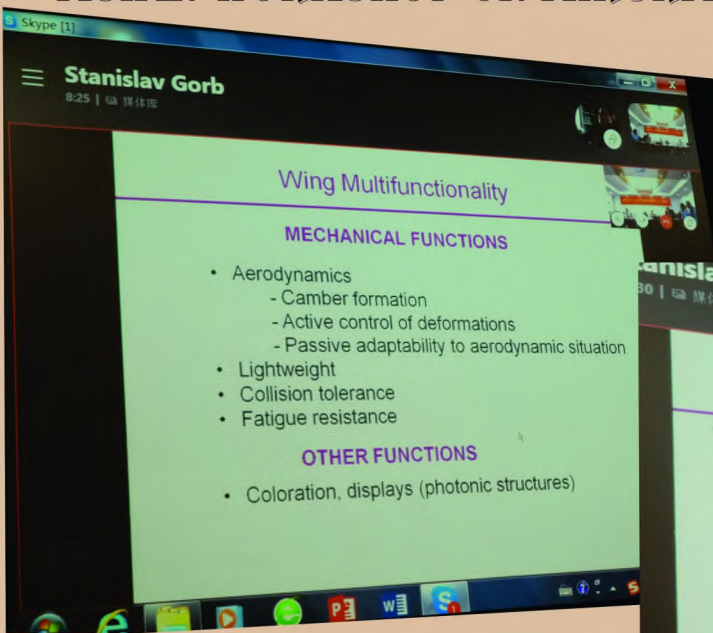

## Structure and Properties of Dragonfly Wings: Composite Structure of Fibrous Material

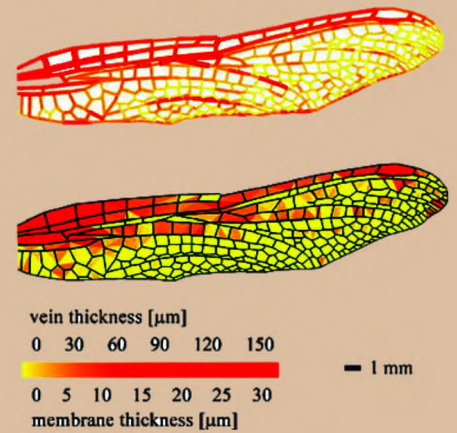
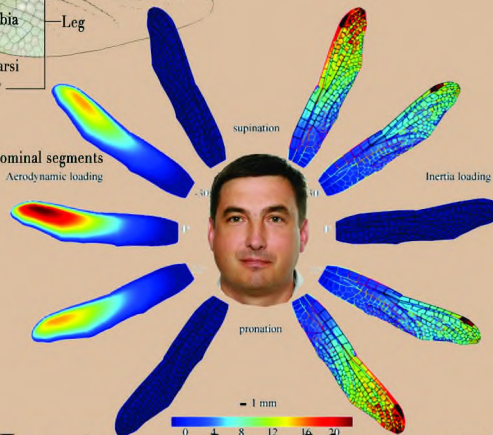
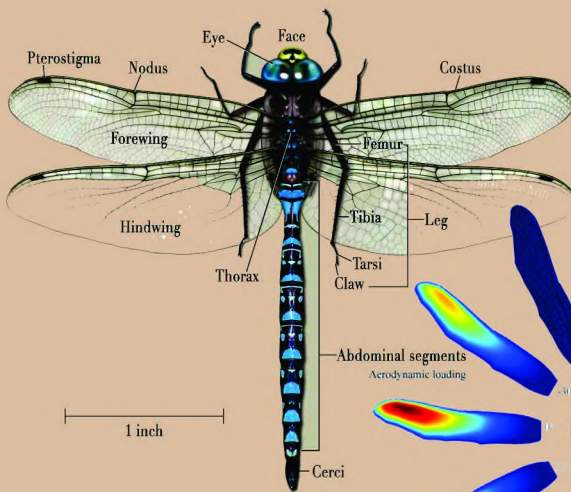
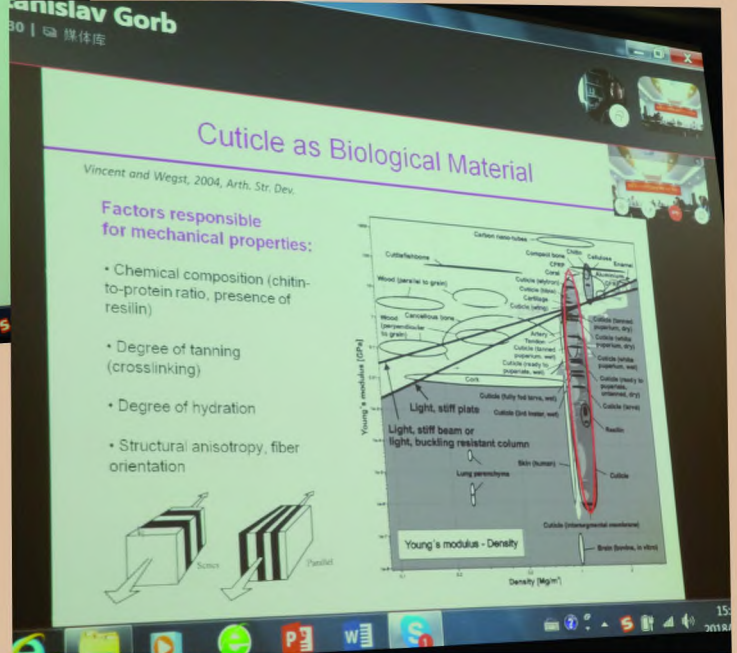

## How to use the achievements of nature in aviation structures?



# ASIAN WORKSHOP ON AIRCRAFT DESIGN EDUCATION 2018



Presentation from Russia,  
Kazan National Research  
Technical University – KAI:

Design and Manufacture Primary  
Load Carrying Parts of Aircraft  
from Composite Materials



# ASIAN WORKSHOP ON AIRCRAFT DESIGN EDUCATION 2018

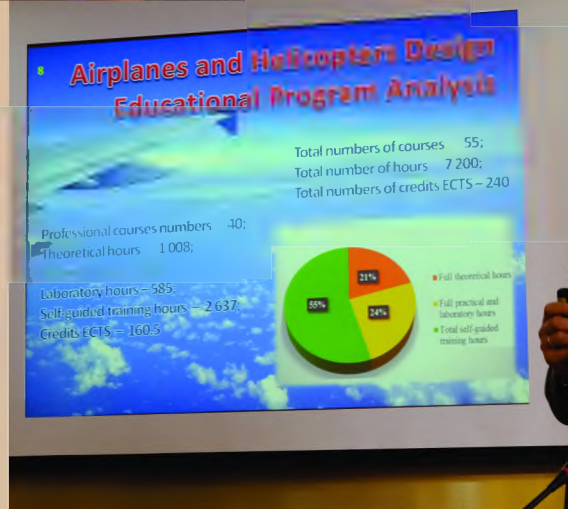

**Features of the Use Titanium Alloys in the Construction of Aerospace Setting**

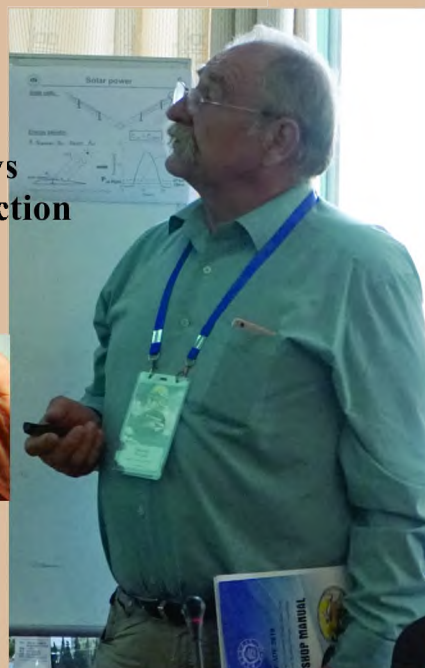

**Review of Problems of Ensuring Reliability of Fuel Systems of Modern Supersonic Business Jet Airplanes**

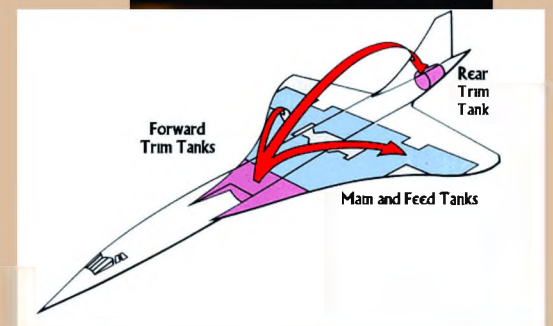
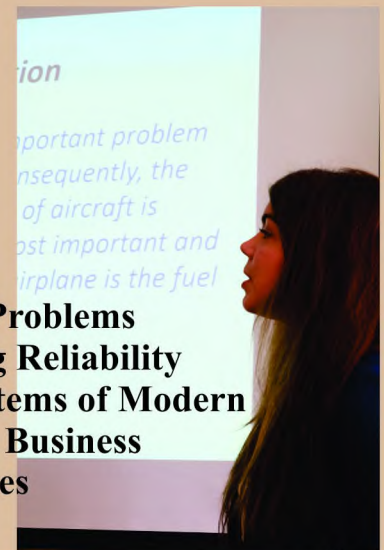

# ASIAN WORKSHOP ON AIRCRAFT DESIGN EDUCATION 2018

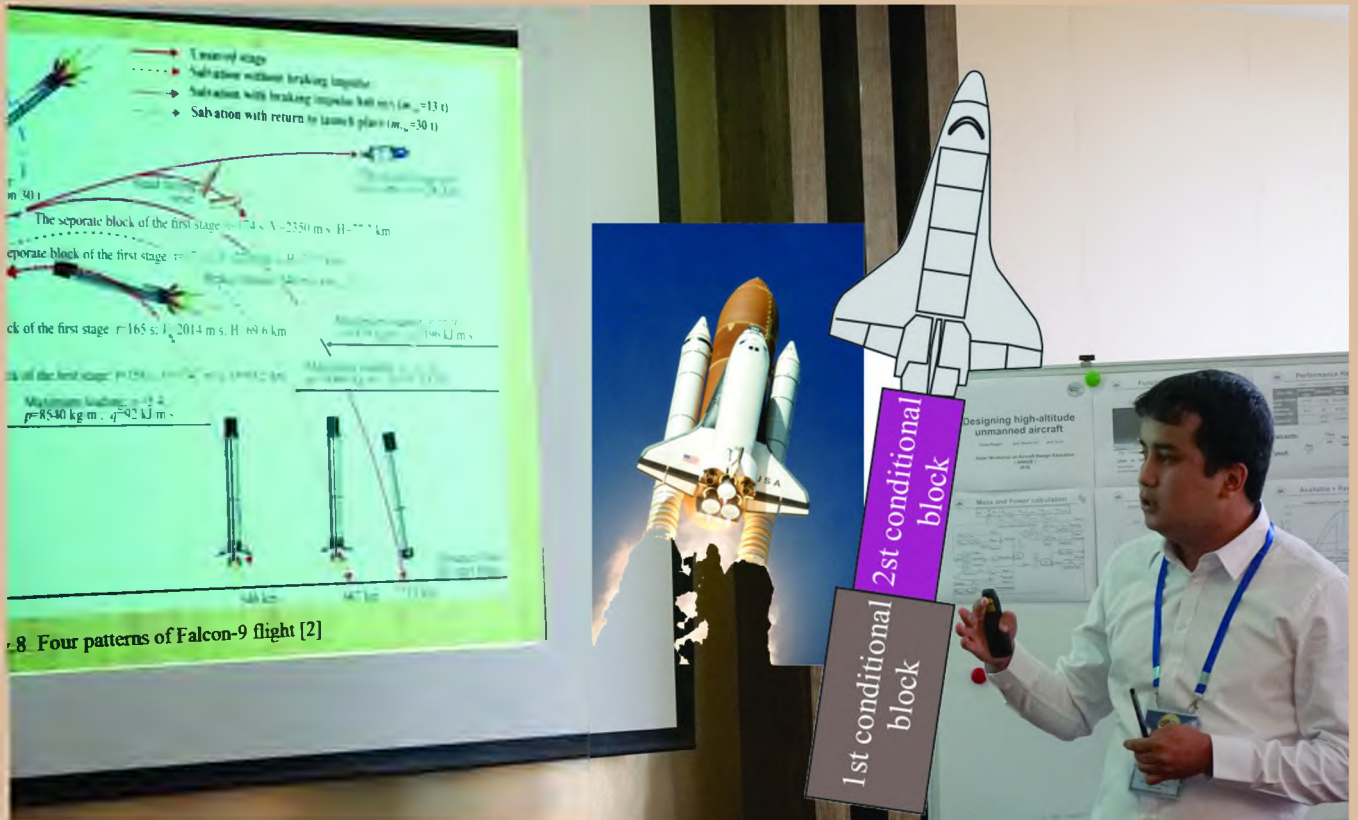

**What is the most effective way to return rocket stages for reuse?**





**Anthony P. Hays. Initial Aircraft Sizing – a Critique**

## Empty Weight Available

- Empty weight **available** as a function of assumed TOGW
- Calculated from mission analysis



## Model Airplane Flies Across Atlantic

- TAM 5
- August, 2003
- TOGW = 5 kg (11 lb)
- Dry weight = 2.7 kg (6 lb)
- EW fraction ~ 55%



Colored areas are excluded from wetted area

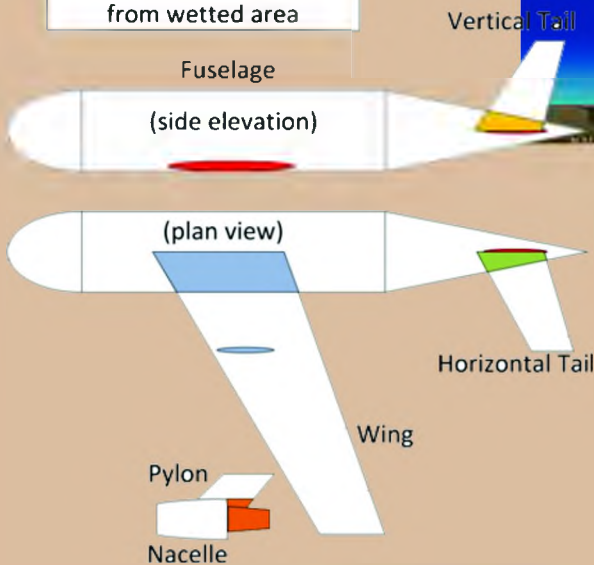

$$W_{empty} = W_{TO} - W_{fuel} - W_{payload} - W_{crew}$$







## PIEZOELECTRIC MOTOR FOR MICRO AIR VEHICLE

Piotr Vasiljev<sup>1,2</sup>, Dalius Mazeika<sup>1,3</sup>, Sergejus Borodinas<sup>1,3</sup>, Ying Yang<sup>1</sup>, Regimantas Bareikis<sup>2</sup>, Arunas Struckas<sup>2</sup>, Jianmin Qiu<sup>1</sup>

<sup>1</sup> Nanjing University of Aeronautics and Astronautics, Nanjing, China

<sup>2</sup> Lithuanian University of Educational Sciences, Vilnius, Lithuania

<sup>3</sup> Vilnius Gediminas Technical University, Vilnius, Lithuania

[Piotr.Vasiljev@leu.lt](mailto:Piotr.Vasiljev@leu.lt)

AWADE 2018, October 15 - 16, Nanjing, China

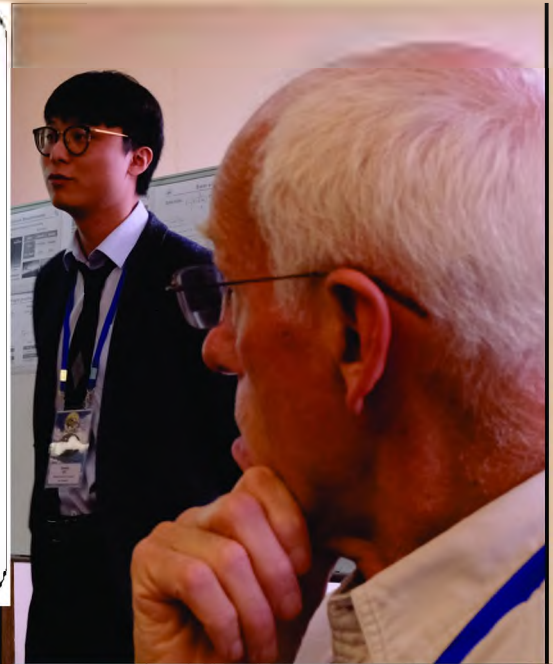

### NANO QUADCOPTER



Tiny quadcopter was introduced by ESTES company in 2013.

#### Dimensions and specification

- Size: length 6.4 cm, frame size 4.5 cm
- Weight: 11.3 g
- Motor type: DC
- Flight time: 10 min

### MILI HELICOPTER "Micro Elicottero"



### A MULTI-SPOKE ROTARY PIEZOELECTRIC MOTOR



Motor consist of trimorph disc, a shaft and two cone type alumina rotors. Operating principle is based on exciting the 1st radial mode of the disc. Spokes impact both rotors



### APPLICATION OF THE MOTOR

Single ultrasonic motor that can rotate two rotors can be successfully used for milli-size helicopter. It allows to reduce weight of the helicopter and to simplify design (no gear transmission is needed).



FEM model of the multimodal piezoelectric actuator

Application of the motor  
Milli-size helicopter with two propellers that are rotating in opposite directions. (Motor is located between propellers)

# ASIAN WORKSHOP ON AIRCRAFT DESIGN EDUCATION 2018

## Teaching of Russian Language in the Framework of Sandwich Project Between



Long-lasting friendly ties exist between National Aerospace University "KhAI" (Ukraine) and Nanjing University of Aeronautics and Astronautics



KhAI teachers are working on creating a textbook on the scientific style of speech for Chinese students who are trained within the framework of this sandwich project



# ASIAN WORKSHOP ON AIRCRAFT DESIGN EDUCATION 2018



And again on our Skype connection Australia



And again as exactly a year ago - Bucharest



And even distant Kenya with the head of Department of aerospace safety and logistics



AT THE HELM OF AERONAUTICS  
Diane Uyoga  
Moi University, Kenya  
Head of Department,  
Aerospace Security and Logistics



# ASIAN WORKSHOP ON AIRCRAFT DESIGN EDUCATION 2018

## Personal Student Design Competition

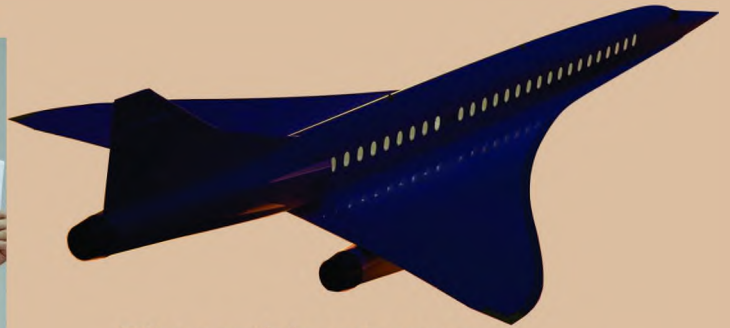

The participants were the students of three universities:

## Nanjing University of Aeronautics and Astronautics



## National Aerospace University KhAI Kharkiv (Ukraine)

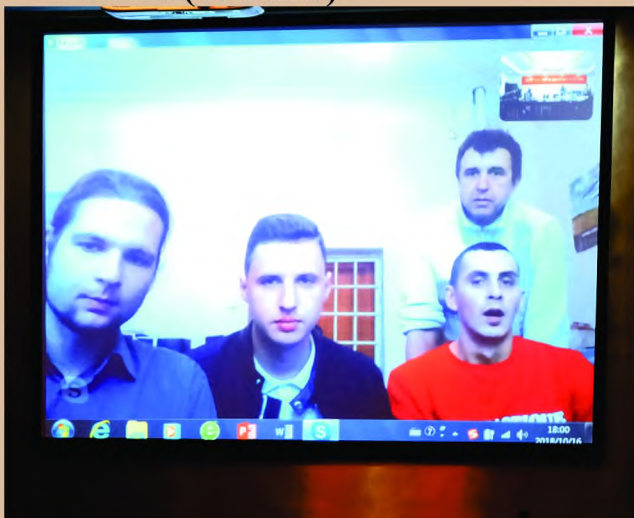

## Kazan National Research Technical University named after A. N. Tupolev (Russia)



# ASIAN WORKSHOP ON AIRCRAFT DESIGN EDUCATION 2018

## Discussion of results of the Personal Student Design Competition



### Strict jury



### And tired students



# ASIAN WORKSHOP ON AIRCRAFT DESIGN EDUCATION FOR THREE YEARS



2016

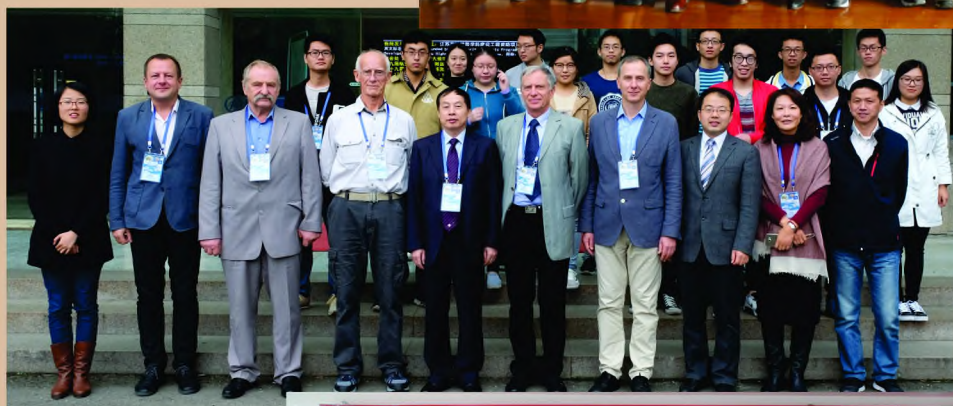

2017



2018



In the design of the Proceedings were used photos of Miao Liu and Anatolii Kretov